

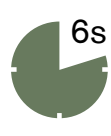

Installed quickly & easily, AusPress Stainless is installed without flame as the preferred method for installing grade 316 stainless pipework.



Press a 28mm fitting onto the stainless tube in under 6 seconds. Join done.

Faster to Install

AusPress press-fit offers large time savings compared to welding, threading, grooving or glueing.

Safer to Use

- We train your team on-site.
- One button tool operation.
- Lightweight battery tools.
- No flames or hot work permits.
- No heavy gas tanks.
- No hazardous fumes.
- Less risk.

Experience Counts

We were the first to supply press-fit stainless in Australia & New Zealand.

We work with consultants & installers on specialised complex projects regularly.

Quality to Install

Approved to WaterMark, ActivFire, Australian & International standards.

Material traced from coil to tube & fittings (3.1 certs).

Superior temperature tolerance.

Longitudinally **TIG welded** stainless tube 15 - 108mm.

Reliable Design

Suits a wide range of applications.

Permanent high strength with the original **'M' press** join profile.

Consistent low profile join look & quality each time.

Environmental Choice

Long service life.

Closed loop material (completely recycled to make more stainless).

Efficient and waste free install.

Installing AusPress®



OD 15 to 168mm

Start to install quicker...

AusPress press-fit is installed easily & quickly using a Press Tool to form a permanent 'M' profile pressed joint between tube and fitting.



Start here

Check for suitability...

Both the piping material (eg 316L stainless steel) and the elastomer (the rubber ring seal) must be checked if suitable.

Installation only by qualified and licensed plumber in accordance with AS3500.

This guide is for standard applications. For different or specialised applications please contact us first.

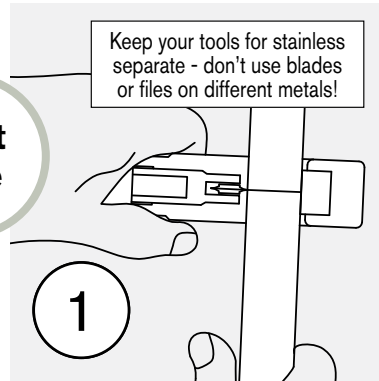

Cut to Length

Cut the tube square using a tube cutter with an 'inox' suitable blade.

For larger sizes, cut square with an 'inox' blade using a stainless rotary cutter or other suitable cold-cut tool.

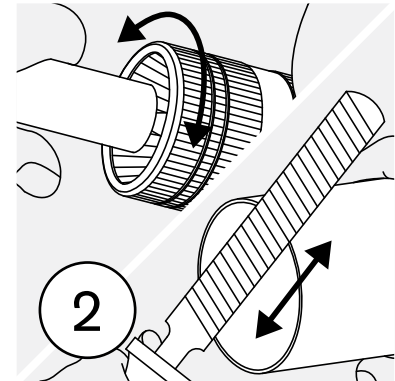

Deburr Tube

Deburr both inside & outside edges of tube ends to avoid cutting the ring seal on insertion.

For large sizes, use a half round smooth file reserved for stainless.

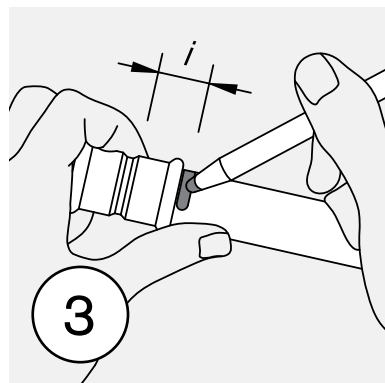

Mark the Insertion Depth "i"

Measure or use a depth gauge to mark the insertion depth (socket depth) onto the tube end.

This is a visual quality control mark to ensure the tube is fully inserted.

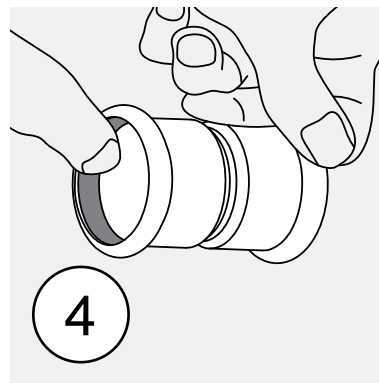

Inspect Fitting & Ring Seals

Check that the rubber ring seal is:

- The correct material type (colour) of seal is used.
- The seal is not damaged.
- Both fitting & seal are free of debris.

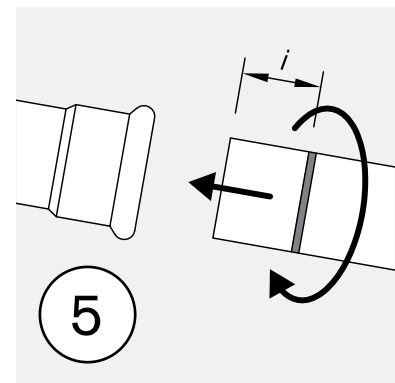

Join the Tube & Fitting

Insert the tube into the fitting press socket, turning slightly until it reaches the previously marked insertion depth.

Soapy water can be used if joining is difficult.

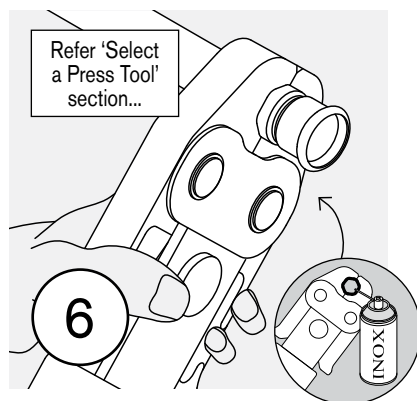

Press the Joint

Using a suitable press tool and M-profile jaw or collar, align the press jaw with the fitting and join following the tool manufacturer's instructions.

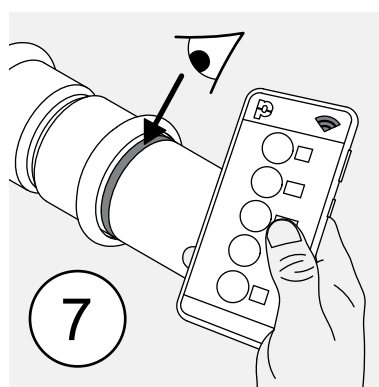

Check & Complete

Inspect the pressed fitting. Check insertion depth marking. Refer the NovoCheck app. Lubricate press zone of tool head as required.

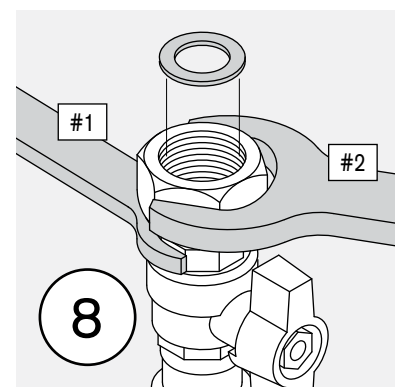

Threaded Ends

Tighten threads with the fitting supported, don't tighten against a pressed joint alone.



Select a Press Tool

The right tool for the job...

AusPress fittings are joined quickly & consistently using a press tool, fitted with an interchangeable M-Profile head matching the fitting diameter to form a permanent joint.

The chart below identifies the *maximum working pressure* based on the tube diameter and press tool & M-Profile head combination for potable water at 25°C using AusPress tube and fittings.

Confirm your project suitability before installing as some applications and specific fittings are limited to a lower pressure despite the system able to achieve higher; in these cases, the lesser pressure is used to rate the system capacity.

Refer to the technical section and contact us for more information.

Installation only by a qualified and licenced plumber to AS/NZS 3500.

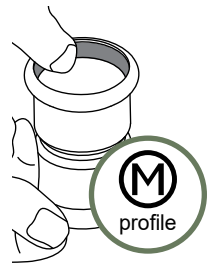

The 'M' Profile Press...

AusPress Stainless Metric fittings are manufactured with a M-Profile press socket.

The press tools, jaws and collars we supply are designed to suit M-Profile and although they may look similar to other types, the tolerances of others may be different. Using incorrect tooling may effect warranty as a result.

Tool Jaw & Collar Clearance?
See the technical section for dimensions to install press-fit clear of obstructions.

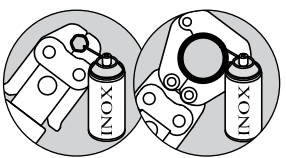
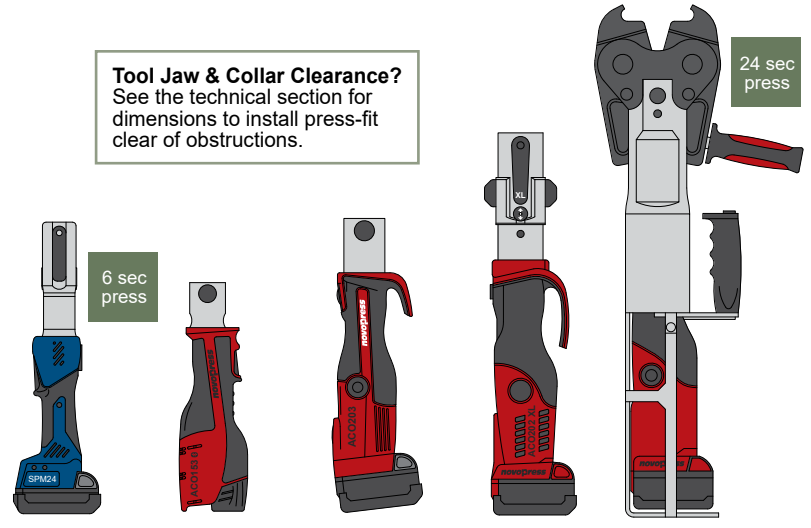

Ensure the inner press surfaces are lubricated with INOX for a smooth consistent press. Reapply as needed.

		SPM24 24kN	ACO153 24kN	ACO203 32kN	ACO203-XL 32kN	ACO403 120kN
	15 to 22mm	25 bar 362 psi 2,500 kPa	25 bar 362 psi 2,500 kPa	HP 60 bar 870 psi 6,000 kPa	HP 60 bar 870 psi 6,000 kPa	N/A
	28 to 35mm	25 bar 362 psi 2,500 kPa	25 bar 362 psi 2,500 kPa	25 bar 362 psi 2,500 kPa	25 bar 362 psi 2,500 kPa	N/A
'HP' Collar & ZB203 Adaptor		N/A	N/A	HP 60 bar 870 psi 6,000 kPa	HP 60 bar 870 psi 6,000 kPa	N/A
ZB203 Adaptor Jaw & 'M' Collar	42mm & 54mm	N/A	N/A	25 bar 362 psi 2,500 kPa	25 bar 362 psi 2,500 kPa	N/A
'HP' Collar & ZB203 Adaptor	66.7 mm	N/A	N/A	HP 40 bar 580 psi 4,000 kPa	HP 40 bar 580 psi 4,000 kPa	N/A
Ø66.7, 76.1, 88.9 use ZB221 adaptor. Ø108 use ZB221 & ZB222 adaptors.		N/A	N/A	N/A	N/A	25 bar 362 psi 2,500 kPa
'HP' Collar (for ACO403 only)	76.1 to 108mm	N/A	N/A	N/A	N/A	HP 25 bar 362 psi 2,500 kPa
Double Offset Press Collar (for ACO403 only)	139.7 mm	N/A	N/A	N/A	N/A	20 bar 290 psi 2,000 kPa
	168.3 mm	N/A	N/A	N/A	N/A	16 bar 232 psi 1,600 kPa

Please Note: This chart is only a guide. Values noted are *Maximum Working Pressure* of the press joint using the tool combinations shown; not the safety, or testing pressure, nor pressures for all applications. Some media are only suitable at lower pressures that shall be confirmed before installation to meet applicable safety and performance standards by the installer. Additional technical information, Tech Notes and advice is available from AusPress on request. Higher working pressures are on request with written approval from AusPress only.

AusPress Metric Stainless Range

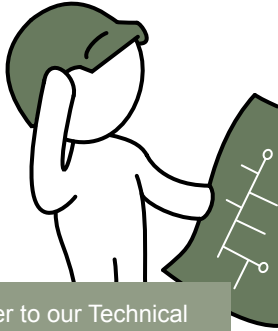

Refer to our Technical Data Sheets for material suitability and resistance.

What Stainless Grade should I use?

We stock grade 316 post-annealed stainless steel tube, in metric diameters to suit the AusPress press-fit range.

Fittings are supplied in 316L stainless steel and are compatible with either 304 or 316 metric tube to AS 5200.053 (EN 10312, series 2).

Please ask us if you require more information or technical advice for your project.

For technical information for specialised projects please ask us. With over 30 years of experience, have access to testing metallurgist services too.

Tube Bending:

Tube diameters up to 35mm can be cold bent with a commercial bender to a radius no less than 3.5x the tube diameter.

Eg: 15 (tube dia) x 3.5 = 52.5mm radius min along the centre line.

Stainless Tube 6m ANNEALED

Tube: Post-Annealed Grade 316L Metric Tube

The insertion depth "i" is the tube length fully inserted into the socket of the press fitting for full joint strength to be achieved.

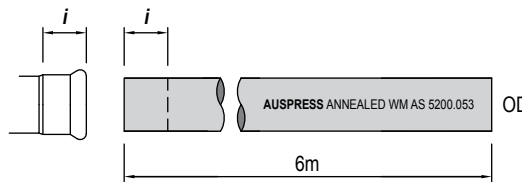

	Product No	OD (mm)	i depth	ID (mm)	Thk (t)	DN	Tube Weights (kg)		
							dry/m	dry/6m	wet/m
1/2"	316.96.015	15	22	13.0	1.0	15	0.4	2.1	0.5
3/4"	316.96.022	22	23	19.6	1.2	20	0.6	3.8	0.9
1"	316.96.028	28	26	25.6	1.2	25	0.8	4.9	1.3
1.1/4"	316.96.035	35	29	32.0	1.5	32	1.3	7.6	2.1
1.1/2"	316.96.042	42	32	39.0	1.5	40	1.5	9.2	2.7
2"	316.96.054	54	37	51.0	1.5	50	2.0	11.9	4.0
2.1/2"	316.96.066	66.7	51	62.7	2.0	65	3.3	19.5	6.3
3"	316.96.076	76.1	54	72.1	2.0	80	3.7	22.3	7.8
3.1/2"	316.96.088	88.9	61	84.9	2.0	90	4.4	26.3	10.0
4"	316.96.108	108	82	104.0	2.0	100	5.3	32.1	13.8
5"	316.96.139	139.7	98	135.7	2.0	125	6.9	41.5	21.4
6"	316.96.168	168.3	126	164.3	2.0	150	8.4	50.3	29.6

✓ **Grade 316 Stainless** has a greater resistance to chlorides than lesser grades such as 304 stainless.

✓ **Post-Annealed Tube** for additional resistance and performance especially for filtered and purified waters.

✓ **WaterMark Approved** tube to AS 5200.053 & EN 10312 (series 2) conformance and AS 4020 for contact with potable water.

✓ **TIG longitudinal welded**, rolled seam tube construction, with internal clean & cap process before leaving the factory.

✓ **3.1 Certified** with each length batch traceable back to the base material.

✓ **Factory Tested** each length with Eddy Current (ECT) and hydrostatic quality testing for before dispatch.

Installation Tools

Press Tools: Please refer to the Press Tool Range section for tool and press head capabilities and availability or contact AusPress directly.

Tube Deburrer
Inside and outside diameter cones, suits diameters 15 - 54mm.
Order: **VT.DEB**

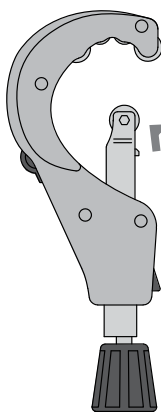
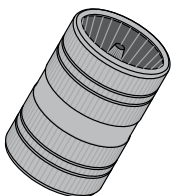

Manual Tube Cutter
Metal construction, Inox blade, suitable for diameters 6 - 76.1mm OD. Includes 1x spare cutting wheel in handle end.
Order: **VT.TCUT.006.076**

Replacement Inox Cutting Wheels
Includes wheel & bearing.
Order: **VT.TCUT.WHEEL**



Electric Tube/Pipe Cutter
240V 1200W electric pipe saw, portable and high-speed cutting of stainless pipes 54 - 220mm. Complete with carry bag, stainless inox blade and 4x pipe rollers.
Order: **ATC.EPC.220**

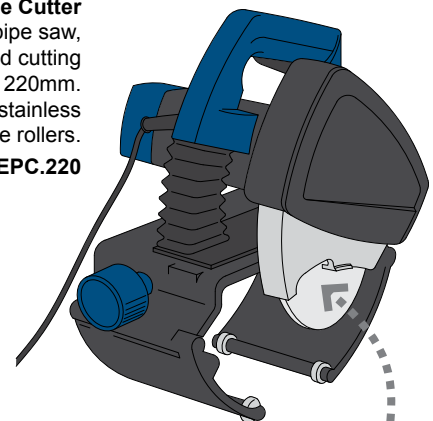

Replacement 140mm Blade
48 tooth inox blade, for cutting stainless, suits the ATC.EPC.220 tool.
Order: **ATC.EPC.BL**

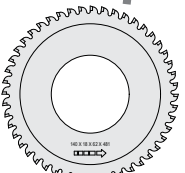



Rubber Ring Seals

Fittings are supplied with an EPDM type ring seal as standard in each press-socket.

Depending on the application, the ring seal may need to be changed to a different type, ie for higher chemical or temperature resistance.

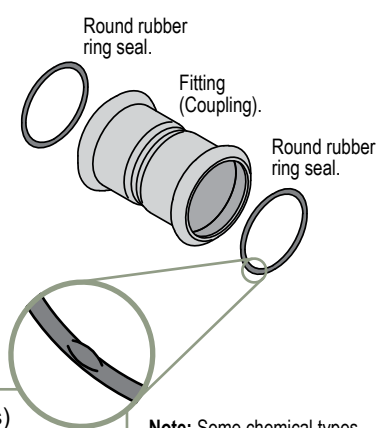

LBP (Leak Before Press)

features are small depressions that allow un-pressed fittings to drip leak during initial pressure testing to identify joins that require attention up to and including 54Ø.

EPDM Seal: Unpressed seal leaks when tested with water, pressures between 100 to 500kPa.

Note: Some chemical types and/or high concentrations can be unsuitable with stainless steel and ring seals.

Please contact us for suitability confirmation before installing, with a Project Info Sheet and any SDS details or laboratory water test results.

Coupling Socket - Socket

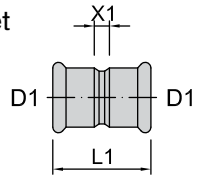

Material: 316L stainless steel.

Ring Seal: EPDM x2 supplied.

Product No	D1	L	X1
316.21.015	15	48	8
316.21.022	22	51	8
316.21.028	28	52	8
316.21.035	35	70	18
316.21.042	42	78	18
316.21.054	54	86	18
316.21.066	66.7	127	31
316.21.076	76.1	141	33
316.21.088	88.9	160	45
316.21.108	108	197	58
316.21.139	139.7		
316.21.168	168.3	300	64

Slip Coupling Socket - Socket

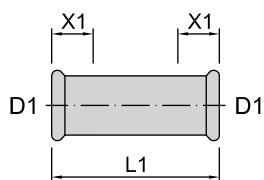
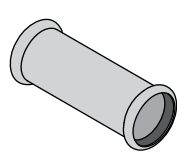

Material: 316L stainless steel.

Ring Seal: EPDM x2 supplied.

Product No	D1	L	X1 _{min}
316.22.015	15	65	28
316.22.022	22	74	20
316.22.028	28	83	22
316.22.035	35	100	26
316.22.042	42	115	30
316.22.054	54	140	34
316.22.066	66.7	194	48
316.22.076	76.1	226	54
316.22.088	88.9	255	58
316.22.108	108	300	72
316.22.139	139.7		
316.22.168	168.3		

Spigot Reducer Socket - Tube End

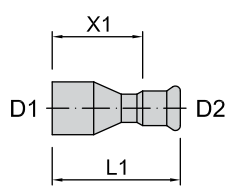
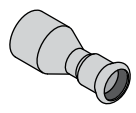

Material: 316L stainless steel.

Ring Seal: EPDM x1 (D2) supplied.

Product No	D1	D2	L	X1
316.23.022.015	22	15	64	44
316.23.028.022	28	22	65	46
316.23.035.015	35	15	77	57
316.23.035.022	35	22	81	62
316.23.035.028	35	28	74	52
316.23.042.015	42	15	85	65
316.23.042.022	42	22	86	67
316.23.042.028	42	28	82	60
316.23.042.035	42	35	88	62
316.23.054.015	54	15	92	72
316.23.054.022	54	22	92	73
316.23.054.028	54	28	93	71
316.23.054.035	54	35	101	75
316.23.054.042	54	42	101	71
316.23.066.042	66.7	42	131	
316.23.066.054	66.7	54	123	
316.23.076.042	76.1	42	132	102
316.23.076.054	76.1	54	132	98
316.23.076.066	76.1	66.7	142	
316.23.088.042	88.9	42	162	132
316.23.088.054	88.9	54	162	128
316.23.088.066	88.9	66.7	161	
316.23.088.076	88.9	76.1	179	126
316.23.108.054	108	54	179	145
316.23.108.066	108	66.7	176	
316.23.108.076	108	76.1	198	145
316.23.108.088	108	88.9	206	148
316.23.139.076	139.7	76.1		
316.23.139.088	139.7	88.9		
316.23.139.108	139.7	108		
316.23.168.088	168.3	88.9	379	321
316.23.168.108	168.3	108	360	289
316.23.168.139	168.3	139.7	307	209

Tee Equal Socket Ends & Branch

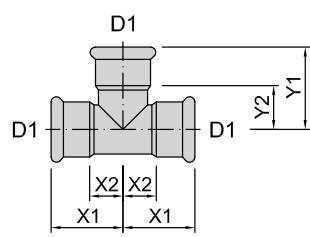
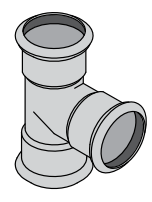

Material: 316L stainless steel.

Ring Seal: EPDM x3 supplied.

Product No	D1	X1	X2	Y1	Y2
316.51.015	15	32	12	39	19
316.51.022	22	36	16	42	21
316.51.028	28	41	19	47	25
316.51.035	35	50	24	53	27
316.51.042	42	57	27	60	30
316.51.054	54	68	34	71	37
316.51.066	66.7	97	49	99.5	51.5
316.51.076	76.1	113	59	110	55
316.51.088	88.9	128	72	128	69
316.51.108	108	150	81	154	85
316.51.139	139.7				
316.51.168	168.3	257	139	235	118

■ Tee Reduced Socket Ends & Branch

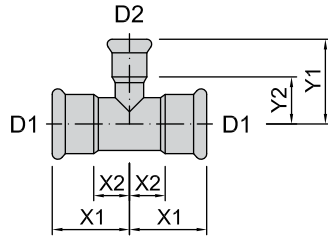
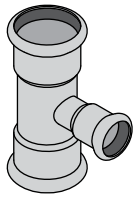

Material: 316L stainless steel.

Ring Seal: EPDM x3 supplied.

Product No	D1	D2	X1	X2	Y1	Y2
316.52.022.015	22	15	36	16	42	22
316.52.028.015	28	15	41	19	45	25
316.52.028.022	28	22	41	19	45	25
316.52.035.015	35	15	50	24	48	28
316.52.035.022	35	22	50	24	48	28
316.52.035.028	35	28	50	24	51	28
316.52.042.015	42	15	57	27	52	32
316.52.042.022	42	22	57	27	51	31
316.52.042.028	42	28	57	27	53	31
316.52.042.035	42	35	57	27	57	31
316.52.054.015	54	15	68	34	57	38
316.52.054.022	54	22	68	34	57	38
316.52.054.028	54	28	68	34	60	38
316.52.054.035	54	35	68	34	63	37
316.52.054.042	54	42	68	34	67	37
316.52.066.015	66.7	15	97	49	66.5	18.5
316.52.066.018	66.7	18	97	49	62.5	14.5
316.52.066.022	66.7	22	97	49	66.5	18.5
316.52.066.028	66.7	28	97	49	71.5	23.5
316.52.066.035	66.7	35	97	49	72.5	24.5
316.52.066.042	66.7	42	97	49	76.5	28.5
316.52.066.054	66.7	54	97	49	82.5	34.5
316.52.076.022	76.1	22	113	59	68	48
316.52.076.028	76.1	28	113	59	72	49
316.52.076.035	76.1	35	113	59	74	48
316.52.076.042	76.1	42	113	59	76	46
316.52.076.054	76.1	54	113	59	83	47
316.52.076.066	76.1	66.7	97			
316.52.088.022	88.9	22	128	72	75	55
316.52.088.028	88.9	28	128	72	79	56
316.52.088.035	88.9	35	128	72	81	55
316.52.088.042	88.9	42	128	72	83	53
316.52.088.054	88.9	54	128	72	90	54
316.52.088.076	88.9	76.1	128	72	115	63
316.52.108.022	108	22	150	81	84	64
316.52.108.028	108	28	150	81	88	65
316.52.108.035	108	35	150	81	90	64
316.52.108.042	108	42	150	81	95	65
316.52.108.054	108	54	150	81	99	65
316.52.108.076	108	76.1	150	81	127	73
316.52.108.088	108	88.9	150	81	136	74
316.52.139.054	139.7	54				
316.52.139.076	139.7	76.1				
316.52.139.088	139.7	88.9				
316.52.139.108	139.7	108				
316.52.168.054	168.3	54	257	139	140	105
316.52.168.076	168.3	76.1	257	139	157	103
316.52.168.088	168.3	88.9	257	139	167	110
316.52.168.108	168.3	108	257	139	182	111
316.52.168.139	168.3	139.7	230	104	220	122

■ MI Tee Socket Ends - MI BSP Branch

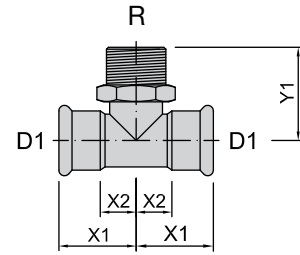
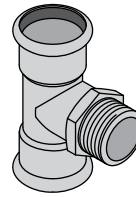

Material: 316L stainless steel.

Ring Seal: EPDM x2 supplied.

Product No	D1	R	X1	X2	Y1
316.54.015.015	15	1/2"	32	12	36
316.54.022.015	22	1/2"	37	16	41
316.54.022.020	22	3/4"	36	16	44
316.54.022.025	22	1"	42	19	49
316.54.028.015	28	1/2"	42	19	44
316.54.028.025	28	1"	41	19	50
316.54.035.020	35	3/4"	50	24	51
316.54.035.032	35	1.1/4"	50	24	57
316.54.042.040	42	1.1/2"	57	27	60
316.54.054.050	54	2"	69	34	75

■ FI Tee Socket Ends - FI BSP Branch

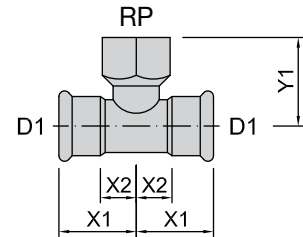
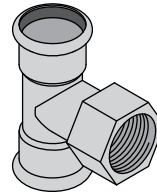

Material: 316L stainless steel.

Ring Seal: EPDM x2 supplied.

Product No	D1	RP	X1	X2	Y1
316.53.015.015	15	1/2"	32	12	36
316.53.022.015	22	1/2"	36	16	39
316.53.022.020	22	3/4"	36	16	44
316.53.028.015	28	1/2"	41	19	42
316.53.028.020	28	3/4"	41	19	46
316.53.028.025	28	1"	41	19	47
316.53.035.015	35	1/2"	50	24	45
316.53.035.020	35	3/4"	50	24	50
316.53.035.025	35	1"	50	24	52
316.53.035.032	35	1.1/4"	50	24	55
316.53.042.015	42	1/2"	57	27	48
316.53.042.020	42	3/4"	57	27	52
316.53.042.025	42	1"	57	27	55
316.53.042.040	42	1.1/2"	57	27	62
316.53.054.015	54	1/2"	68	34	55
316.53.054.020	54	3/4"	68	34	58
316.53.054.025	54	1"	68	34	60
316.53.054.050	54	2"	68	34	76
316.53.066.015	66.7	1/2"	97	49	64.5
316.53.076.020	76.1	3/4"	113	59	71
316.53.076.050	76.1	2"	113	59	91
316.53.088.020	88.9	3/4"	128	70	78
316.53.088.050	88.9	2"	128	70	97
316.53.108.020	108	3/4"	150	81	87
316.53.108.050	108	2"	150	81	107



90 Bend Socket - Socket

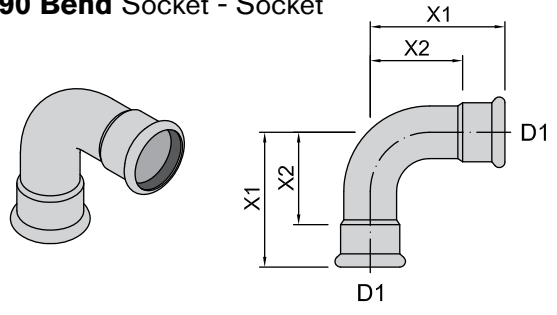

Material: 316L stainless steel. Ring Seal: EPDM x2 supplied.

Table with 4 columns: Product No, D1, X1, X2. Lists various product numbers and their dimensions.

45 Bend Socket - Socket

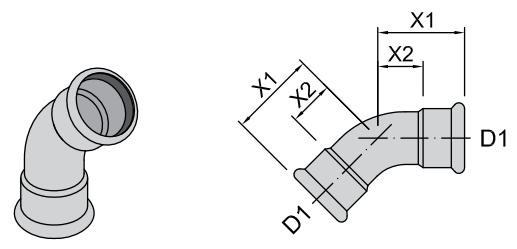

Material: 316L stainless steel. Ring Seal: EPDM x2 supplied.

Table with 4 columns: Product No, D1, X1, X2. Lists various product numbers and their dimensions.

90 Bend Socket - Tube End

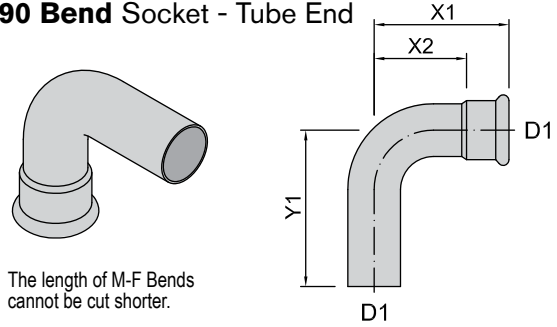

The length of M-F Bends cannot be cut shorter.

Material: 316L stainless steel. Ring Seal: EPDM x1 supplied.

Table with 5 columns: Product No, D1, X1, X2, Y1. Lists various product numbers and their dimensions.

45 Bend Socket - Tube End

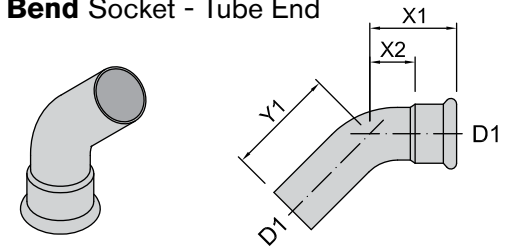

The length of M-F Bends cannot be cut shorter.

Material: 316L stainless steel. Ring Seal: EPDM x1 supplied.

Table with 5 columns: Product No, D1, X1, X2, Y1. Lists various product numbers and their dimensions.

90 Bend Tube End - Tube End

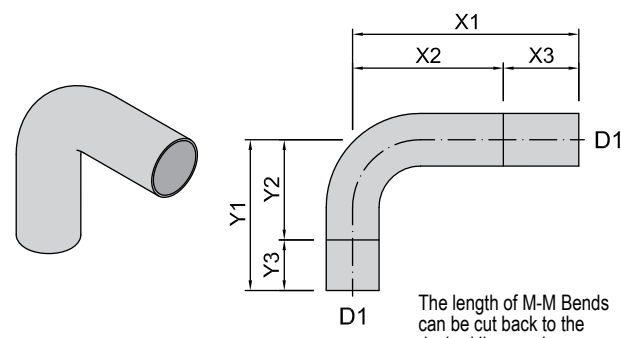

The length of M-M Bends can be cut back to the dashed line maximum.

Material: 316L stainless steel.

Table with 8 columns: Product No, D1, X1, X2, X3, Y1, Y2, Y3. Lists various product numbers and their dimensions.

Tube up to 35mm diameter can be bent using a commercial tube bender - refer to the technical section for more information.

■ **FI 90 Bend Socket - FI BSP**

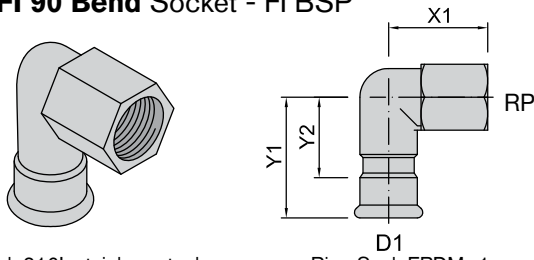

Material: 316L stainless steel. Ring Seal: EPDM x1 supplied.

Product No	D1	RP	X1	Y1	Y2
316.34.015.015	15	1/2"	37	57	37
316.34.022.015	22	1/2"	39	59	38
316.34.022.020	22	3/4"	46	59	39
316.34.028.020	28	3/4"	46	68	45
316.34.028.025	28	1"	54	67	44
316.34.035.032	35	1.1/4"	63	75	49
316.34.108.080	108	3"	106	186	104

■ **MI 90 Bend Socket - MI BSP**

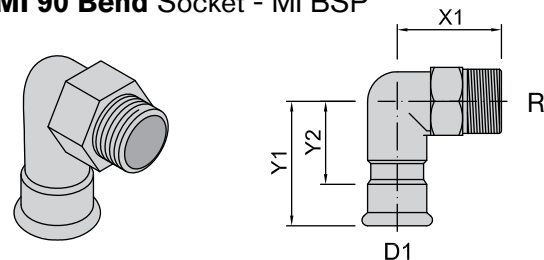

Material: 316L stainless steel. Ring Seal: EPDM x1 supplied.

Product No	D1	R	X1	Y1	Y2
316.35.015.015	15	1/2"	37	57	37
316.35.022.020	22	3/4"	46	59	39
316.35.028.025	28	1"	54	67	44
316.35.035.032	35	1.1/4"	63	75	49
316.35.042.040	42	1.1/2"	67	84	54
316.35.054.050	54	2"	78	93	60

■ **FI 90 Bend with Wall Plate Socket - FI BSP**

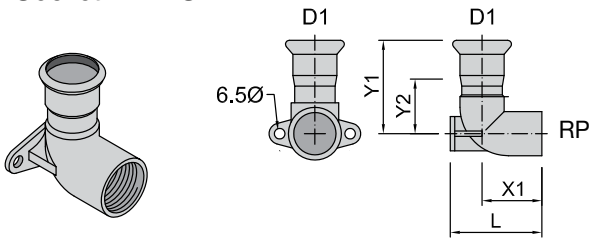

Material: 316L stainless steel. Ring Seal: EPDM x1 supplied.

Product No	D1	RP	L	X1	Y1	Y2
316.36.015.015	15	1/2"	44	30	50	28
316.36L.015.015	15	1/2"	65	30	50	30
316.36.022.015	22	1/2"	44	30	52	31
316.36.022.020	22	3/4"	51	34	55	33
316.36L.022.020	22	3/4"	65	34	55	34

= Longer mounting plate offset version.

■ **MI 90 Bend with Wall Plate Socket - MI (G) BSP**

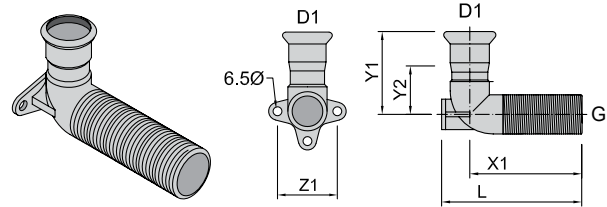

Material: 316L stainless steel. Ring Seal: EPDM x1 supplied.

Product No	D1	G	L	X1	Y1	Y2
316.37.015.015	15	1/2"	90	44	53	32
316.37.022.015	22	1/2"	90	44	60	34
316.37.022.020	22	3/4"	90	51	64	40

Fitting may not be suitable for flammable gasses - refer AS5601.1

■ **Type 58: Manifold-5 Socket - MI Branch**

Material: 316L stainless steel.

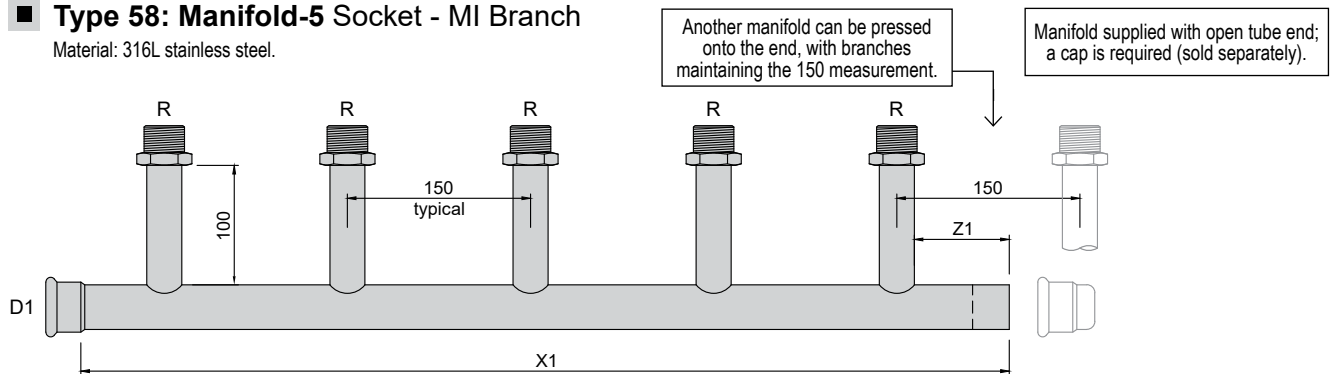

D1	R	X1	X2	Y1	Max Branch Load		Max Manifold Demand			
					EPDM	hNBR	Water (L/s)	Gas (MJ/h)	Water (L/s)	Gas (MJ/h)
28	1/2"	773	150	100	316.58.028.515	316G.58.028.515	0.30	120	< 0.50	< 220
28	3/4"	773	150	100	316.58.028.520	316G.58.028.520	0.30	120	< 0.50	< 220
35	1/2"	776	150	100	316.58.035.515	316G.58.035.515	0.35	210	< 0.85	< 380
35	3/4"	776	150	100	316.58.035.520	316G.58.035.520	0.35	210	< 0.85	< 380
42	1/2"	780	150	100	316.58.042.515	316G.58.042.515	0.60	250	< 1.35	< 630
42	3/4"	780	150	100	316.58.042.520	316G.58.042.520	0.60	250	< 1.35	< 630
54	1/2"	785	150	100	316.58.054.515	316G.58.054.515	0.80	350	< 2.40	< 1,250
108.6	3/4"	785	150	100	316.58.054.520	316G.58.054.520	0.80	350	< 2.40	< 1,250

Instantaneous Demand: Loads represent the total combined flow passing through the main manifold trunk at any one time to serve all active branches. Diversity Factors: Diversified peak values of actual appliances installed (as per AS/NZS 3500/5601 or equivalent) should be used to determine realistic instantaneous demand. Performance Limits: Sizing is based on maintaining a maximum pressure drop of 15 mbar (Water) or 0.05 kPa (Gas) and a velocity limit of 1.5 m/s (Water) or 5.0 m/s (Gas) to ensure silent and efficient operation. High-Pressure Gas: For 7.0 kPa or 35 kPa gas systems, higher MJ/h capacities may be achievable. Please contact our technical team for project-specific sizing.

Values to be used for general design work. All final manifold installations must be verified by a qualified professional and relevant codes, including AS/NZS 3500 & AS/NZS 5601.1.



■ **FI Adaptor Socket - FI BSP**

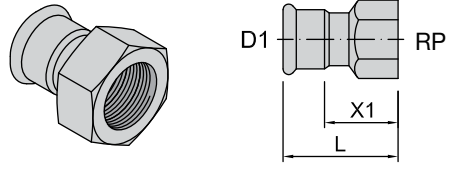

Material: 316L stainless steel. Ring Seal: EPDM x1 supplied.

Product No	D1	RP	L	X1
316.73.015.015	15	1/2"	54	34
316.73.015.020	15	3/4"	58	38
316.73.022.015	22	1/2"	52	32
316.73.022.020	22	3/4"	55	35
316.73.022.025	22	1"	58	38
316.73.028.020	28	3/4"	60	37
316.73.028.025	28	1"	60	37
316.73.028.032	28	1.1/4"	66	43
316.73.035.025	35	1"	64	38
316.73.035.032	35	1.1/4"	69	43
316.73.035.040	35	1.1/2"	73	47
316.73.042.032	42	1.1/4"	72	42
316.73.042.040	42	1.1/2"	77	47
316.73.054.040	54	1.1/2"	82	48
316.73.054.050	54	2"	90	56
316.73.066.065	66.7	2.1/2"	109	61
316.73.076.065	76.1	2.1/2"	117	38
316.73.088.080	88.9	3"	130	36
316.73.108.100	108	4"	156	41

■ **FI Adaptor Tube End - FI BSP**

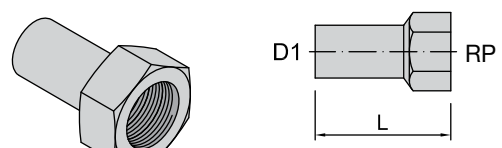

Material: 316L stainless steel. The length of this fitting cannot be cut shorter.

Product No	D1	RP	L
316.75.015.015	15	1/2"	58
316.75.022.015	22	1/2"	58
316.75.022.020	22	3/4"	62
316.75.028.020	28	3/4"	68
316.75.028.025	28	1"	69
316.75.035.032	35	1.1/4"	83
316.75.042.040	42	1.1/2"	94
316.75.054.050	54	2"	101

■ **Roll Groove Adaptor Socket - RG**

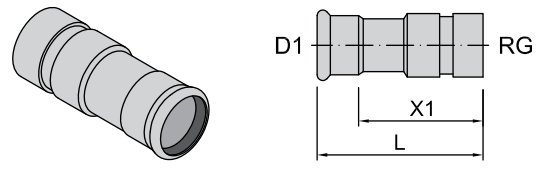

Material: 316L stainless steel. Ring Seal: EPDM x1 supplied.

Product No	D1	RG	L	X1
316.77.054.050	54	2"	82	45
316.77.066.065	66	2.5"	101	50
316.77.076.080	76	3"	103	49
316.77.088.080	88	3"	108	47
316.77.108.100	108	4"	123	41
316.77.139.100	139.7	5"	152	54
316.77.168.150	168.3	6"	175	49

■ **MI Adaptor Socket - MI BSP**

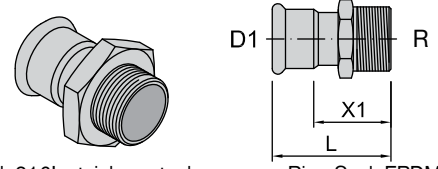

Material: 316L stainless steel. Ring Seal: EPDM x1 supplied.

Product No	D1	R	L	X1
316.74.015.015	15	1/2"	54	34
316.74.015.020	15	3/4"	58	38
316.74.022.015	22	1/2"	53	34
316.74.022.020	22	3/4"	57	38
316.74.022.025	22	1"	61	41
316.74.028.020	28	3/4"	60	38
316.74.028.025	28	1"	63	41
316.74.028.032	28	1.1/4"	67	45
316.74.035.025	35	1"	67	41
316.74.035.032	35	1.1/4"	71	45
316.74.035.040	35	1.1/2"	74	48
316.74.042.032	42	1.1/4"	75	45
316.74.042.040	42	1.1/2"	78	48
316.74.054.040	54	1.1/2"	82	48
316.74.054.050	54	2"	84	50
316.74.066.065	66.7	2.1/2"	112	64
316.74.076.065	76.1	2.1/2"	128	74
316.74.076.080	76.1	3"	142	86
316.74.088.080	88.9	3"	132	38
316.74.108.100	108	4"	157	42

■ **MI Adaptor Tube End - MI BSP**

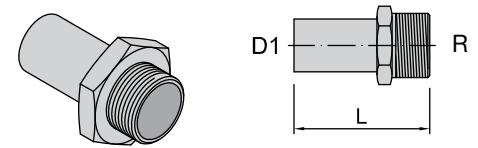

Material: 316L stainless steel. The length of this fitting cannot be cut shorter.

Product No	D1	R	L
316.76.015.015	15	1/2"	60
316.76.022.015	22	1/2"	55
316.76.022.020	22	3/4"	64
316.76.022.025	22	1"	62
316.76.028.025	28	1"	71
316.76.035.032	35	1.1/4"	81
316.76.042.040	42	1.1/2"	88
316.76.054.050	54	2"	93

■ **FI Adaptor Nut Socket - FI BSP**

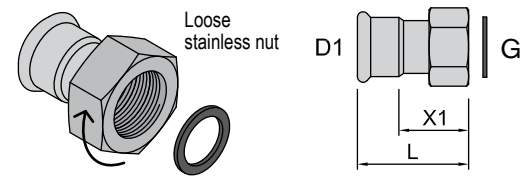

Material: 316L stainless steel. Ring Seal: EPDM x1 supplied.

Product No	D1	G	L	X1	Gasket
316.44.015.015	15	1/2"	50	30	A
316.44.015.020	15	3/4"	49	29	B
316.44.022.015	22	1/2"	58	37	A
316.44.022.020	22	3/4"	61	40	B
316.44.022.025	22	1"	54	33	C
316.44.028.025	28	1"	59	36	C
316.44.028.032	28	1.1/4"	61	38	D
316.44.035.040	35	1.1/2"	63	37	E
316.44.042.045	42	1.3/4"	68	38	F
316.44.042.050	42	2"			G
316.44.054.050	54	2"	94	59	G
316.44.054.065	54	2.1/2"	78	41	I

Note: FI (Rp) Adaptor Nut is not suitable for gas or steam applications!

■ Press Union Socket - Socket

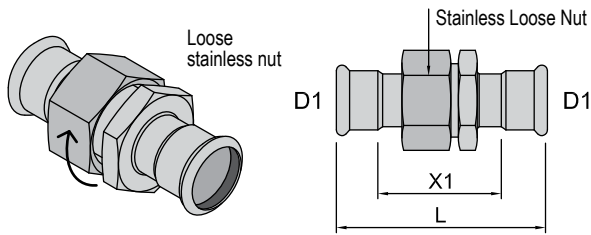

Material: 316L stainless steel.

Ring Seal: EPDM x2 supplied.
Gasket Seal: EPDM x1 supplied.

Product No	D1	L	X1	Gasket
316.83.015	15	89	49	A
316.83.022	22	99	57	C
316.83.028	28	112	66	D
316.83.035	35	115	67	E
316.83.042	42	128	68	F
316.83.054	54	141	71	H

When the Union (nut) is loosened or opened, the gasket is recommended to be replaced each time.

Note: Press Union is not suitable for gas or steam applications!

■ MI Union Socket - MI BSP

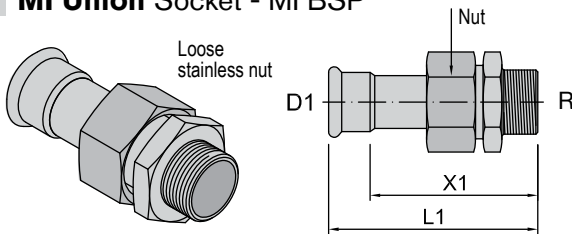

Material: 316L stainless steel.

Ring Seal: EPDM x1 supplied.
Gasket Seal: EPDM x1 supplied.

Product No	D1	R	L	X1	Gasket
316.82.015.015	15	1/2"	72	52	A
316.82.015.020	15	3/4"	75	55	B
316.82.022.015	22	1/2"	78	57	B
316.82.022.020	22	3/4"	79	78	C
316.82.022.025	22	1"	86	65	C
316.82.028.025	28	1"	91	69	D
316.82.035.032	35	1.1/4"	105	79	E
316.82.042.040	42	1.1/2"	113	83	F
316.82.054.050	54	2"	134	100	H

When the Union (nut) is loosened or opened, the gasket is recommended to be replaced each time.

Note: MI (R) Union is not suitable for gas or steam applications!

■ FI Union Socket - FI BSP

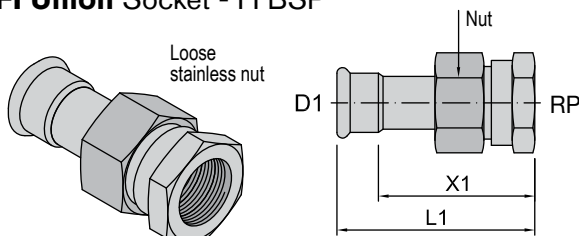

Material: 316L stainless steel.

Ring Seal: EPDM x1 supplied.
Gasket Seal: EPDM x1 supplied.

Product No	D1	RP	L	X1	Gasket
316.81.015.015	15	1/2"	67	47	A
316.81.015.020	15	3/4"	69	49	B
316.81.022.020	22	3/4"	74	54	C
316.81.022.025	22	1"	77	58	C
316.81.028.025	28	1"	85	63	D
316.81.035.032	35	1.1/4"	96	70	E
316.81.042.040	42	1.1/2"	105	95	F
316.81.054.050	54	2"	127	93	H

When the Union (nut) is loosened or opened, the gasket is recommended to be replaced each time.

Note: FI (Rp) Union is not suitable for gas or steam applications!

■ Stainless Steel Rubber Lined Brackets

Material: 316 stainless steel, mill finish. EPDM rubber lining.

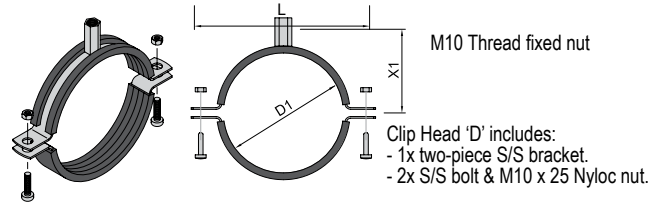

Product No	D1	X1	Thk	L
316.PC.015	15	27	1.5	70
316.PC.022	22	32	1.5	76
316.PC.028	28	34	1.5	85
316.PC.035	35	38	1.5	
316.PC.042	42	41	1.5	
316.PC.054	54	47	1.5	
316.PC.066	66	52	1.5	
316.PC.076	76	58	1.5	
316.PC.089	88	64	1.5	
316.PC.108	108	74	1.5	
316.PC.168	168	104	1.5	

■ Brackets Stainless Metric

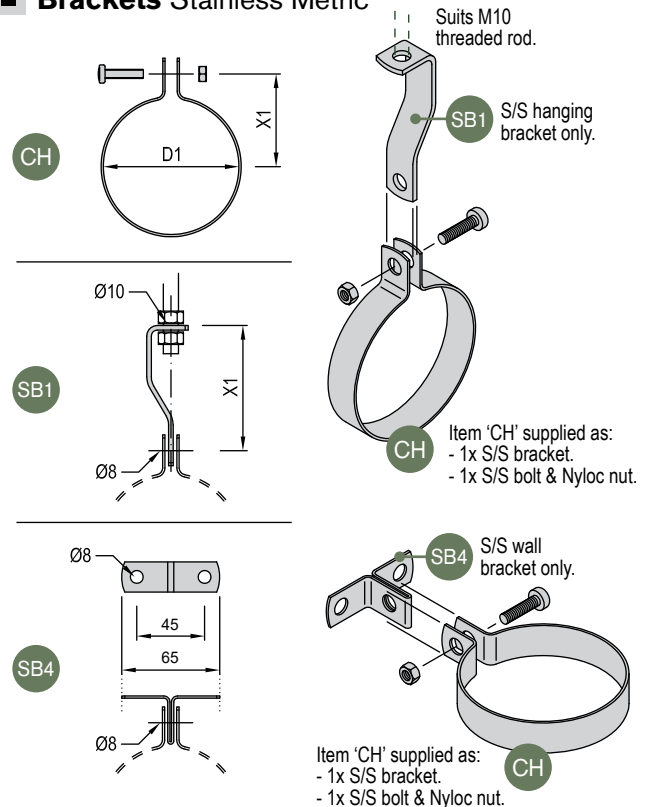

Material: 316 stainless steel.

Product No	D1	X1
316.SB1	-	80
316.SB4	-	14-22
316.CH.015	15	20
316.CH.022	22	24
316.CH.028	28	28
316.CH.035	35	32
316.CH.042	42	35
316.CH.054	54	40
316.CH.066	66	50
316.CH.076	76.1	50
316.CH.088	88.9	57
316.CH.108	108	70



■ Press Ball Valve 3-Piece

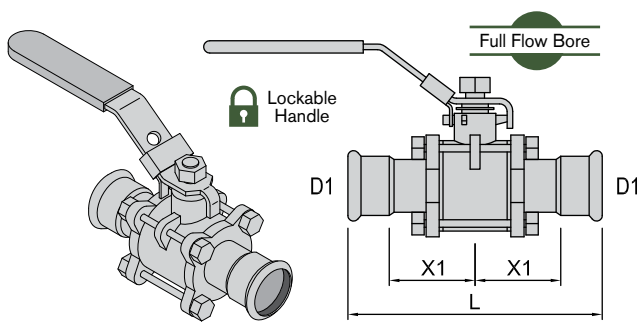

Press ends, Ball & Cast Body: 316 stainless steel.
Seat: PTFE, Handle Wrap: PVC. Ring Seal: EPDM x2 supplied.

Product No	D1	L	X1	AOP	MAOP
316.47.3PC.015	15	103	32	16 bar	19.2
316.47.3PC.022	22	118	38	16 bar	19.2
316.47.3PC.028	28	135	44	16 bar	19.2
316.47.3PC.035	35	150	49	16 bar	19.2
316.47.3PC.042	42	168	54	16 bar	19.2
316.47.3PC.054	54	200	65	16 bar	19.2
316.47.3PC.076	76.1	273	84	16 bar	19.2
316.47.3PC.088	88.9	312	96	16 bar	19.2
316.47.3PC.108	108	369	109	16 bar	19.2

*Check suitability of chemicals with us before ordering or installing.

■ Ball Valve 3-Piece FI BSP

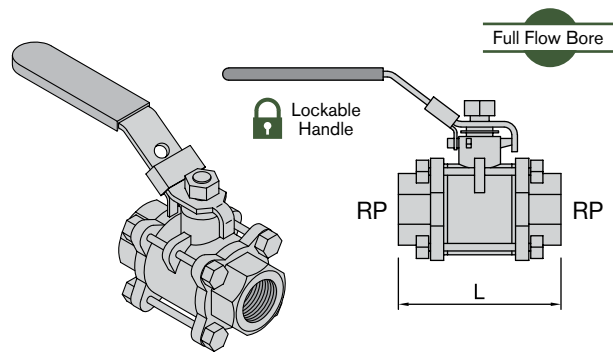

Body: CF8M stainless steel (cast version of 316).
Ball, Stem & Lever: 316 stainless steel. Working Temp: -20 to 180°C.
Seat: PTFE. Cold Max Water Working Pressure: 6,895kPa.

Product No	RP	L
316.BV3.015.WM	1/2"	64
316.BV3.020.WM	3/4"	71
316.BV3.025.WM	1"	81
316.BV3.032.WM	1.1/4"	94
316.BV3.040.WM	1.1/2"	104
316.BV3.050.WM	2"	127

*Check suitability of chemicals with us before ordering or installing.
Larger sizes are available on request.

■ Ball Valve 2-Piece FI BSP

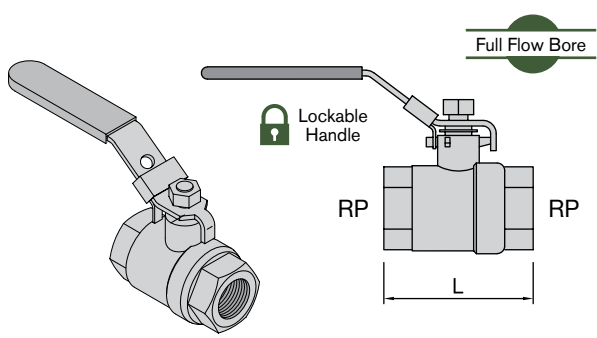

Body: CF8M stainless steel (cast version of 316).
Ball, Stem & Lever: 316 stainless steel. Working Temp: -20 to 180°C.
Seat: PTFE. Max Cold Water Working Pressure: 6,895kPa.

Product No	RP	L
316.BV2.015.WM	1/2"	58
316.BV2.020.WM	3/4"	66
316.BV2.025.WM	1"	77
316.BV2.032.WM	1.1/4"	90
316.BV2.040.WM	1.1/2"	98
316.BV2.050.WM	2"	121

*Check suitability of chemicals with us before ordering or installing.
Larger sizes are available on request.

■ Cover Flange (Escutcheon Plate)

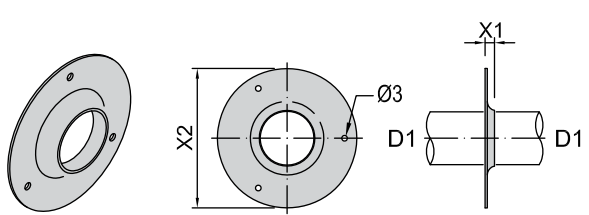

Material: 316L stainless steel. Finish: 2B surface.

Product No	D1	X1	X2
316.CF.015	15	5	40
316.CF.022	22	5	58
316.CF.028	28	5	74
316.CF.035	35	5	91
316.CF.042	42	5	110
316.CF.054	54	5	140

Note: The press socket end cannot pass through the cover flange opening, only the tube end.

End Cap Socket End

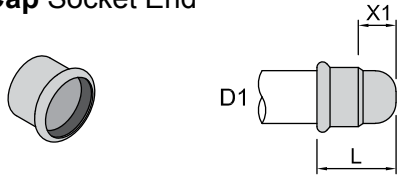

Material: 316L stainless steel.

Ring Seal: EPDM x1 supplied.

Product No	D1	L	X1
316.24.015	15	36	16
316.24.022	22	40	21
316.24.028	28	42	20
316.24.035	35	51	25
316.24.042	42	54	24
316.24.054	54	59	25
316.24.076	76.1	90	36
316.24.088	88.9	102	45
316.24.108	108	125	56

Bull Head Tee Socket x FI BSP Branches

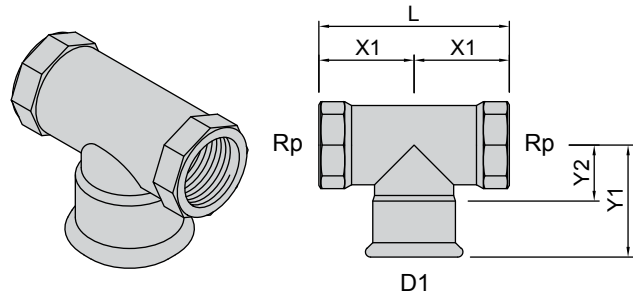

Material: 316L stainless steel.

Ring Seal: EPDM x1 supplied.

Product No	D1	Rp	L	X1	Y1	Y2
316.56.108.080	108	3"	260	130	153	72

Ring Seals & Union Gaskets

Ring Seals

Fittings with a press-fit socket are fitted with a EPDM rubber ring seal as standard.

Depending on the media, this ring seal should be changed to a different rubber material to suit the application.

Not sure? Refer to our Tech Note TN.03 Media Suitability Guide or contact us for confirmation of suitability.

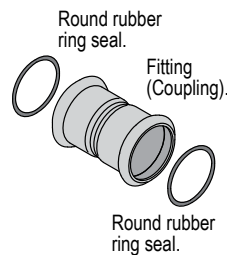

Union Gaskets

Union fittings are fitted with a (flat) rubber gasket seal and a (round) ring seal, both EPDM as standard.

Depending on the media, **both seals** should be changed to a different rubber material to suit the application.

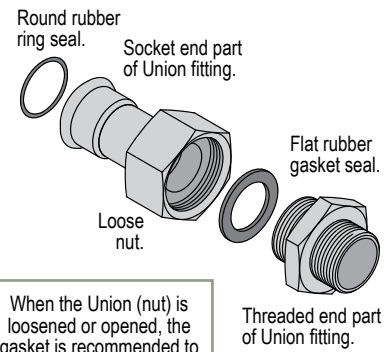

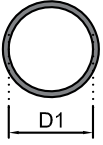
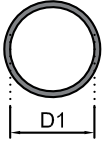
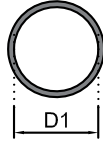
Rubber:	Pre-fitted in fitting standard	Optional extra	Optional extra
	EPDM	NBR	FKM
	Potable Water	Natural Gas	Oils & Fuel
			
Colour:	Black	Yellow	Green/Red
Temp:	-20°C to +110°C	-20°C to +70°C	-20°C to +180°C
D1	Product No	Product No	Product No
15	EPDM.11.015	NBR.11.015	FKM.11.015
22	EPDM.11.022	NBR.11.022	FKM.11.022
28	EPDM.11.028	NBR.11.028	FKM.11.028
35	EPDM.11.035	NBR.11.035	FKM.11.035
42	EPDM.11.042	NBR.11.042	FKM.11.042
54	EPDM.11.054	NBR.11.054	FKM.11.054
66.7	EPDM.11.066	NBR.11.066	FKM.11.066
76.1	EPDM.11.076	NBR.11.076	FKM.11.076
88.9	EPDM.11.088	NBR.11.088	FKM.11.088
108	EPDM.11.108	NBR.11.108	FKM.11.108
139.7	EPDM.11.139	NBR.11.139	FKM.11.139
168.3	EPDM.11.168	NBR.11.168	FKM.11.168

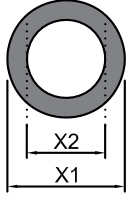
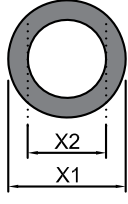
Rubber:	Pre-fitted in union fittings standard		Optional extra
	EPDM		FKM
	Potable Water		Oils & Fuel
			
Colour:	Black		Green
Temp:	-20°C to +110°C		-20°C to +180°C
D1	X1	X2	Product No
A	18	13	EPDM.12.015.015
B	24	15	EPDM.12.015.020
C	30	21.5	EPDM.12.022.020
D	38	27	EPDM.12.028.025
E	44.5	33.5	EPDM.12.035.032
F	50	41	EPDM.12.042.040
G	55	47	EPDM.12.042.050
H	65.5	53	EPDM.12.054.050
I	72	59	EPDM.12.054.065

Unions are not approved to be used for gas or steam applications!

Refer to the individual fitting listing for the compatible gasket letter.

Refer to our technical information for ring seal suitability and resistance.



Adaptor Flange Socket - Flange

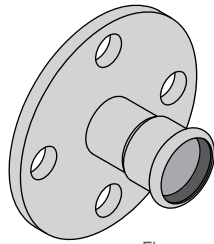

Flanges are welded internally & externally.

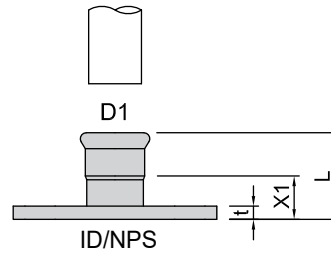
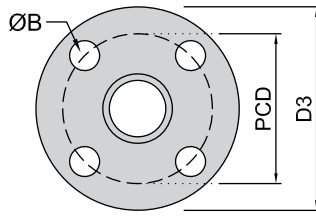

Dimension 't' includes any raised face height unless otherwise noted.

Blind (blank) Flange = 316.79...

Adaptor Flange (Tube End x Flange) = 316.72...

Bolts, nuts, washers and gaskets are not included.

ANSI-150 (B16.5)		Material: 316L stainless steel.				Ring Seal: EPDM x1 supplied.				
Product No	D1	FLANGE	NPS	D3	L [‡]	X1 [‡]	t min [‡]	PCD	ØB	Bolt (ØxL)
316.71.015A	15	ANSI 150	1/2"	89	35	15	11.3	60.3	16 x4	1/2x2"
316.71.022A	22	ANSI 150	3/4"	99	42	21	12.8	69.9	16 x4	1/2x2"
316.71.028A	28	ANSI 150	1"	108	52	29	14.3	79.4	16 x4	1/2x2.1/4"
316.71.035A	35	ANSI 150	1.1/4"	117	64	38	15.8	88.9	16 x4	1/2x2.1/4"
316.71.042A	42	ANSI 150	1.1/2"	127	75	45	17.3	98.4	16 x4	1/2x2.1/2"
316.71.054A	54	ANSI 150	2"	152	68	33	19.1	120.7	19 x4	5/8x2.3/4"
316.71.066A	66.7	ANSI 150	2.1/2"	178			22.2	139.7	19 x4	5/8x3"
316.71.076A	76.1	ANSI 150	3"	190	113	60	24.0	152.4	19 x4	5/8x3"
316.71.088A	88.9	ANSI 150	3"	190	127	67	24.0	152.4	19 x4	5/8x3"
316.71.108A	108	ANSI 150	4"	229	178	81	24.0	190.5	19 x8	5/8x3"
316.71.139A	139.7	ANSI 150	5"	254			24.0	215.9	23 x8	3/4x4"
316.71.168A	168.3	ANSI 150	6"	279	150	29	25.5	241.3	23 x8	3/4x4"

Install components in accordance with ASME B16.5. Bolts & nuts shall be fitted with flat washers of 304/316 stainless. ANSI flange dimensions 't', 'X1' & 'L1' include the raised face height of 1.6mm. Minimum machine bolt length shown, stud bolts will be longer.

Pressure Ratings:
Refer to Tech Note TN.25 for flange temperature, pressure and test pressure information.

AS 2129 (Tab-E)		Material: 316L stainless steel.				Ring Seal: EPDM x1 supplied.				
Product No	D1	FLANGE	ID	D3	L	X1	t	PCD	ØB	Bolt (ØxL)
316.71.015E	15	Tab-E.15	13.0	95	35	15	6	67	14 x4	M12x45
316.71.022E	22	Tab-E.20	19.6	100	42	21	6	73	14 x4	M12x45
316.71.028E	28	Tab-E.25	25.6	115	52	29	7	83	14 x4	M12x45
316.71.035E	35	Tab-E.32	32.0	120	64	38	8	87	14 x4	M12x50
316.71.042E	42	Tab-E.40	39.0	135	75	45	9	98	14 x4	M12x50
316.71.054E	54	Tab-E.50	51.0	150	68	33	10	114	18 x4	M16x60
316.71.066E	66.7	Tab-E.65	62.7	165	105	56	10	127	18 x4	M16x60
316.71.076E	76.1	Tab-E.80	72.0	185	113	60	11	146	18 x4	M16x60
316.71.088E	88.9	Tab-E.80	84.9	185	127	67	11	146	18 x4	M16x60
316.71.108E	108	Tab-E.100	104.0	215	165	81	13	178	18 x8	M16x65
316.71.139E	139.7	Tab-E.125	135.7	255	148		14	210	18 x8	M16x65
316.71.168E	168.3	Tab-E.150	164.3	280	163		17	235	22 x8	M20x70

Install components in accordance with AS 2129 (2000/2016). Bolts & nuts shall be fitted with flat washers of 304/316 stainless. Bolt dimensions, metric to imperial: M12 = 1/2"; M16 = 5/8", minimum machine bolt length shown, stud bolts will be longer.

Pressure Ratings:
Refer to Tech Note TN.25 for flange temperature, pressure and test pressure information.

EN 1092-1 (DIN)		Material: 316L stainless steel.				Ring Seal: EPDM x1 supplied.				
Product No	D1	FLANGE	ID	D3	L	X1	t	PCD	ØB	Bolt (ØxL)
316.71.015.PN16	15	PN16.15	13.0	95	46		14+2	65	14 x4	M12x45
316.71.022.PN16	22	PN16.20	19.6	105	52		16+2	75	14 x4	M12x50
316.71.028.PN16	28	PN16.25	25.6	115	57		16+2	85	14 x4	M12x50
316.71.035.PN16	35	PN16.32	32.0	140	57		18+2	100	18 x4	M16x55
316.71.042.PN16	42	PN16.40	39.0	150	67		18+3	110	18 x4	M16x55
316.71.054.PN16	54	PN16.50	51.0	165	74		20+3	125	18 x4	M16x55
316.71.066.PN16	66.7	PN16.65	62.7	185	88		20+3	145	18 x8	M16x55
316.71.076.PN16	76.1	PN16.80	72.0	200	116		20+3	160	18 x8	M16x60
316.71.088.PN16	88.9	PN16.80	84.9	200	134		20+3	160	18 x8	M16x60
316.71.108.PN16	108	PN16.100	104.0	220	149		22+3	180	18 x8	M16x60
316.71.139.PN16	139.7	PN16.125	135.7	250	176		22+3	210	18 x8	M16x60
316.71.168.PN16	168.3	PN16.150	164.3	285	171		24+3	240	22 x8	M20x70

Install components in accordance with EN 1092-1 (2018). Bolts & nuts shall be fitted with flat washers of 304/316 stainless. Overall flange thickness "t" shown as plate thickness + raised face height as separate values - add together for total flange thickness.

Pressure Ratings:
Refer to Tech Note TN.25 for flange temperature, pressure and test pressure information.

■ Axial Expansion Bellow Socket - Socket

Fitting: M-Profile, 316L stainless steel.
Ring Seal: EPDM x2 supplied fitted.

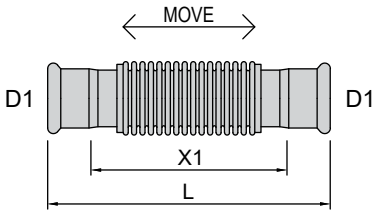
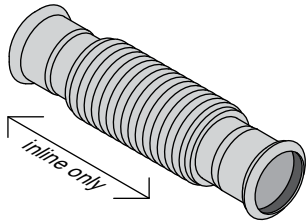

Product No	D1	L	X1	Move
316.28.015	15	139	99	-12/+6
316.28.022	22	139	97	-12/+6
316.28.028	28	150	104	-12/+6
316.28.035	35	177	125	-16/+8
316.28.042	42	202	142	-20/+10
316.28.054	54	222	152	-20/+10
316.28.066	66.7	285	183	-20/+10
316.28.076	76.1	352	246	-20/+10
316.28.088	88.9	388	272	-20/+10
316.28.108	108	446	308	-20/+10

Description: Designed to allow movement within straight pipe sections, this semi-flexible fitting is capable of adjusting in length in an axial plane to compensate for system movements associated with thermal expansion, low-level vibration, and/or seismic action.

Installation: Install above ground only. Install at the factory length to allow for plus and minus movement. Refer to Tech Notes TN.20 Brackets & Supports plus TN.27 Expansion & Contraction for bracketing and support requirements. Support is required both sides of this fitting to ensure movement remains axial.

Maintenance: Ensure corrugations remain clean and free of obstructions.

Max Working Pressure Ratings
Water: 1,600 kPa (16 bar) AS 3688.
Gas: 200 kPa (2 bar) AS 5201.

AusPress Electrical Conduit fittings are designed for use in electrical and data installations offering faster and more hygienic conduit installations in industrial applications. The AusPress Electrical Conduit fittings are designed for use in conjunction with AusPress standard tube and fittings in applications such as abattoirs, dairies, breweries, hospitals and various other applications requiring hygienic conduit systems.

**■ Electrical Conduit Adaptor
Socket - FI Metric**

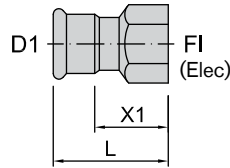
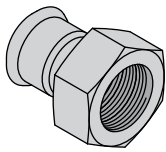

Material: 316L stainless steel.
Thread type: 1.5M

Ring Seal: EPDM x1 supplied.

Product No	D1	FI	L	X1
316.63.022.M20.15	22	20	58	37
316.63.028.M25.15	28	25	64	41
316.63.035.M32.15	35	32	64	38
316.63.042.M40.15	42	40	70	40
316.63.054.M50.15	54	50	76	41

Metric thread to ISO 724, ISO 261, AS1721 (metric thread) & ANSI/ASME B1.13M-1995 (not compatible with BSP).

**■ Electrical Conduit Adaptor
Socket - MI Metric**

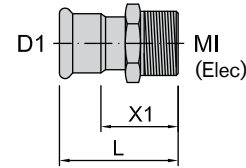
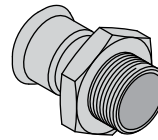

Material: 316L stainless steel.
Thread type: 1.5M

Ring Seal: EPDM x1 supplied.

Product No	D1	MI	L	X1
316.64.022.M20.15	22	20	55	34
316.64.028.M25.15	28	25	63	40
316.64.035.M32.15	35	32	67	41
316.64.042.M40.15	42	40	76	46
316.64.054.M50.15	54	50	88	53

Metric thread to ISO 724 & ANSI/ASME B1.13M-1995 (not compatible with BSP).





Tech Data Sheet: AusPress Stainless Press-Fit



M-Profile System



3.1 Cert Traceability



Diameters 15 to 168mm

What is Press-Fit?

A quick, flame free and consistent process using a press tool fitted with matching profiled jaw or collar to form a permanent and consistent join between tube and fitting.

Applications:

Common applications include:

- Potable, Chilled and Hot Water.
- Compressed Air.
- Fire Sprinklers & Services.
- Chemical lines.
- Fuels & Oils.
- Gases - Inert & Flammable.
- Steam (wet).
- Treated Water (including RO & demineralised).
- Vacuum.
- Not suitable for gravity sewer or stormwater.
- Other applications on request.

Refer to our Media Chart, tech data sheets, product catalogue or contact us directly for more information and suitability.

Key Features

- Very fast installation process.
- No need for hot-work permits.
- Simple process to train users to install using a press tool.
- One system suits a wide range of applications.
- Stocked in Australia.
- Tube & fittings grade 316L (1.4404) stainless steel.
- Large range of fitting types including flanged adaptors and threaded fittings.
- Long service life and recyclable product (closed reuse loop).
- Efficient and waste free install.

FAQ:

- Insulating? Specify 'low-chloride', refer our Tech Note TN.04.
- The tool head profile must match the fitting profile: ie M-on-M.
- Lubricate the press head 'press zones' regularly with Inox spray.
- Deburr the tube in & out to prevent damage to the ring seal.
- Using Steam, Oil, Fuel, Chlorine, Chlorides or going Underground? Refer our range of Tech Notes!
- Chemicals? Ask us to confirm suitability for stainless and ring seal.
- Pressure Test? Refer to our Test Protocol Form.
- Expansion? Calcs available.

Metric Tube

- Metric OD sizing, **15 to 168.3mm**.
- 316L **post-annealed** stainless steel.
- 320 grit finish (polished).
- **3.1 certified**; batch traceable.
- TIG welded (15 to 168.3mm) longitudinal welded, rolled seam, pre & post-annealed.
- ASTM 269 compliant tube.
- EN 10312 compliant tube.
- Markings – black.

Tube OD	Tube Wall	Weight (kg)	
		dry/m	wet/m
15	1.0	0.4	0.5
22	1.2	0.6	0.9
28	1.2	0.8	1.3
35	1.5	1.3	2.1
42	1.5	1.5	2.7
54	1.5	2.0	4.0
66.7	2.0	3.3	6.3
76.1	2.0	3.7	7.8
88.9	2.0	4.4	10.0
108	2.0	5.3	13.8
139.7	2.0	6.9	21.4
168.3	2.0	8.4	29.6

Press Fittings

- Metric OD sizing, **15 to 168.3mm**.
- **M-Profile** socket (with ring seal).
- Grade 316L (1.4404) **annealed** stainless steel.
- 320 grit finish (polished).
- **3.1 certified**; traceable batches.
- Ring seal pre-fitted to socket ends.
- Markings – laser etched.

Ring Seals (Elastomers)

- EPDM supplied standard.
- Contain no softening agents or other fillers which lead to embrittlement.
- Leak before press detection; identifies unpressed joints between 100-500kPa up to 54mm diameter.
- Slow aging process.
- Maintain a low compression set value, even at higher temps.
- Low oxygen permeation rate; this is critical in avoiding corrosion effects due to the intrusion of oxygen.

Seal Type*	Temp Range
EPDM	-20 to +100°C
hNBR	-20 to +70°C
FKM	-20 to +180°C

*Refer to our Media Chart & contact us for suitability before installation.

Pressure Ratings:

The maximum working pressure depends on the tool used to form the press, the operating temperature, fitting diameter and application parameters.

Maximum working pressures (kPa) for Potable Water at 25°C:		
Tube OD	Join Type	Working Pressure*
15	Standard	6,000
18 & 22	Standard	6,000
28 & 35	Standard	2,500
	HP	6,000
42 & 54	Standard	2,500
	HP	4,000
66.7	Standard	2,500
76.1 to 108	Standard	1,600
	HP	2,500
139.7	DbI Offset	2,000
168.3	DbI Offset	1,600

* Contact AusPress for advice if higher pressures and/or different applications.

System Approvals & Compliance:

- WaterMark
 - AS 5200.053
 - AS 3688
- CSIRO ActivFire
 - AS 4118.2.1
 - AS 2419.1
- DNV
 - Marine approved range "M"

Technical Assistance

- Suitability checks for projects & applications on request.
- Tech Notes and Media Chart product reference material.
- Onsite tool training of installers is recommended with certificates issued on completion.
- AusPress products stocked and available across Australia & New Zealand.

Need More Information?

Please contact us for product support, technical advice or your project specific requirements:

- Phone: 1300 287 773
- Email: sales@auspress.com.au

Visit auspress.com.au for the latest product information, tech notes & catalogues.