

Installed quickly & easily, the Floor Gully range has the advantage when hygiene, high temperatures and performance are critical.

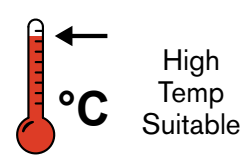

Hygienic Performance

Self-draining internal design to prevent stagnant water pooling. Concrete, tiled, epoxy and vinyl sheet floor type suitable. Epoxy edge lip infill for strength and hygiene. HACCP & EHEDG approved. Removable internal components for easier cleaning.

Quality to Install

Square, round and vinyl lock top designs available & stocked. Approved to WaterMark, Australian and international standards. Easy adjust support legs standard with stabilising feet. Designed specifically for hygiene and easy cleaning.

Experience Counts

We were the first to supply stainless drainage in Australia and New Zealand. We work with consultants and installers on specialised complex projects regularly. In-house design staff with local fabrication available for project requirements.

Reliable Design

With the strength and chemical resistance qualities of stainless steel. Range of grate options for pedestrian, forklift and truck load requirements.

Environmental Choice

Long service life. Closed loop material (completely recycled to make more stainless).

© AusPress Systems Pty Ltd. No part of this document may be copied, altered or extracted without our written consent. No responsibility is taken for any errors or omissions, contained or implied by this document. Information may be updated or corrected at anytime without notice.

Specification Guide

AusPress supply the Floor Gully range as individual components where depending on the application, the selected accessories are designed to fit within the drain bowl.

Accessories include the grate type, filter baskets, secondary strainers and a removable water trap (foul air trap).

These accessories are easily removed for cleaning individually and the drain bowl itself.

A summary is adjacent with specific details for all the drain bowl types on the following pages.



Follow the numbers to check if each is needed...

When ordering: Each accessory (including the drain bowl) has a separate product number.

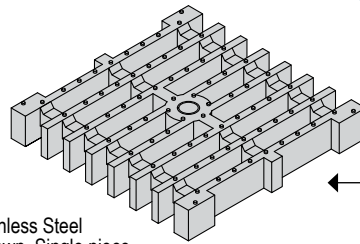

Cast Stainless Steel Grate shown. Single piece for strength and no places for bacteria to hide.

1 Grates

A range of grate types are stocked to suit various load, slip & flow ratings. Options listed page 9.

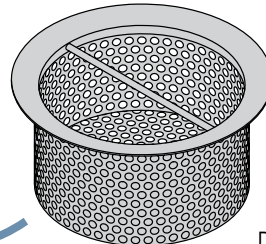

Standard height Basket (use in a standard height Drain Bowl with or without a FAT).

2 Filter Baskets

We stock standard height, extended height and silt baskets with 3mm mesh in accordance with local requirements.

Extended Height Filter Basket (use in standard height Drain Bowl without a FAT).

or

Dry Silt Trap Basket (use in standard height Drain Bowl without a FAT).

3 Foul Air Trap (FAT)

This optional accessory creates a water seal but unlike a P-Trap, this can be removed to access the pipework beyond for cleaning.

Use in a standard height Drain Bowl with a standard Filter Basket. Can be used with or without a P-Trap.

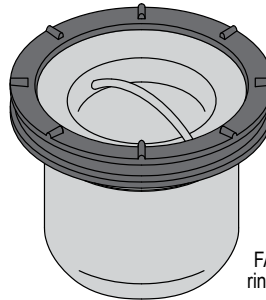

FAT with NBR seal ring - removable for easier cleaning.

4 Secondary Strainer

Security screw fixed in place above the outlet, this option is a requirement in most local authority approvals.

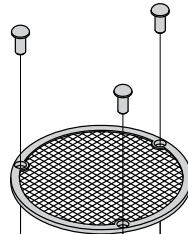

5 Drain Bowl

Hygienic smooth finish design with no laps, cavities or joins & stocked in 316 stainless steel standard.

The 110mm or 160mm spigot outlets connect to a range of drainage pipework including stainless drainage, HDPE and KG2000 PP drainage.

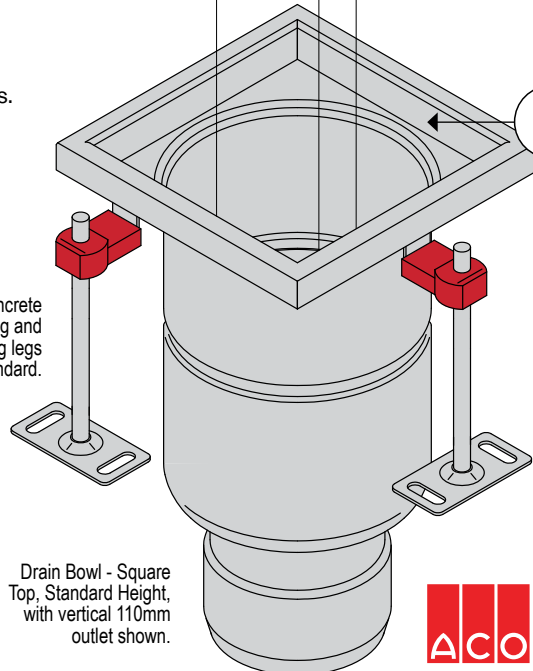

Concrete levelling and fixing legs standard.

Drain Bowl - Square Top, Standard Height, with vertical 110mm outlet shown.



This guide is only for standard applications.

For specific or specialised applications please contact us first - www.auspress.com.au

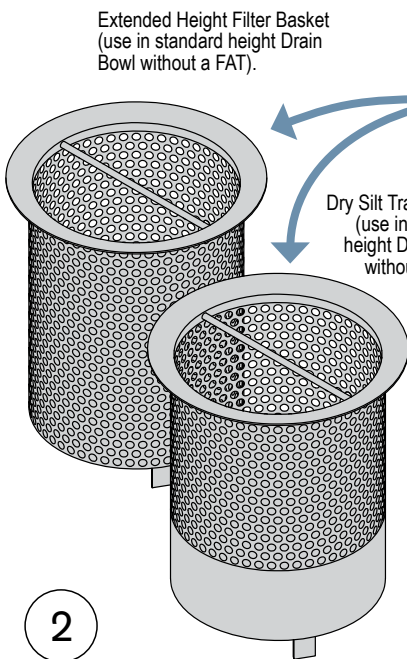

2

Extended Height Baskets

We stock Filter Baskets and Silt Trap Baskets in 'extended' versions for greater capacity, occupying the full height of standard height Drain Bowls.



Need WaterMark or Supermarket Approved Spec?

We can help spec with options for leading national supermarkets.

Items with WaterMark approval are notated with a WM in this section.



200 Drain Bowl 200 Square, Standard Height, 110-V Outlet

Material: 316L stainless steel body, epoxy infill hygienic & strong top edge.
Top: Square top for concrete, tiled or epoxy floor finishes.

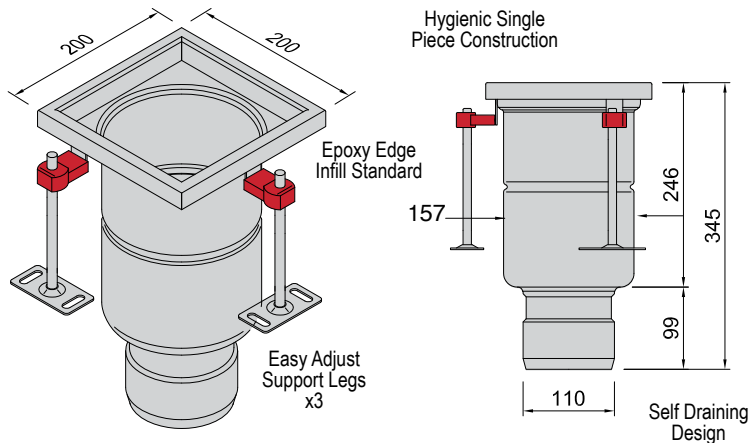

Ref	Item	Product No	Notes
G	Grate	See 'G2.SQ' grate options page AD37.	
FB	Filter Basket (Standard)	AD.FB2.075.03	3mm aperture
FBX	Filter Basket (Extended)	AD.FB2.200.03	3mm aperture
SB	Silt Basket (Solid Bottom)	AD.SB2.200.03	3mm aperture
FAT	Removable Foul Air Trap (FAT)	AD.FAT2.KIT	Flow Rate*: 3.5 L/sec
SS	Secondary Strainer Kit	AD.SSK.110.03	3mm aperture
DB	Drain Bowl	AD.DB2.SQS.110V	
PT	P-Trap	AP.PT.110	Flow Rate*: 3.4-10.4 L/sec

* Max rate based on a continuous flow of water in clean conditions. Accessories may reduce flow further.

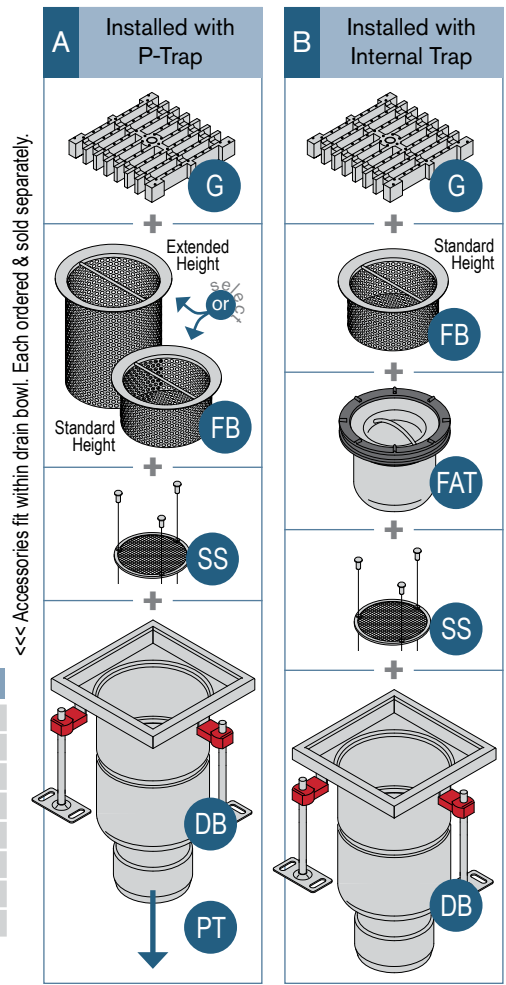

200 Drain Bowl 200 Square, Low Height, 110-V Outlet

Material: 316L stainless steel body, epoxy infill hygienic & strong top edge.
Top: Square top for concrete, tiled or epoxy floor finishes.

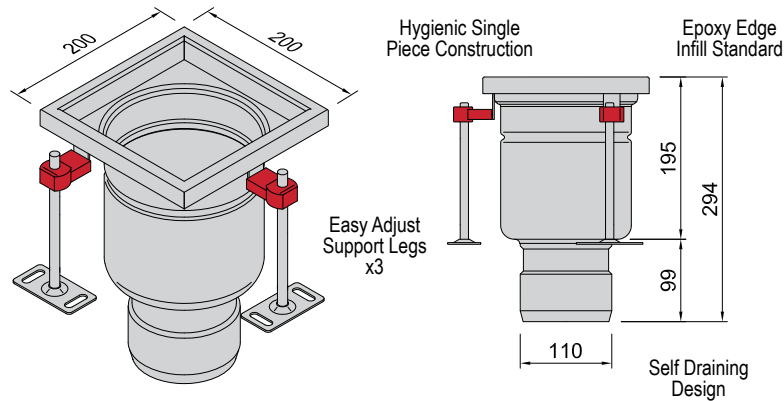

Note: A 'FAT' cannot be used with this drain.

Ref	Item	Product No	Notes
G	Grate	See 'G2.SQ' grate options page AD37.	
FB	Filter Basket (Standard)	AD.FB2.075.03	3mm aperture
SS	Secondary Strainer Kit	AD.SSK.110.03	3mm aperture
DB	Drain Bowl	AD.DB2.SQL.110V	
PT	P-Trap	AP.PT.110	Flow Rate*: 3.4-10.4 L/sec

* Max rate based on a continuous flow of water in clean conditions. Accessories may reduce flow further.

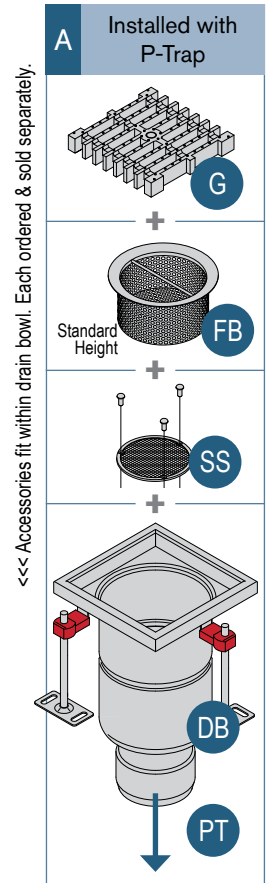

200

Drain Bowl 200 Square, Standard Height, 110-H Outlet

Material: 316L stainless steel body, epoxy infill hygienic & strong top edge.
Top: Square top for concrete, tiled or epoxy floor finishes.

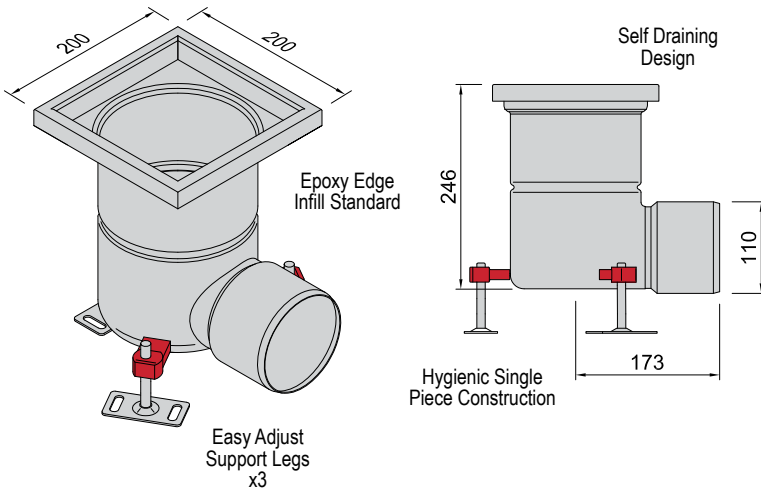

Note: Both a Filter Basket and a 'FAT' must be used with this drain.

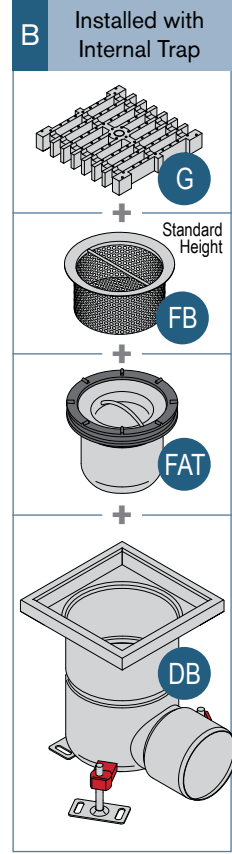

Ref	Item	Product No	Notes
G	Grate	See 'G2.SQ' grate options page AD37.	
FB	Filter Basket (Standard)	AD.FB2.075.03	3mm aperture
FAT	Removable Foul Air Trap (FAT)	AD.FAT2.KIT	Flow Rate [‡] : 3.5 L/sec
DB	Drain Bowl	AD.DB2.SQS.110H	

[‡] Max rate based on a continuous flow of water in clean conditions. Accessories may reduce flow further.

200

Drain Bowl 200 Vinyl, Standard Height, 110-V Outlet

Material: 316L stainless steel body, Vinyl lock ring top.
Top: Round vinyl lock top sheet floor finishes 1.5 - 3mm thick.

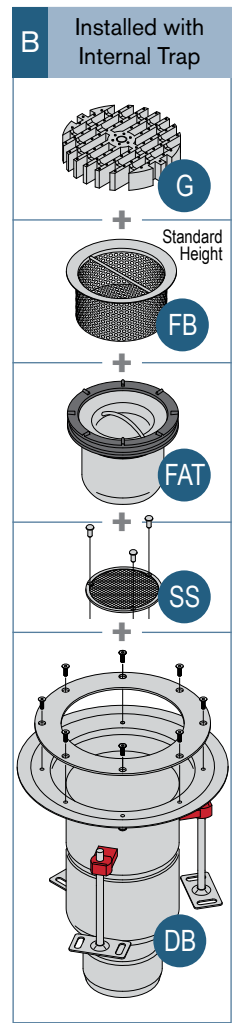
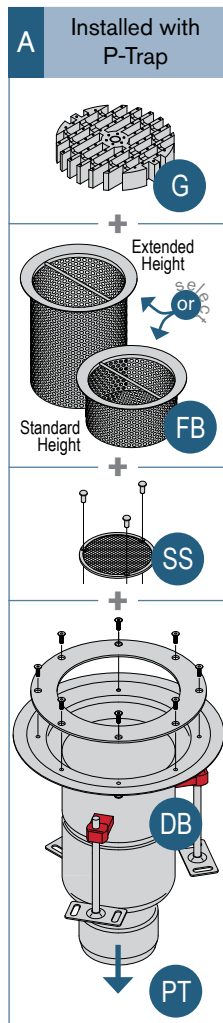
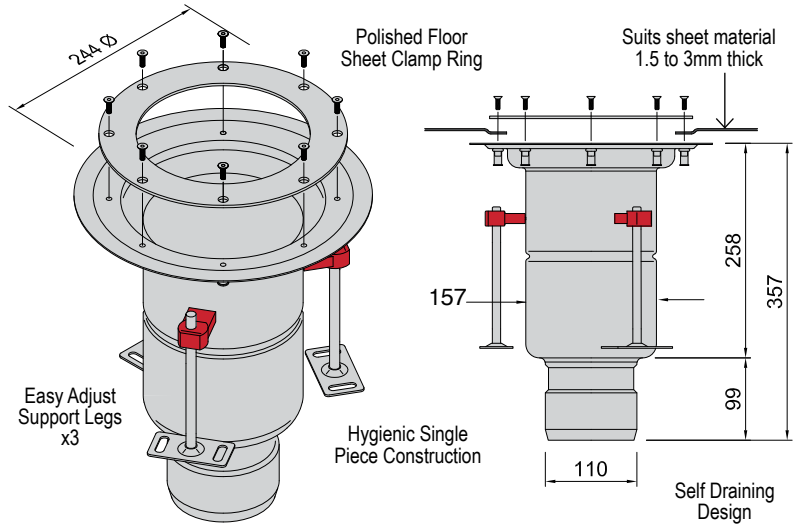

Ref	Item	Product No	Notes
G	Grate	See 'G2.RD' grate options page AD37.	
FB	Filter Basket (Standard)	AD.FB2.075.03	3mm aperture
FBX	Filter Basket (Extended)	AD.FB2.200.03	3mm aperture
SB	Silt Basket (Solid Bottom)	AD.SB2.200.03	3mm aperture
FAT	Removable Foul Air Trap (FAT)	AD.FAT2.KIT	Flow Rate [‡] : 3.5 L/sec
SS	Secondary Strainer Kit	AD.SSK.110.03	3mm aperture
DB	Drain Bowl	AD.DB2.VLS.110V	
PT	P-Trap	AP.PT.110	Flow Rate [‡] : 3.4-10.4 L/sec

[‡] Max rate based on a continuous flow of water in clean conditions. Accessories may reduce flow further.



300

Drain Bowl 300 Square, Standard Height, 110-V Outlet

Material: 316L stainless steel body, epoxy infill hygienic & strong top edge.
Top: Square top for concrete, tiled or epoxy floor finishes.

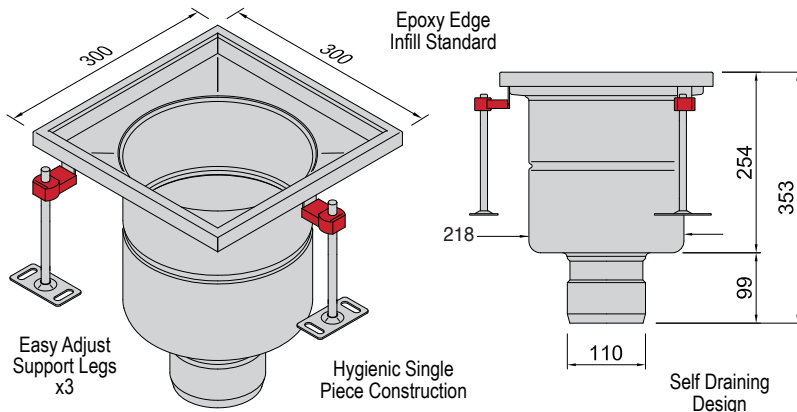

Ref	Item	Product No	Notes
G	Grate	See 'G3.SQ' grate options page AD37.	
FB	Filter Basket (Standard)	AD.FB3.075.03	3mm aperture
FBX	Filter Basket (Extended)	AD.FB3.200.03	3mm aperture
SB	Silt Basket (Solid Bottom)	AD.SB3.200.03	3mm aperture
FAT	Removable Foul Air Trap (FAT)	AD.FAT3.KIT	Flow Rate*: 4.6 L/sec
SS	Secondary Strainer Kit	AD.SSK.110.03	3mm aperture
DB	Drain Bowl	AD.DB3.SQS.110V	
PT	P-Trap	AP.PT.110	Flow Rate*: 3.4-10.4 L/sec

* Max rate based on a continuous flow of water in clean conditions. Accessories may reduce flow further.

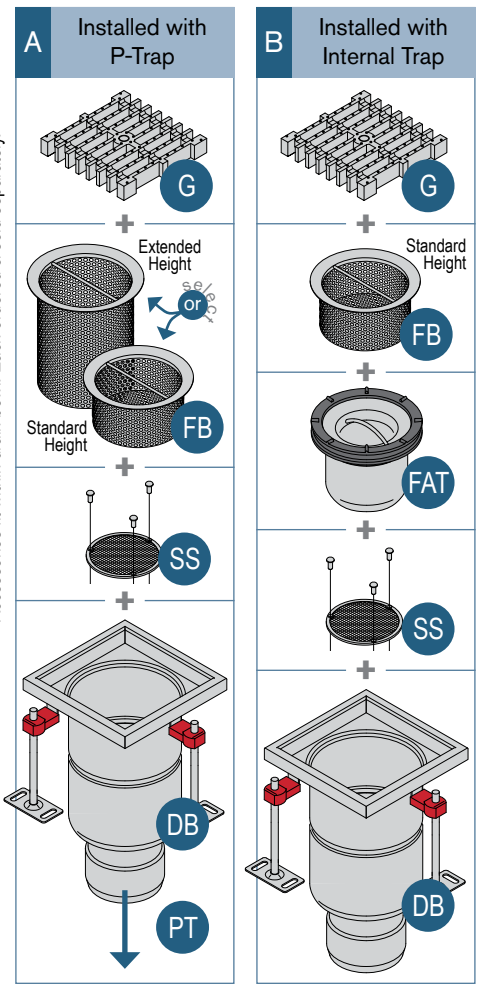

<<< Accessories fit within drain bowl. Each ordered & sold separately.

300

Drain Bowl 300 Square, Standard Height, 160-V Outlet

Material: 316L stainless steel body, epoxy infill hygienic & strong top edge.
Top: Square top for concrete, tiled or epoxy floor finishes.

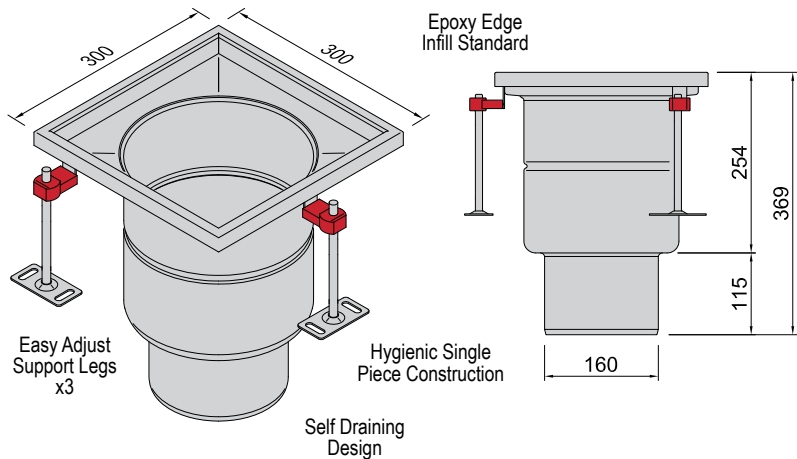

Ref	Item	Product No	Notes
G	Grate	See 'G3.SQ' grate options page AD37.	
FB	Filter Basket (Standard)	AD.FB3.075.03	3mm aperture
FBX	Filter Basket (Extended)	AD.FB3.200.03	3mm aperture
SB	Silt Basket (Solid Bottom)	AD.SB3.200.03	3mm aperture
FAT	Removable Foul Air Trap (FAT)	AD.FAT3.KIT	Flow Rate*: 4.6 L/sec
SS	Secondary Strainer Kit	AD.SSK.160.03	3mm aperture
DB	Drain Bowl	AD.DB3.SQS.160V	
PT	P-Trap	AP.PT.160	Flow Rate*: 7.5-28.5 L/sec

* Max rate based on a continuous flow of water in clean conditions. Accessories may reduce flow further.

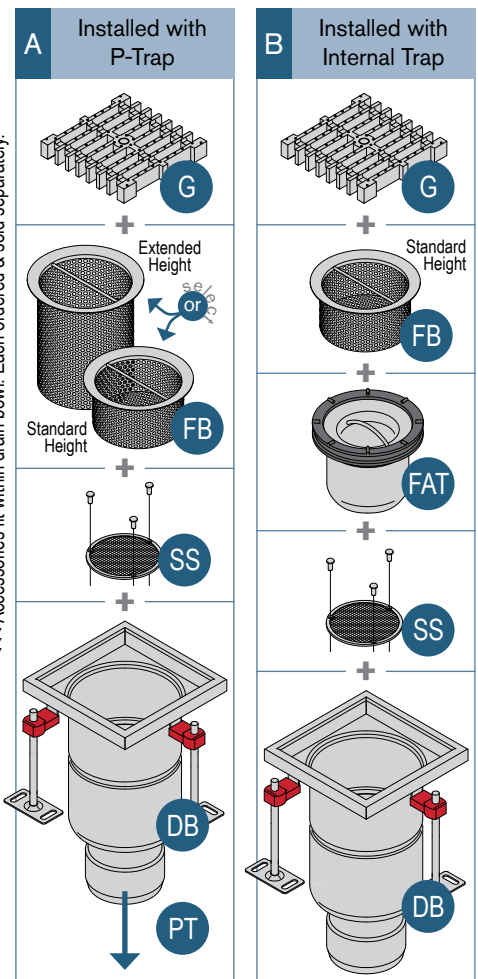

<<< Accessories fit within drain bowl. Each ordered & sold separately.

300

Drain Bowl 300 Square, Standard Height, 110-H Outlet

Material: 316L stainless steel body, epoxy infill hygienic & strong top edge.
Top: Square top for concrete, tiled or epoxy floor finishes.

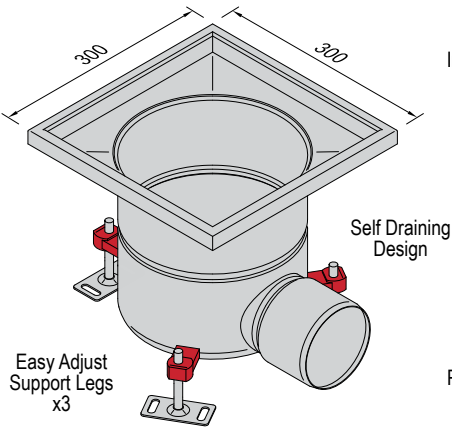

Epoxy Edge Infill Standard

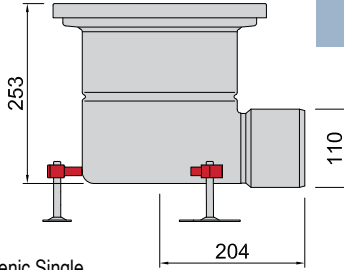

Note: Both a Standard Filter Basket and a 'FAT' must be used with this drain.

Ref	Item	Product No	Notes
G	Grate	See 'G3.SQ' grate options page AD37.	
FB	Filter Basket (Standard)	AD.FB3.075.03	3mm aperture
FAT	Removable Foul Air Trap (FAT)	AD.FAT3.KIT	Flow Rate [‡] : 4.6 L/sec
DB	Drain Bowl	AD.DB3.SQS.110H	

[‡] Max rate based on a continuous flow of water in clean conditions. Accessories may reduce flow further.

B Installed with Internal Trap

<<< Accessories fit within drain bowl. Each ordered & sold separately.

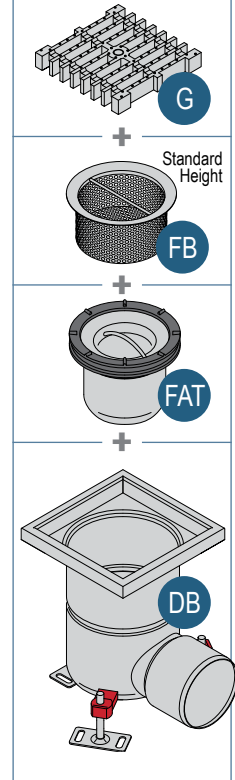

300

Drain Bowl 300 Square, Low Height, 110-V Outlet

Material: 316L stainless steel body, epoxy infill hygienic & strong top edge.
Top: Square top for concrete, tiled or epoxy floor finishes.

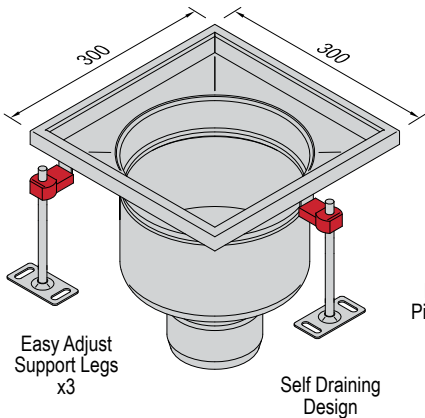

Epoxy Edge Infill Standard

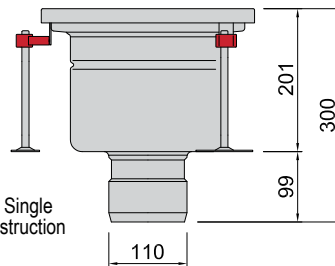

Note: The 'FAT' and/or Extended Filter Basket cannot be used with this drain.

Ref	Item	Product No	Notes
G	Grate	See 'G3.SQ' grate options page AD37.	
FB	Filter Basket (Standard)	AD.FB3.075.03	3mm aperture
SS	Secondary Strainer Kit	AD.SSK.110.03	3mm aperture
DB	Drain Bowl	AD.DB3.SQL.110V	
PT	P-Trap	AP.PT.110	Flow Rate [‡] : 3.4-10.4 L/sec

[‡] Max rate based on a continuous flow of water in clean conditions. Accessories may reduce flow further.

A Installed with P-Trap

<<< Accessories fit within drain bowl. Each ordered & sold separately.

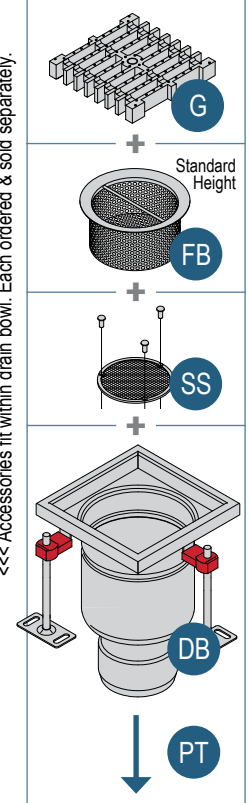



200 Drain Bowl 200 Round, Standard Height, 110-V Outlet

Material: 316L stainless steel body, solid stainless 10mm top edge.
Top: Round top for concrete or epoxy floor finishes.

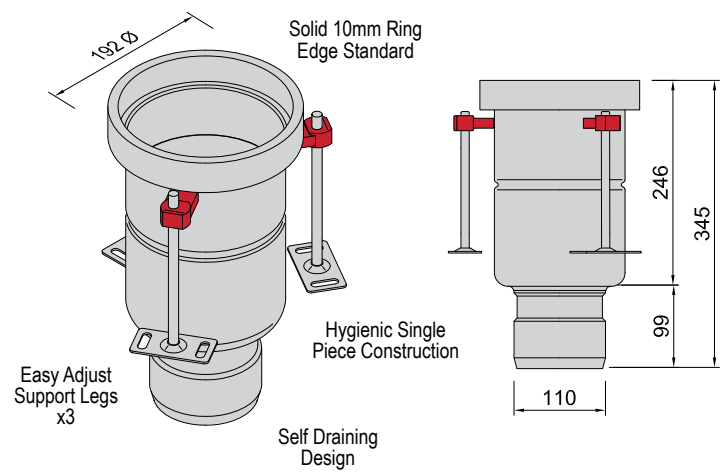

Ref	Item	Product No	Notes
G	Grate	See 'G2.RD' grate options page AD37.	
FB	Filter Basket (Standard)	AD.FB2.075.03	3mm aperture
FBX	Filter Basket (Extended)	AD.FB2.200.03	3mm aperture
SB	Silt Basket (Solid Bottom)	AD.SB2.200.03	3mm aperture
FAT	Removable Trap (FAT)	AD.FAT2.KIT	Flow Rate*: 3.6 L/sec
SS	Secondary Strainer Kit	AD.SSK.110.03	3mm aperture
DB	Drain Bowl	AD.DB2.RDS.110V	
PT	P-Trap	AP.PT.110	Flow Rate*: 3.4-10.4 L/sec

* Max rate based on a continuous flow of water in clean conditions. Accessories may reduce flow further.

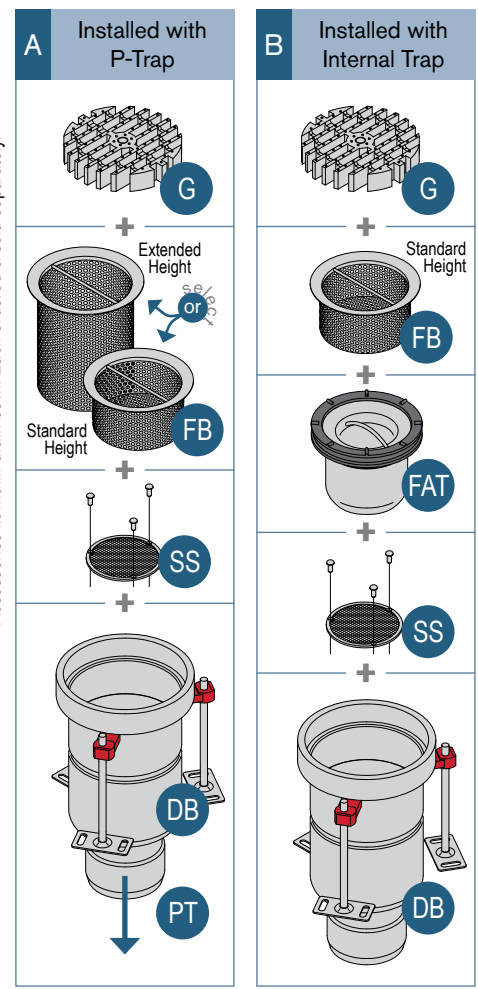

300 Drain Bowl 300 Round, Standard Height, 110-V Outlet

Material: 316L stainless steel body, solid stainless 10mm top edge.
Top: Round top for concrete or epoxy floor finishes.

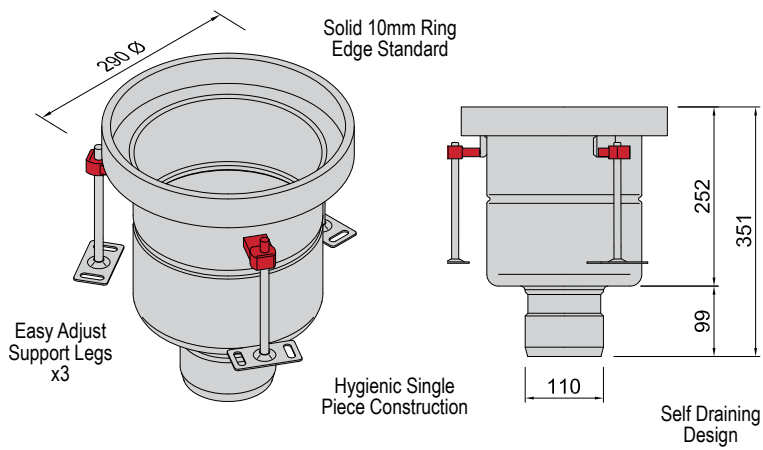

Ref	Item	Product No	Notes
G	Grate	See 'G3.RD' grate options page AD37.	
FB	Filter Basket (Standard)	AD.FB3.075.03	3mm aperture
FBX	Filter Basket (Extended)	AD.FB3.200.03	3mm aperture
SB	Silt Basket (Solid Bottom)	AD.SB3.200.03	3mm aperture
FAT	Removable Trap (FAT)	AD.FAT3.KIT	Flow Rate*: 4.6 L/sec
SS	Secondary Strainer Kit	AD.SSK.110.03	3mm aperture
DB	Drain Bowl	AD.DB3.RDS.110V	
PT	P-Trap	AP.PT.110	Flow Rate*: 3.4-10.4 L/sec

* Max rate based on a continuous flow of water in clean conditions. Accessories may reduce flow further.

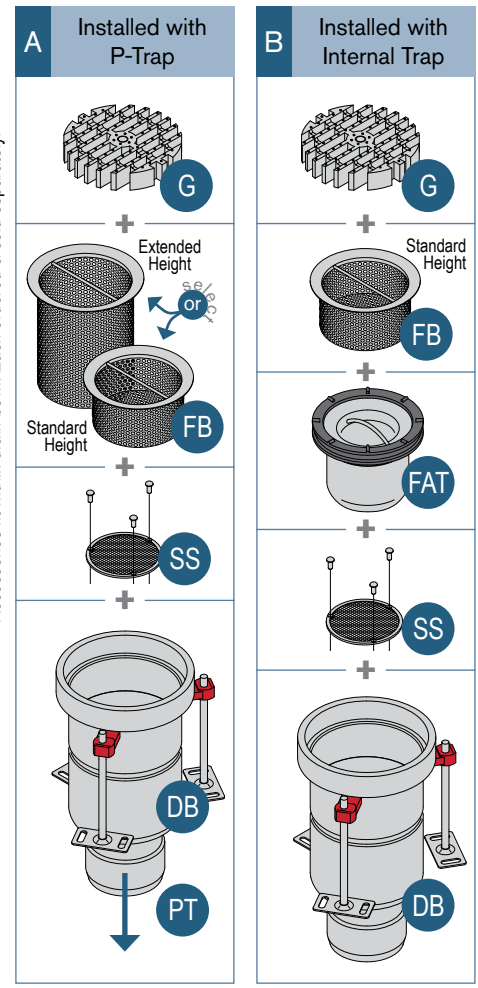

300

Drain Bowl 300 Round, Low Height, 110-V Outlet

Material: 316L stainless steel body, epoxy infill hygienic & strong top edge.
Top: Round top for concrete or epoxy floor finishes.

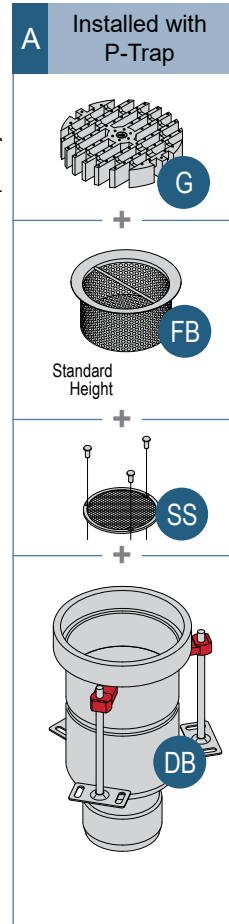
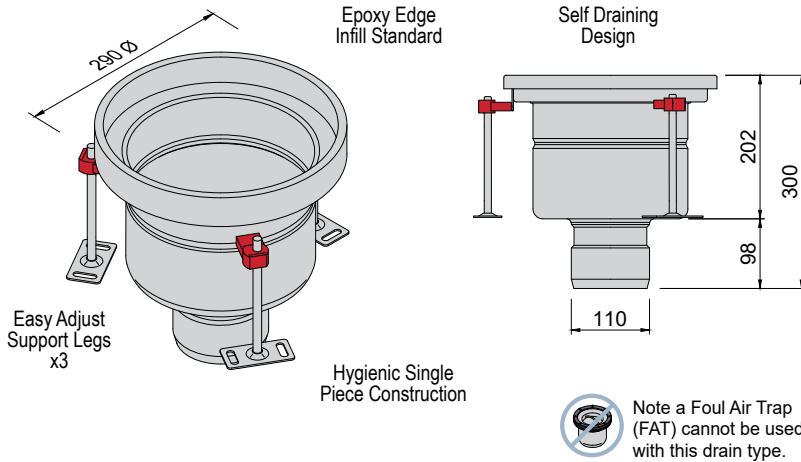

Ref	Item	Product No	Notes
G	Grate	See 'G3.RD' grate options page AD37.	
FB	Filter Basket (Standard)	AD.FB3.075.03	3mm aperture
SS	Secondary Strainer Kit	AD.SSK.110.03	3mm aperture
DB	Drain Bowl	AD.DB3.RDL.110V	
PT	P-Trap	AP.PT.110	Flow Rate†: 3.5-10.4 L/sec

† Max rate based on a continuous flow of water in clean conditions.
Accessories may reduce flow further.

300

Drain Bowl 300 Round, Low Height, 160-V Outlet

Material: 316L stainless steel body, epoxy infill hygienic & strong top edge.
Top: Round top for concrete or epoxy floor finishes.

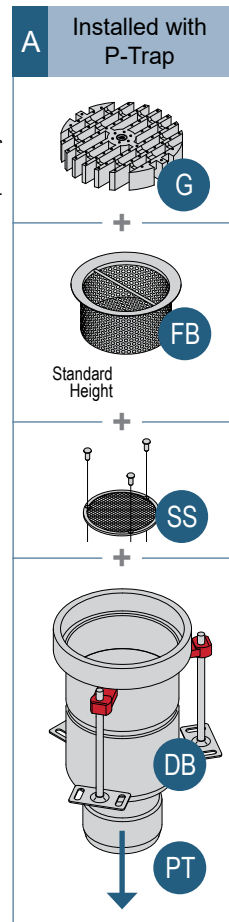
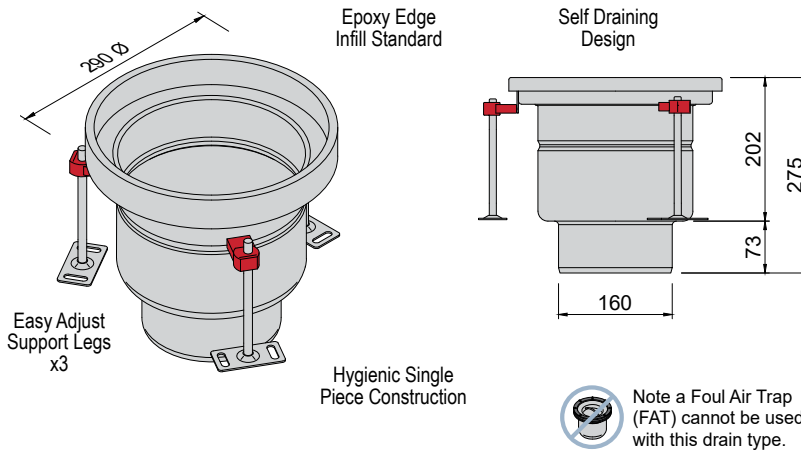

Ref	Item	Product No	Notes
G	Grate	See 'G3.RD' grate options page AD37.	
FB	Filter Basket (Standard)	AD.FB3.075.03	3mm aperture
SS	Secondary Strainer Kit	AD.SSK.160.03	3mm aperture
DB	Drain Bowl	AD.DB3.RDL.160V	
PT	P-Trap	AP.PT.160	Flow Rate†: 7.8-28.5 L/sec

† Max rate based on a continuous flow of water in clean conditions.
Accessories may reduce flow further.



400 XL

Drain Bowl 400 Square, Standard Height, 160-V Outlet

Material: 316L stainless steel body.
Top: Square top for concrete, tiled or epoxy floor finishes.

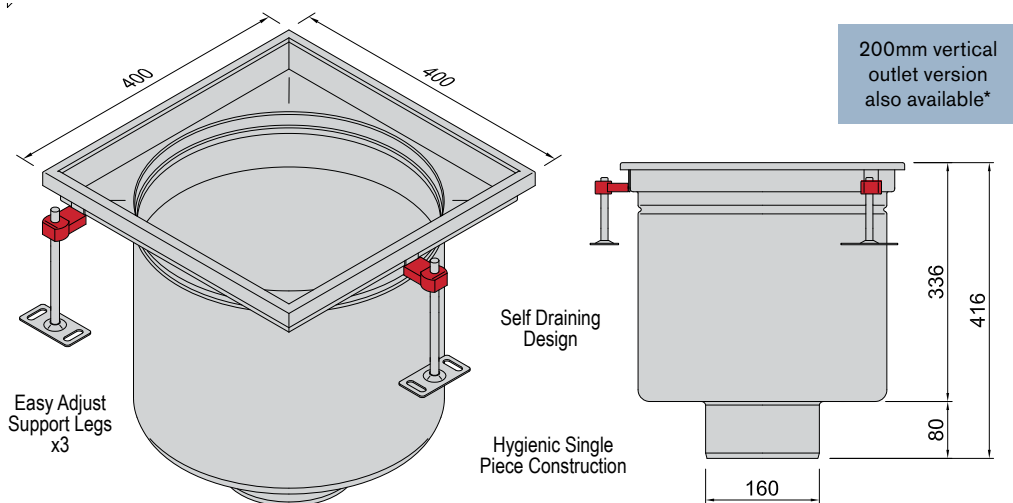

<<< Accessories fit within drain bowl. Each ordered & sold separately.

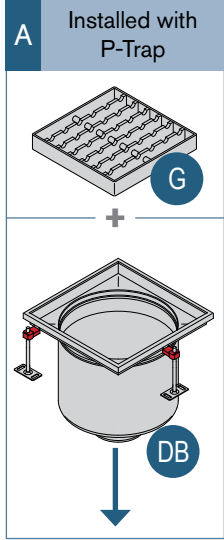

Ref	Item	Product No	Notes
G	Ladder Grate	AD.G4.SQ.L12	
FB	Filter Basket (standard)	AD.FB4.075.03	
FB	Filter Basket (extended)	AD.FB4.260.03	
FAT	Removable Trap (FAT)	AD.FAT4.KIT	Flow Rate [‡] : 10.0 L/sec
SS	Secondary Strainer Kit	AD.SSK.160.03	3mm aperture
DB	Drain Bowl	AD.DB4.SQS.160V	
PT	P-Trap	AP.PT.160	Flow Rate [‡] : 7.5-28.5 L/sec

[‡] Max rate based on a continuous flow of water in clean conditions. Accessories may reduce flow further.

600 XL

Drain Bowl 600 Square, Standard Height, 200-V Outlet

Material: 316L stainless steel body.
Top: Square top for concrete, tiled or epoxy floor finishes.

Ref	Item	Product No	Notes
G	Ladder Grate (568x284mm)	AD.G6.SQ.L12	2x required per Drain Bowl.
FB	Filter Basket	AD.FB6.270.03	3mm aperture
DB	Drain Bowl	AD.DB6.SQS.200V	Flow Rate [‡] : ~60.0 L/sec

[‡] Max rate based on a continuous flow of water in clean conditions. Accessories may reduce flow further.

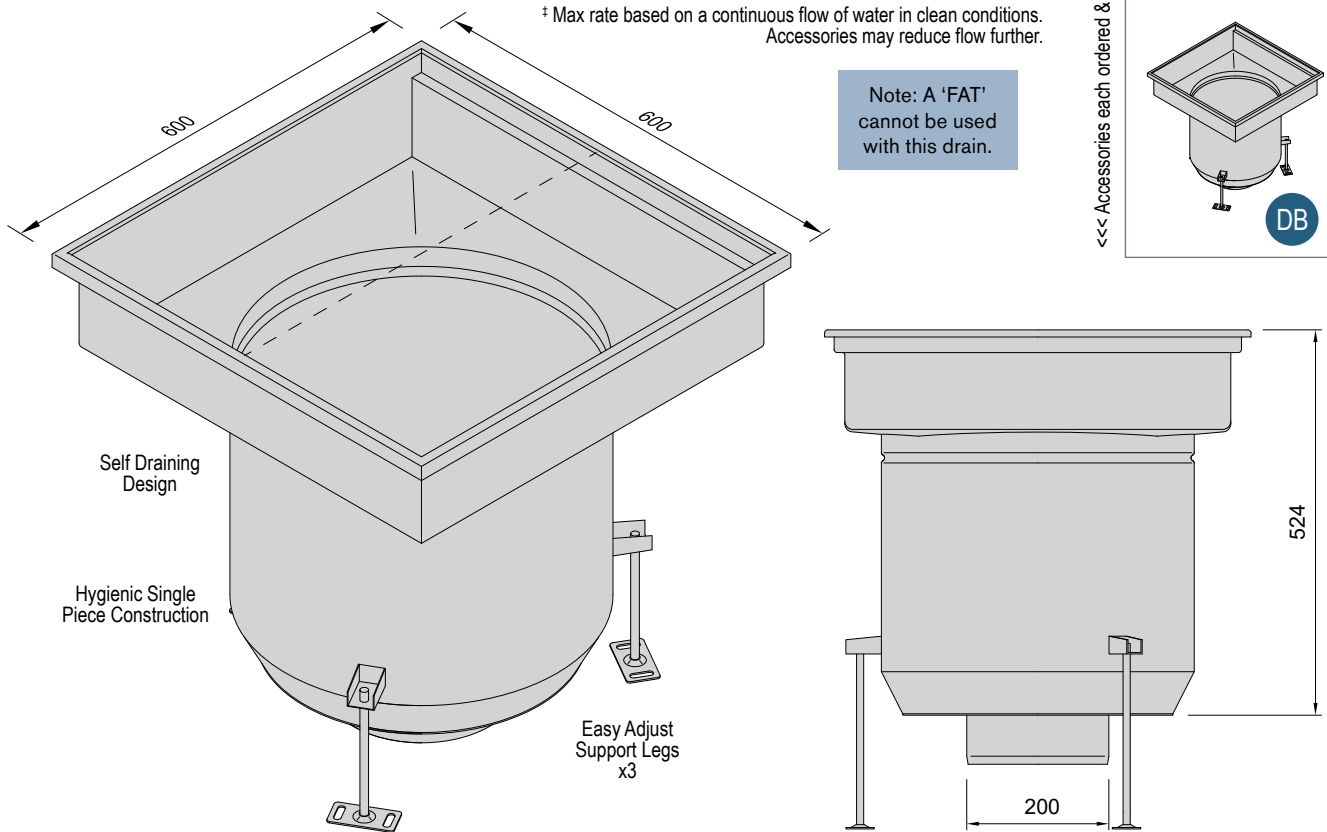

<<< Accessories each ordered & sold separately.

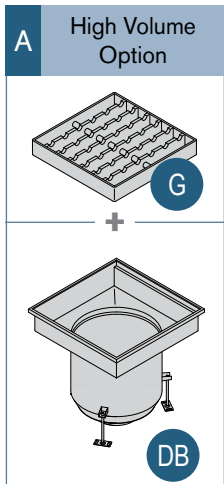

200

G2.SQ Grate Options

168x168mm for 200 Square Top Drain Bowls

Style	Product Number	Class	Ultimate Load
L	AD.G2.SQ.L12	B	4,250 [‡]
M	AD.G2.SQ.M	B	4,180 [‡]
C	AD.G2.SQ.C	B	3,570 [‡]
S	AD.G2.SQ.S	-	
W	AD.G2.SQ.W	A	300 [‡]
GTS	AD.G2.SQ.GTS	C	7,400 [‡]
GTP	AD.G2.SQ.GTP	C	7,400 [‡]
L5	AD.G2.SQ.L5	D	10,900 [‡]

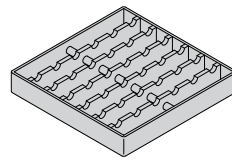

L Ladder Grate (L12 shown)
Material: 316 stainless steel.
Finish: Mill finish.

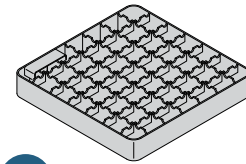

M Mesh Grate
Material: 316 stainless steel.
Finish: Electropolished.

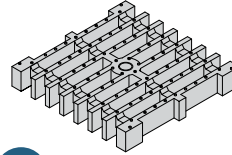

C Cast Hygiene Stainless Grate
Material: 316 stainless steel.
Finish: Smooth cast finish.

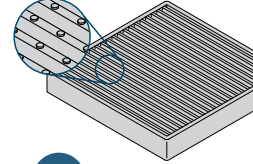

W Wedge Wire Grate
Material: 316 stainless steel.
Finish: Grip dimples.

300

G3.SQ Grate Options

268x268mm for 300 Square Top Drain Bowls

Style	Product Number	Class	Ultimate Load
L	AD.G3.SQ.L5	B	8,000 [‡]
M	AD.G3.SQ.M	A	1,020 [*]
C	AD.G3.SQ.C	B	8,160 [‡]
S	AD.G3.SQ.S	-	
W	AD.G3.SQ.W	A	300 [‡]
GTS	AD.G3.SQ.GTS	-	
GTP	AD.G3.SQ.GTP	-	

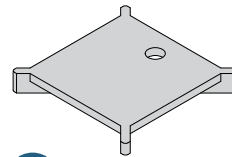

S Slot Grate
Material: 316 stainless steel.
Finish: Polished top.

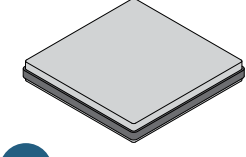

GTP Gas Tight Plain Cover
Material: 316 stainless & EPDM edge and base gaskets. Finish: Polished top.
Note: Lubricate seal before fitting.

400 XL

G4.SQ Grate Options

368x368mm for 400 Square Top Drain Bowls

Style	Product Number	Class	Ultimate Load
L	AD.G4.SQ.L12	-	
M	AD.G4.SQ.M	-	

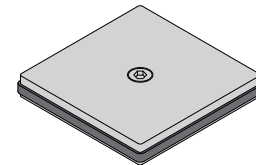

GTS Gas Tight Screw Cover
Material: 316 stainless & EPDM edge and base gaskets. Finish: Polished top.
Note: Lubricate seal before fitting.
Lifting Key Order a **AD.KEY** (sold separately) to install and remove

200

G2.RD Grate Options

Ø170mm for 200 Round & Vinyl Lock Drain Bowls

Style	Product Number	Class	Ultimate Load
C	AD.G2.RD.C	C	5,300 [‡]
L	AD.G2.RD.L5	-	-
M	AD.G2.RD.M	C	5,100 [*]
S	AD.G2.RD.S	-	
GTS	AD.G2.RD.GTS [‡]	-	
GTP	AD.G2.RD.GTP [‡]	-	
W	AD.G2.RD.W	-	

[‡] Item not suitable for vinyl lock drain types.

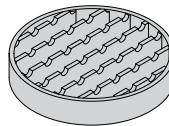

L Ladder Grate (L5 shown)
Material: 316 stainless steel.
Finish: Mill finish.

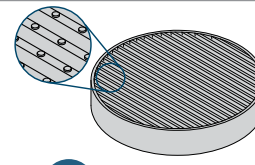

W Wedge Wire Grate
Material: 316 stainless steel.
Finish: Electropolished.

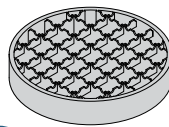

M Mesh Grate
Material: 316 stainless steel.
Finish: Electropolished.

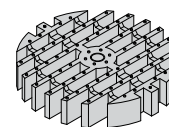

RC Round Cast Grate
Material: 316 stainless steel.
Finish: Smooth cast finish.

300

G3.RD Grate Options

Ø268mm for 300 Round Drain Bowls

Style	Product Number	Class	Ultimate Load
C	AD.G3.RD.C	C	14,990 [‡]
L	AD.G3.RD.L5	D	23,700 [‡]
M	AD.G3.RD.M	B	7,950 [‡]
S	AD.G3.RD.S	-	
GTS	AD.G3.RD.GTS [‡]	-	
GTP	AD.G3.RD.GTP [‡]	-	
W	AD.G3.RD.W	-	

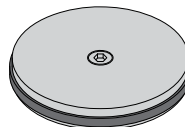

GTS Plain Cover - Screw
Material: 316 stainless & EPDM.
Finish: Mill finish. **Note:** Lubricate seal before fitting. **Lifting Key** Order a **AD.KEY** (sold separately) to install and remove

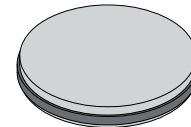

GTP Plain Cover
Material: 316 stainless & EPDM.
Finish: Polished top. **Note:** Lubricate seal before fitting.

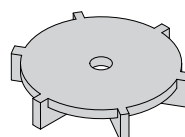

S Slot Grate
Material: 316 stainless steel.
Finish: Electropolished.

[‡] Load ratings to AS3996-2019 testing in kilograms (kg). Lesser values for solid wheel and moving wheel loads. Slip ratings tested to EN13036.

*Indicative load shown. Contact AusPress for further details. Refer to Tech Note TN.15



FS Flushing Sink Bench or Floor Install

Material: Polished 316L stainless steel body, WaterMark approved design for aged care, hospital and health facilities.

Flushing Sink Type?	<input type="checkbox"/> 'FCB' Bench Integrated	<input type="checkbox"/> 'FCC' Floor - Conc/Epoxy	<input type="checkbox"/> 'FCV' Floor - Vinyl Sheet
Sink Material?	<input type="checkbox"/> 316 Stainless	<input type="checkbox"/> 304 Stainless	
Outlet:	<input checked="" type="checkbox"/> 110mm OD		
Inlet:	<input checked="" type="checkbox"/> 1.1/2" MI BSP		
P-Trap?	<input type="checkbox"/> AP.PT.110		

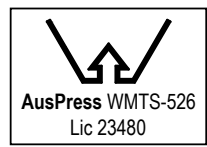
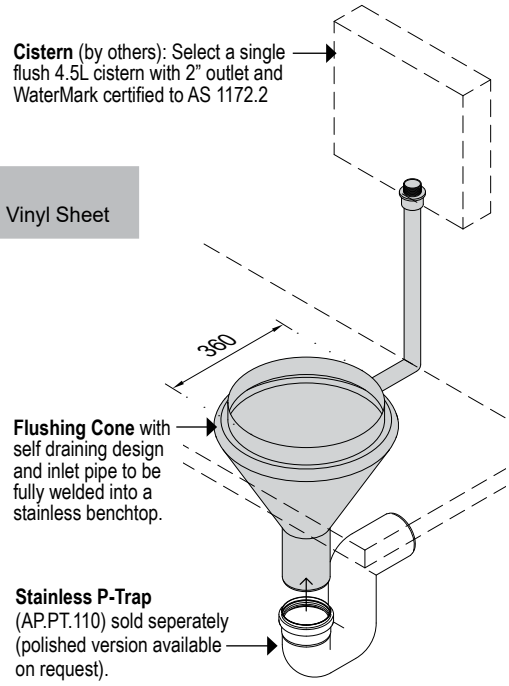

Visit our website for installation and product details.

FCB
FCB-Type, for Bench (pictured)

Filter Basket Options

Material: 316 stainless steel.

Why Use a Filter Basket?
The mesh of the Filter Basket prevents solids in wash down waters from passing and possibly blocking the drainage beyond so this material can be disposed of appropriately.

Why use a Silt Basket?
When wash down water contains fine or sand like solids, these particles fall to the solid bottom for collection and allow the water to overflow through the mesh and drain beyond.

Retaining Chain?
We can fix the basket to the drain bowl to prevent the basket being thrown away.

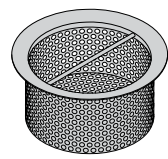

FB
'Standard' Height Filter Basket

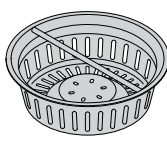

PB
Pressed Filter Basket

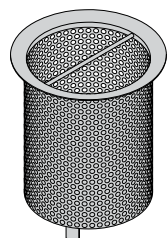

FBX
'Extended' Height Filter Basket
Cannot be used with a Foul Air Trap (FAT).

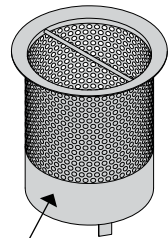

SB
Solid bottom to collect silt
Dry 'Silt' Basket with Solid Bottom
Cannot be used with a Foul Air Trap (FAT).

Product No	Image	Desc	for Bowl Size	Volume	Mesh
AD.FB2.075.03	FB	Filter Basket (Standard)	200 (157)	0.7 L	3.25Ø
AD.FB2.200.03	FBX	Filter Basket (Extended)	200 (157)	2.0 L	3.25Ø
AD.FB2.157.50	PB	Filter Basket (Pressed)	200 (157)	0.5 L	5.0Ø
AD.SB2.200.03	SB	Silt Basket	200 (157)	2.0 L	3.25Ø
AD.FB3.075.03	FB	Filter Basket (Standard)	300 (218)	1.9 L	3.25Ø
AD.FB3.200.03	FBX	Filter Basket (Extended)	300 (218)	6.2 L	3.25Ø
AD.FB3.218.50	PB	Filter Basket (Pressed)	300 (218)	1.1 L	5.0Ø
AD.SB3.200.03	SB	Silt Basket	300 (218)	6.2 L	3.25Ø
AD.FB4.075.03	FB	Filter Basket (Standard)	400 (350)	3.4 L	3.25Ø
AD.FB4.260.03	FBX	Filter Basket (Extended)	400 (350)	11.4 L	3.25Ø
AD.FB6.270.03	FBX	Filter Basket (Extended)	600 (520)	25.0 L	3.25Ø

† Max rate based on a continuous flow of water in clean conditions with vertical outlet drain bowl.

Foul Air Trap (FAT) Removable

Material: 316 stainless steel with NBR seal.

Why Use A FAT?
With the Fowl Air trap removed, pipework beyond is clear for maintenance access.

Use instead of a P-Trap to reduce the IL depth of the outlet.

FAT must be used with a standard height Filter Basket in a standard height Drain Bowl (all sold separately).

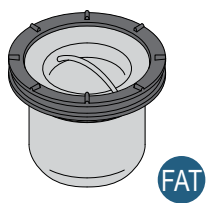

Product No	for Bowl Size	Seal Height	Flow†
AD.FAT2.KIT	200 (157)	75	3.5 L/sec
AD.FAT3.KIT	300 (218)	75	4.6 L/sec

† Max rate based on a continuous flow of water in clean conditions with vertical outlet drain bowl.

Secondary Strainer Option

Material: 316 stainless steel.

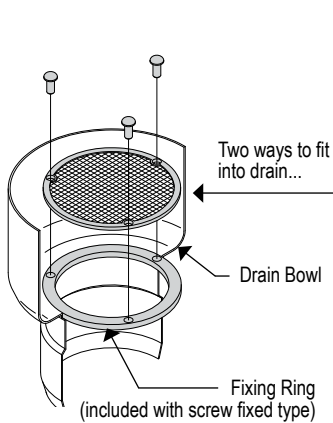

Strainer (Screw Fixed)

Secured with 3x torx screws to the Drain Bowl outlet. Screw Fixed available on request.

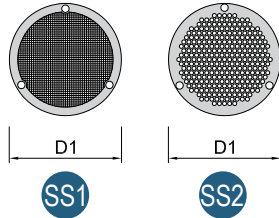

Outlet OD	Aperture	Style	Product No	Open %
110	3.2mm	SS1	AD.SSK.110.03	42%
160	3.8mm	SS1	AD.SSK.160.03	43%

Requirements for Trade Waste:
Some Water Authorities list 'Screw Fixed' Secondary Strainers as a standard requirement. Please ask if you're unsure.

Key to remove? Order a **AD.KEY**

Strainer (Clip-In)

With 3x support legs, no fixing ring required (not shown).

Outlet OD	Hole Dia	Style	Product No	Open %
110	3.8mm	SS2	AD.SSC.110.03	36%
160	3.8mm	SS2	AD.SSC.160.03	41%

P-Trap Socket - Spigot

Material: 316 stainless steel, mill finish.
Ring Seal: EPDM x1 fitted.

Riser	Product No	D1	X4
A small vertical length may be required. Riser length sold separately.	APP.015.110	110	225
	APP.025.160	160	345

P-Trap	Product No	D1	X1	X2	X3	Flow Rate [‡]
	AP.PT.110	110	132	300	254	3.4-10.4 L/sec
	AP.PT.160	160	190	403	347	7.5-28.5 L/sec

[‡] Max rate based on a continuous flow of water in clean conditions with 20mm head.

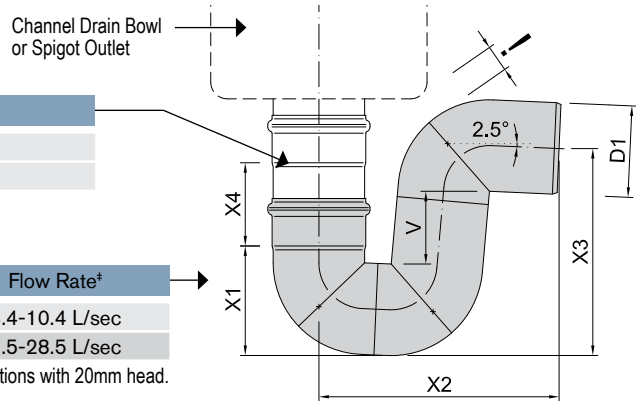

Bend 45° Socket - Spigot

Material: 316 stainless steel, mill finish.
Ring Seal: EPDM x1 fitted.

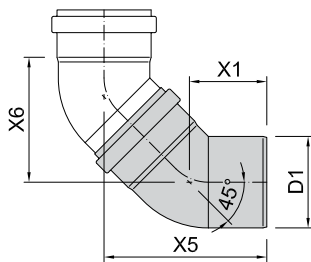

Double 45 bend arrangements shown for offset dimensions only - each bend sold separately.

Product No	D1	X1	X5	X6
AP.B.45.110	110	93	195	150
AP.B.45.160	160	131	269	200

Mini Filter Basket

Material: 316 stainless steel.

When use the Mini Basket?

With a collection volume of 300mL, the Mini Basket is used when solids are few in washdown water.

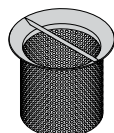

FB 'Mini' Filter Basket
Suitable to selected 110mm spigot outlets.

Mesh	Hole	Product No
3mm	3.25Ø	AD.FB1.075.03

Suits items with a 110mm spigot outlet.

Clearout (IP Cover)

Material: 316 stainless steel, polished top finish.
Lid seal: Neoprene gasket.

Polished 316 stainless steel top finish.
Allen head screws fitted standard.
Security screws are available on request.

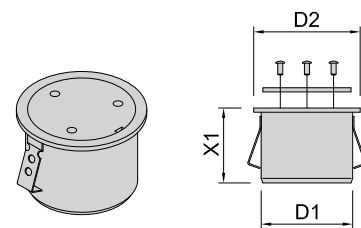

Product No	D1	D2	X1
AP.CO.110	110	128	90
AP.CO.160	160	180	100

Retaining Chain

Material: 316 stainless steel.

A Retaining Chain can be fitted between the Filter Basket and the Drain Bowl to prevent the basket being left out of the Drain Bowl or discarded.

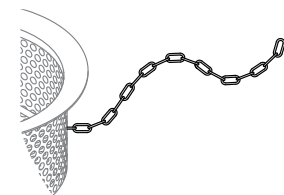

Length	Product No
700mm	AD.RCK.0700*



Floor Gully Invert Chart

Configurations show the minimum invert level (IL) for each drain bowl type, using AusPress stainless P-Trap and 2x 45 Bend scenarios.



Partnering with ACO



Symbol indicates a Foul Air Trap (FAT) cannot be used with this drain type.

Refer to our drainage catalogue for more information.

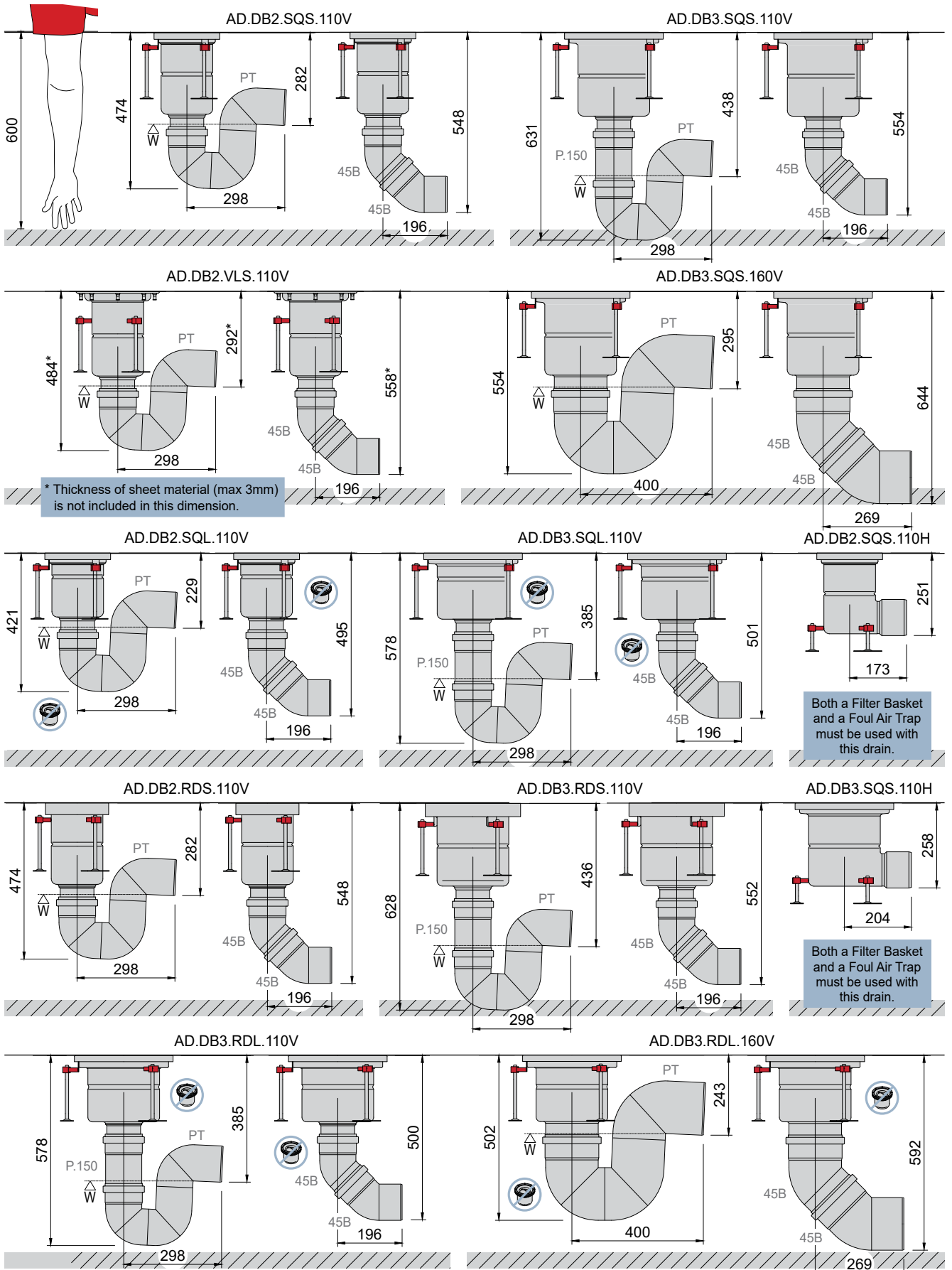

Notes: Installation in accordance with AS/NZS 3500.2 and local building regulations by a licenced plumber. All items sold separately. Different accessories offer different flow rates. Dimensions allow for 10mm pipe movement. Confirm dimensions onsite before installation.