



The Strength of Press-Fit

It's All In The Join

The socket on each press fitting is fitted with a rubber ring seal, engineered to provide both a strong and sealed joint after being pressed with a press tool.

By using a calibrated press tool, each joint is permanent and uniform as the joint is deformed in two ways;

The engineered shaping of the fitting against the tube to provide strength to the join as the primary seal plus,

The deformation of the rubber ring seal to form the secondary seal in the encapsulated pocket between the fitting and tube.

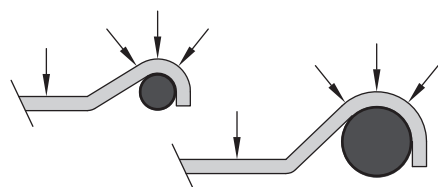
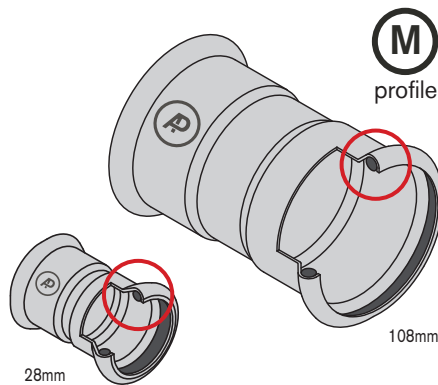

M-Profile: All diameters from 10 to 168.3mm feature the same turned down end that the ring seal is seated.

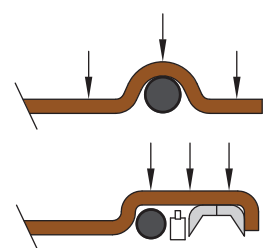
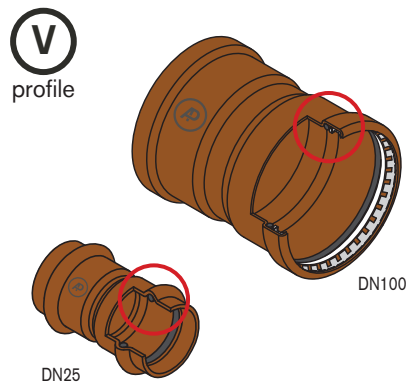

V-Profile: Diameters DN50 and smaller have a flat tail continuing past the ring seal.

V-Profile: Diameters DN65 and above feature a flat socket lip that a grab ring, spacer and ring seal are seated.

The press jaw (or collar) determines the shape and it is important to ensure the jaw (or collar) used with the press tool matches not only the diameter but also the fitting profile to ensure a successful pressed joint.

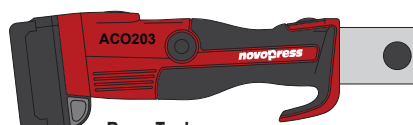

Press Tool
Available in a range of sizes and abilities.



Press Jaw
Insert into tool directly.



Adaptor Jaw + Press Collar
Insert jaw into the tool, jaw clamps onto collar.

Above: Press Tools are fitted with an interchangeable jaw or, adaptor jaw and collar combination depending on the fitting material, system diameter and fitting press profile to be pressed. All must match for the press to be successful.

Since the original M-Profile was invented by Larsson, other profiles have been developed based on his design. Although appearing to be similar, each profile performs with different strength, deformation and ability characteristics.

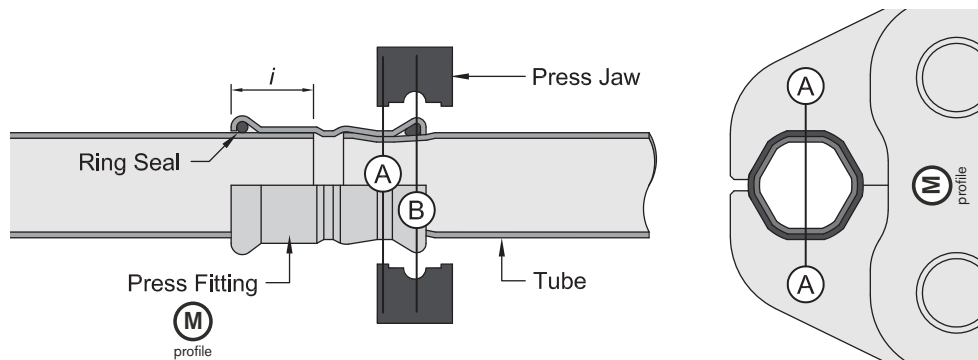

Above: Hexagonal shape section profile - Before pressing (fitting left), after pressing (fitting right) & Section A through pressed joint.

Did You Know?
Originally designed in 1962 by Swedish engineer Gunther Larsson, the first press fittings were manufactured by German company Mannesmann from 1969.

Two different cross section shapes are pressed depending on the tube diameter - the hexagonal and the lemon shape.

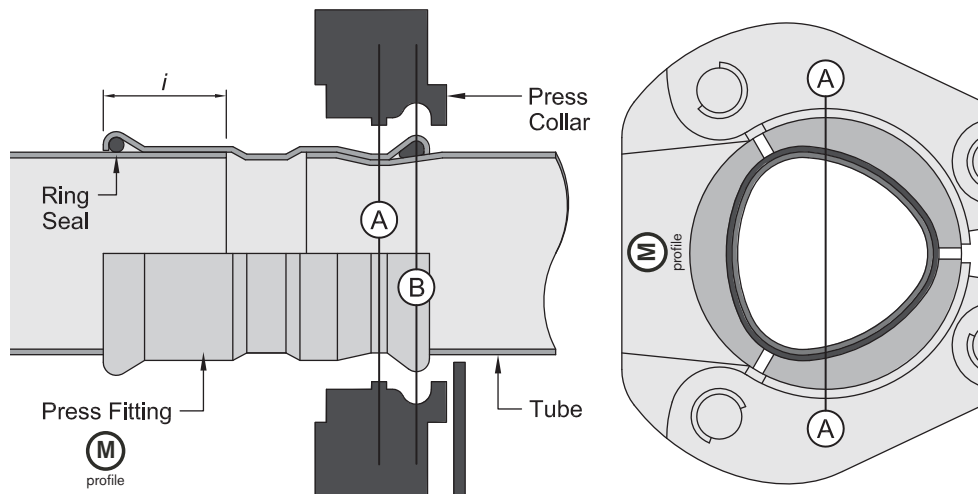

Above: Lemon shape section profile - Before pressing (fitting left), after pressing (fitting right) & Section A through pressed joint.

Section A:
This forms the mechanical strength of the pressed joint.

Section B:
The deformation of the rubber ring seal ensures a permanently tight joint.

Using a Press Tool

The Tool Does All The Work

Press Tools are designed specifically for the installation of press fittings and come in a range of shapes and sizes. They often have an on-board computer that controls the press pressure, duration and other quality control parameters that is recorded on the press tool.

Press fittings can only be pressed with a press tool that is fitted with the correct jaw or collar that matches the profile type and diameter of the fitting. After a successful press, a permanent joint between the fitting and the tube is made.

Different press tools have different abilities and determine the working pressure of the completed system so use the 'Select a Press Tool' charts at the start of each section to check for suitability.

Every press tool is slightly different so check with the tool manufacturer for their specifications and operating instructions.

Read in conjunction with the Installing AusPress guide at the start of each catalogue section.

- 1 Check the press jaw (A) or collar (B+C) matches the profile and diameter of the fitting and is suitable for the press tool.
- 2 Retract the retaining pin (RP) of the tool and insert the jaw into the press tool. Once seated, close the retaining pin.
- 3 Open the press jaw and align the inner groove of the jaw with the raised profile of the fitting.
- 4 Check the fitting is fully engaged by the insertion depth mark and if so, press and hold the start button (GO) to begin the press.
- 5 Once complete the tool will 'click' and retract the internal roller pins. Open the press jaw and move away from the fitting.
- 6 An occasional spray with Inox lubricant on the jaw moving parts and press zone will ensure ongoing smooth operation.

Tool, Jaw & Collar Calibration

Tool calibration show when next due for calibration.



Example shows due 08/2022

Half or Cancelled Press?

If the press tool operation is stopped before completing a full press cycle, the press tool must reset before removing the jaws. **Press fittings cannot be re-pressed.**

Tool Training & Safety

For OH&S and product warranty reasons, before using a press tool you must of completed the relevant AusPress Tool Training.

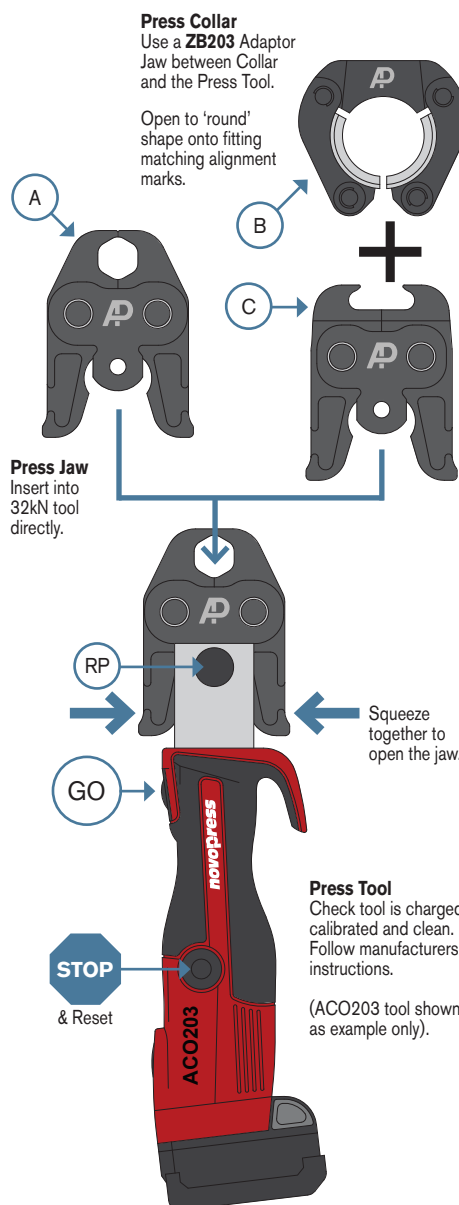

Use the Right Tool...

The Press Tool used determines the maximum working pressure of the installation.

Use the 'Select a Press Tool' chart to check suitability.



Safety & Tool Training

We offer on-site tool training and maintain records of attendees for OH&S and Quality Assurance.

Tool Servicing

We're authorised press tool repair & service centre for our Novopress & Vetec tools.

Tool Maintenance Every 10x Presses:

Lightly lubricate inside press zone groove of jaws & collars with an Inox spray.

Weekly:

Lubricate and inspect press jaws and collars for wear or damage.

Regular Servicing:

Refer to manufacturer's tool manual for service interval & warranty details.

Tool Not Working?

Press the Reset Button?
LED status?
Contact Us...

Green LED

Off = Tool is on standby or press is in progress.
Steady = Tool is ready.
Flash = Check retaining pin or Battery Charge.

Red LED

Steady = Fault / Service.
Flash (x3) = Extreme temperatures or tool fault.

Red & Green LEDs

Flash = Service.

Generators

Please contact us before using generators with the 240V Press Tools.

Batteries

Press tools generally don't commence a press unless there is enough battery charge to complete a press.



Jaw & Collar Clearances

Images show AusPress metric M-Profile stainless steel fittings & nominated Novopress tools. Measurements are dependant on the actual tool and fitting used; best to confirm before proceeding with your installation.

Copper AV-Profile fittings are similar, measured from the end of the leading fitting lip. Refer to our AusPress Copper catalogue section for more information.

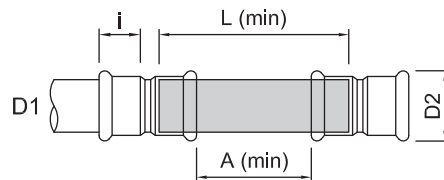

D1: M-Profile Fitting Size	15	18	22	28	35	42	54	66.7	76.1	88.9	108	139.7	168.3
i : Press socket insertion depth	22	23	23	26	29	32	37	51	54	61	82	98	126
D2: Press socket seat OD	23	26	32	38	45	54	66	84	95	110	133	165	195
L: Min tube length	54	56	56	62	78	84	94	122	128	142	184	256	312
A: Min exposed tube length	10	10	10	10	20	20	20	20	20	20	20	60	60

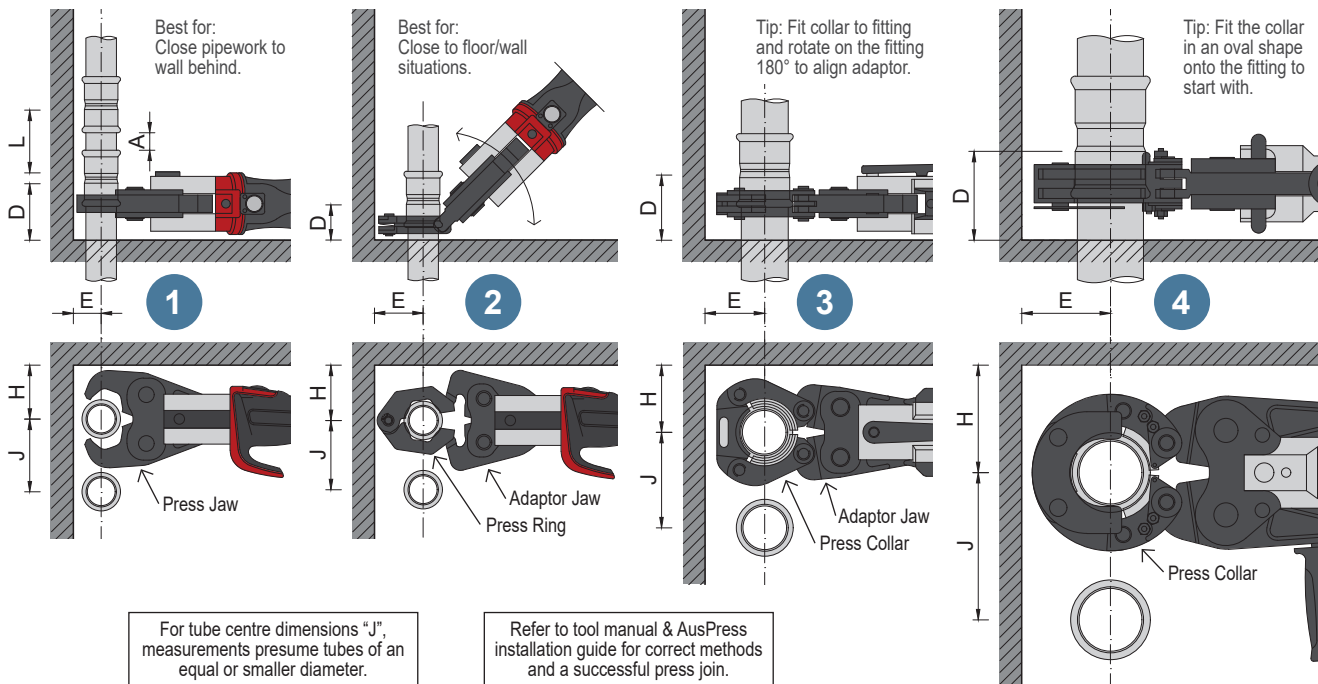

For tube centre dimensions "J", measurements presume tubes of an equal or smaller diameter.

Refer to tool manual & AusPress installation guide for correct methods and a successful press join.

1 Press Jaws + ACO203	M15	M18	M22	M28	M35	AV15	AV20	AV25	AV32	AV40	AV50
E: Tube center offset wall	24	24	29	29	32	24	29	29	32	37	56
D: Tube length from wall	62	63	63	65	68	62	63	65	68	61	65
J: Tube-Tube centre spacing	60	61	71	73	84	60	71	73	84	99	130
H: Tube centre from side wall	59	59	59	59	62	59	59	59	62	75	99





2 Press Rings + ACO203	M15	M18	M22	M28	M35	AV15	AV20	AV25	AV32	AV40	AV50
Adaptor:	SZB201	-	SZB201	SZB201	SZB201	SZB201	SZB201	SZB201	SZB201	SZB202	SZB202
E: Tube center offset wall	43	-	48	54	56	43	47	52	57	62	69
D: Tube length from wall	38	-	38	40	43	26	27	28	30	35	43
J: Tube-Tube centre spacing	54	-	58	72	80	52	60	70	77	89	109
H: Tube centre from side wall	61	-	62	62	64	56	59	59	61	92	96

3 Press Collars + ACO203-XL	HP28	HP35	M42	HP42	M54	HP54	M66.7	M76.1	M88.9	M108	AV65	AV80	AV100
Adaptor(s):	ZB201	ZB201	ZB201	ZB201	ZB201	ZB201	ZB221	ZB221	ZB221	ZB221 ZB222	ZB201	ZB201	ZB201
E: Tube center offset wall	56	62	62	67	69	70	85	94	100	115	82	88	101
D: Tube length from wall	65	68	71	67	75	70	78	81	88	109	71	80	91
J: Tube-Tube centre spacing	86	93	99	107	110	115	145	162	182	214	121	135	181
H: Tube centre from side wall	67	71	81	72	77	82	104	117	128	148	93	90	123

4 Press Collars + ACO403	HP76	HP88	HP108	M139	M167
E: Tube center offset wall	102	113	132	140	164
D: Tube length from wall	102	109	134	161	192
J: Tube-Tube centre spacing	169	193	219	263	289
H: Tube centre from side wall	124	138	152	180	195

Material Performance

Material Compositions

								
		AISI 316L	AISI 304	90/10	C12200	CW602N	CW511L	AISI S31803
Grade No:		1.4404	1.4404	2.1972	DHP	DZR†	LF	1.4462
Aluminium (Al)	%	-	-	-	-	<0.05 - 0.1	<0.05	-
Arsenic (As)	%	-	-	-	-	0.02 - 0.15	0.02 - 0.15	-
Chromium (Cr)	%	16.5 - 18.5	18 - 19.5	-	-	-	-	21.0 - 23.0
Carbon (C)	%	<0.03	<0.03	<0.05	-	-	-	<0.03
Copper (Cu)	%	-	-	>85.6	>99.9	61 - 63	61.5 - 63.5	-
Iron (Fe)	%	bal	bal	1.5 - 1.8	-	0.1 - 0.2	<0.1	bal
Lead (Pb)	%	-	-	0.01	-	1.7 - 2.8	<0.1	-
Manganese (Mn)	%	<2	<2	<1	-	<0.1	-	<2
Molybdenum (Mo)	%	2 - 2.5	-	-	-	-	-	2.5 - 3.5
Nickel (Ni)	%	10 - 13	8 - 10.5	10 - 11	-	<0.3	<0.3	4.5 - 6.5
Nitrogen (N)	%	-	-	-	-	-	-	0.08 - 0.20
Phosphorus (P)	%	<0.045	<0.045	<0.02	<0.04	-	-	<0.03
Silicon (Si)	%	<1	<1	-	-	-	-	<1
Sulphur (S)	%	<0.015	<0.03	<0.005	-	-	-	<0.02
Tin (Sn)	%	-	-	-	-	0.1 - 0.2	0.1	-
Zinc (Zn)	%	-	-	<0.05	-	bal (~36)	bal (~37)	-
Zirconium (Zr)	%	-	-	<0.01	-	-	-	-
PREN	ave	24.9	18.8	-	-	-	-	34.2

† DZR type brass is considered a non-compliant copper alloy as per NCC 2022 and not suitable for installation where in contact with potable (drinking) water from May 2026. The new brass type defined as "lead free" in the NCC is available with product fittings and bags marked with "LF". Refer to AusPress Tech Note TN.37 Material Specifications for more information.

Temperature Correction Factor

The graph below shows the correction factor (Kc) based on the water temperature.

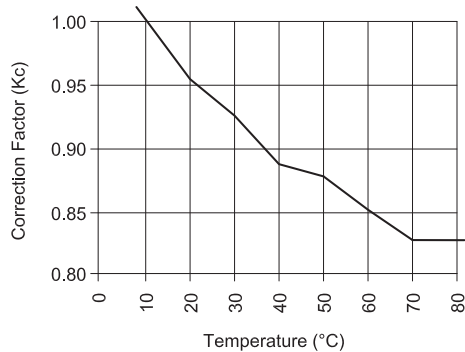

Batch Numbers (Tube & Fittings)

Our fittings and tubes are marked with a batch (or heat) number identifying the material as part of our 3.1 certifications for our stainless products.

Tube: '3.1 Cert' Reference starts C-...

Did You Know? WaterMark notation.

OF = Operation of Fabrication Code
 '17' = raw material coil number,
 '9' = mill number,
 '3' = employee number,
 '8' = test produced material certificate.

Example only

Pressure Loss & Flow Rates

The graph adjacent shows the relationship between pressure loss, flow velocity for each diameter.

Test Details
 Material: Stainless Steel 316L
 Media: Potable Water
 Test Temperature: 10°C
 Surface Roughness Coefficient: 0.0015mm (average)

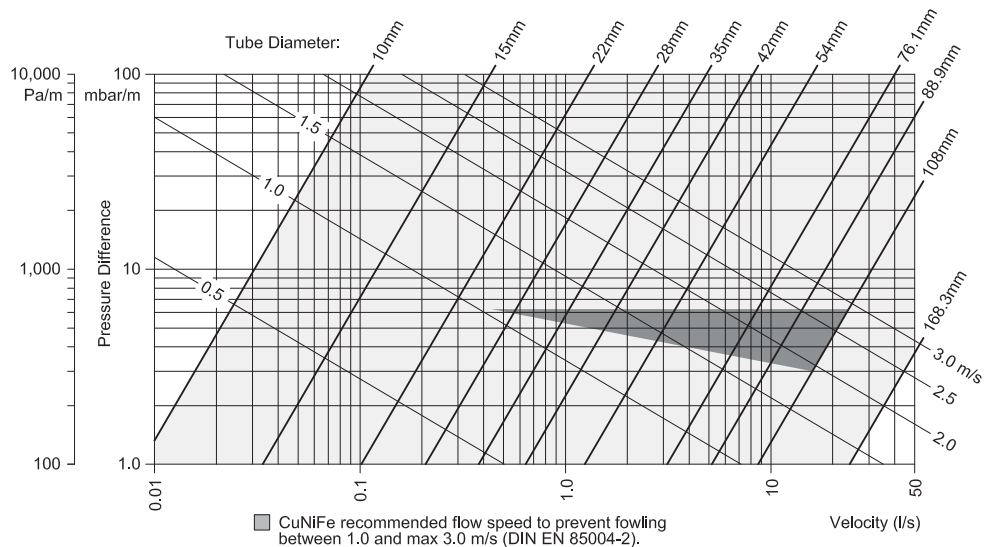

For further details refer to TN.30



Design for Press-Fit

This information is suitable for 'normal' applications within the abilities of press-fit including potable water and compressed air however some applications require additional consideration; these include (but not limited to) steam, pressurised oil lines and chemical lines. In these instances, contact us before installation for technical assessment.

The following information is a general guide only. For project & application specific assessment, contact us directly.



Tech Notes Available

Contact us for Technical Notes that cover topics in much greater detail.

1: Ring Seal (Elastomer) Suitability

The rubber ring seal is an important part of the press fitting join and must be assessed as suitable for the application and media to be used. AusPress fittings are supplied with a pre-fitted EPDM (black) ring seal standard, unless otherwise noted at the time of ordering. We don't recommend the swapping of ring seals from one type to another after the time of ordering.

Refer to our AusPress Suitability Guide for specific ring seal suitability and limits and/or contact us for confirmation before installation by completing a Project Information form available from our website.

2: System Pressures

Maximum working pressure depends on a combination of the press tool used to install, the fitting profile, fitting diameter, the system material, operating temperature and application (use) as approved by AusPress. Some applications are limited to a lesser pressure despite the system able to achieve higher; in these cases, the lesser pressure is used.

Working Pressure – 'normal' operating pressure, designed for and in accordance to relevant standards.

Test Pressure – 1.5x the working pressure, during site test conditions only (see Pressure Testing section).

For suitability of other press tools, applications and limits for



Refer to the 'Select a Press Tool' page at the beginning of each AusPress catalogue section to find the right tool for your project.

AusPress products, please contact us for advice.

3: Insulation & Lagging

Insulating AusPress is suitable however consideration must be given to the piping material and the insulation type to be installed. *Tech Note available.*

For example, insulation materials used with stainless 316 must be specified 'low chloride' (less than 0.05% soluble chloride ion content by weight). This issue is critical to the performance of stainless installations at any temperature. **(For further info refer to TN.04)**

4: Threaded Fittings & Sealants

Support the threaded press fitting using the fixed nut to tighten and prevent torsional forces being applied to the pressed join.

For threads, both thread tapes and liquid/paste sealants must be chloride free and suitable with the material and application.

Contact us for more information.

5: Bracketing

Install bracketing & centres (spans) to AS/NZS 3500 & AS/NZS 4041 as required appropriate to the application.

Bracketing is to be the same material as the pipework or separated with an inert lining such as rubber.

Brackets are not to be positioned directly on a fitting.

Refer to the Expansion & Contraction section for bracket type and positioning. **(For further info refer to TN.20)**

6: Bending Tubes

Tube up to 35mm diameter can be cold bent using a commercial tube bender to a radius no less than 3.5x the tube diameter. Do not heat stainless or CuNiFe to bend.

7: Material Suitability

AusPress is suitable for a range of applications; please complete a Project Info Form and contact us for product suitability based on your project requirements.

Press-Fit for Potable Water

AusPress systems are resistant to potable water meeting the requirements of the Australian Drinking Water Guidelines (ADWG) 2011.

Stainless & copper are resistant due to the protective layer these materials create naturally. The content of water-soluble chloride ions at ambient temperature (including in potable water) should not exceed 250mg/l (250ppm).

Copper Nickel (CuNiFe) is not suitable for potable water applications but can be tested with potable water.

Problems can occur with high chloride content found in some chlorous disinfectants or naturally occurring sources such as bore water. Confirm suitability with AusPress before use.



Stagnant water, low flow periods and dead legs require caution and are not recommended.

Water analysis testing by a NATA certified laboratory is required to confirm the composition of waters.

Press-Fit for Purified Waters

Purified waters such as softened, de-carbonised, fully desalinated, de-ionised, de-mineralised, distilled and pure condensates are suitable. Ultrapure water with a conductivity of > 0.1 µS/cm is also suitable. No additional measures to protect against corrosion are necessary.

Other types are to be confirmed before installation on request.

Water sample and parameters may be required. Note Copper and CuNiFe are not suitable for purified water types.

Press-Fit for Chemicals, Disinfectants and Additives

Please complete a Project Info Sheet with the relevant MSDS and contact us to check the suitability.

Press-Fit for Compressed Air

Dry or wet (lubricated) systems are suitable with AusPress; use the FKM ring seal for wet systems or when oil is possible.

Press-Fit for Wet Steam

Only the Red FKM ring seal is suitable for wet steam. Water quality and additives must be confirmed as suitable. For AusPress stainless, max limits of 75 psi (550 kpa) & 160°C installed with pressure relief valve, temp gauge & suitable press tool. Contact us for advice and the *Tech Note*.

Press-Fit for Oil, Fuels, Grease & Viscous Liquids

Systems must be installed with a thermal expansion safety valve, the pump isolated and system depressurised during non-operational periods. Confirm the ring seal suitability before installation. *Tech Note available*.

Press-Fit for Sewer, Stormwater or Gravity Waters

Press-Fit is not suitable, designed or approved for these applications. Contact us for information about our range of stainless drainage pipes and floor drains.

Press-Fit in Cold Climates

Allowance must be allowed for expansion of water within the pipework that may freeze. Various methods such as trace heating are used, please contact us for specific advice.

8: Protecting External Surfaces

Material Resistance

Despite the robust protective layer to the material formed naturally, the external environment and conditions must be considered; contaminants settling or in contact for a period of time may effect the outside surface of the tube & fittings.

For example;

316 stainless is susceptible to chlorides; coastal areas where the tube is exposed, unwashed or buried;

Building materials in contact such as concrete, galvanised brackets or grinding sparks;

Chemicals (including cleaning), alkaline or acidic environments where AusPress is to be installed;

Underground installation of press-fit is not recommended where protection from damage, interference from plant roots or soil/groundwater conditions is not provided. Refer our Tech Note for more information. **(For further info refer to TN.01)**

Protection of External Surfaces

In areas at risk of unsuitable external conditions, installation of AusPress without protection is not recommended - contact AusPress for advice before installation.

To prevent against direct contact issues, installing press-fit using off-set brackets, material separation (such as inert rubber spacers) and other 'material' solutions is suitable.

Covering the external surface can protect and insulate the surface from contaminants. Care to prepare the press-fit surface before applying the covering is critical to prevent locking any contaminants between the tube and protection.

Protection against external contaminants must be waterproof and non-porous and resistant to heat and ageing and continuous (no gaps or damage). The use of encased or sealed blanket insulation, allowing to drain trapped condensation and barrier wrapping are all recommended. Materials that retain moisture including felts are not recommended.

Effects of Bi-Metal (Mixed) Installations

Caused by the direct connection of different materials or the water passing from one material to another (the flow rule), bimetallic reactions can effect some metals.

AusPress stainless is not effected by the flow rule and with potable water can be used with other nonferrous metals although this is not a preferred method of installation.

Colouring caused by deposits of other metals does not necessarily indicate corrosion.

Materials that do bimetallicly react are separated by an inert section to reduce the reaction.

For example, if stainless is directly connected to galvanised steel pipe, bimetallic reaction will occur to the galvanised steel. This can be prevented by:

Installing an inert separation piece between the two or;

Fitting a ball valve made of non-ferrous material.

9: Flushing the System

It is best practice to avoid the introduction of foreign matter or contaminants during installation including dirt and swarf. Flushing the pipework is recommended to reduce the negative effects contaminants may cause and AS/NZS 3500 has further directions for flushing water supply systems.

Flushing Water Systems: Potable water is recommended.

Flushing Air, Oil & Gas Systems: Use oil-free air or an inert gas such as carbon dioxide or nitrogen. Oxygen or other flammable gasses are not to be used.

Flush main-line separately before connection.

10: Pressure Testing

Conduct the pressure test in accordance with AS/NZS 3500 (and AS/NZS 2419.1 for Fire Hydrant applications).



If the system is to be emptied again after a water pressure test, or not remain completely full, it is advisable to conduct the pressure test with air in order to avoid an increased risk of pitting and corrosion.

Testing with Water: Potable water is recommended.

Testing with Air: Use oil-free air or an inert gas such as carbon dioxide or nitrogen. Oxygen or other flammable gasses are not to be used.

Water Supply Systems:

Flush the system then fill with potable water so that it is free from air pockets before commencing the test. If connecting to an existing water supply, flush any connecting pipework before connection.

Hot and Warm Water Systems:

In addition to the notes above for Water Supply Systems, conduct the preliminary and main tests with cold water first. As soon as possible after a successful cold water test, slowly heat up the system to the full designed hot water temperature and re-inspect for any issues.

Note the system will expand when heated and bracketing should not be fully tightened nor insulation fitted before normal operating temperature has been reached.



LPG and Natural Gas Systems:

Conduct the pressure test of the system in accordance with AS/NZS 5601. Water is not a suitable medium for testing, use the air testing method.

Pressure Test Process:

We recommend using the Test Protocol Form to record the test results as a record that can be downloaded from our website. Use the more stringent requirements of those listed below and the relevant AS/NZS standard to your installation.

	Test Pressure (the greater of):		Minimum Test Time Required:
AS/NZS 3500	1,500 kPa or...	1.5 times the maximum operating working pressure for the system.	45 minutes
AS/NZS 5601	7.0 kPa (pipework only) or...		2 minutes temp stabilisation time + 5 minutes for test
AS/NZS 2419.1	1,700 kPa or...		4 hours
Refer to the relevant standard for specific requirements of testing.			

For hot water systems, the duration may be longer allowing for the water to heat after the first cold water test.

For flange pressures, consult the relevant standard (i.e. AS/NZS 2129 for Table & ASME B16.5 for ANSI).

System considered 'passed' if:

No pressure drop over the test duration (as per relevant AS/NZS for the installation) and a visual inspection confirmation of no leaks or deformation.

11: Disinfecting the System

Prior to commissioning the system or in the event of microbial contamination, the Australian Drinking Water Guidelines (ADWG) recommend the use of hydrogen peroxide to disinfect pipework. Chlorine is also listed as suitable in this context.

Please contact us so we can offer project specific advice before you proceed.

Familiarise the manufacturer's safety precautions of using the chemical and instructions for use, particularly in relation to the contact time, maximum solution concentration and subsequent flushing requirements.

The Australian water regulations allow dosing with up to 1.2ppm of free chlorine in the disinfectant solution, provided a limit of 0.3ppm of free (active) chlorine is not exceeded in the drinking water.

Quantities can be increased to 6ppm and 0.6ppm respectively in exceptional circumstances for example, high or increased micro-bacterial contamination.

To prevent damage to AusPress products during disinfection, do not exceed the maximum chlorine concentration and contact times as tabled:

	Option 1	Option 2
Maximum concentration of free chlorine in water:	100ppm	50ppm
Maximum contact time:	16 hours	24 hours
Thorough flushing with potable (drinking) water:	Residue free chlorine in potable (drinking) water < 1ppm.	
1ppm = 1mg/L		

12: De-Scaling

Limescale on the bore tubes can be caused by a variety of service conditions including high water temperatures or excessively 'hard' water quality.

Additives for de-scaling tubes must be checked for suitability with the pipe material, rubber seal ring and approved for use with AusPress before use.

When using any solution, ensure the system is flushed correctly and the manufacturer's instructions are followed in an accurate and safe manner at all times.

13: Commissioning

Systems must be commissioned in accordance with the applicable standards and regulations.

The installation contractor must familiarise the owners and users with the system. This is to be documented with a hand-over and acceptance documentation.

Completing an *Operation and Maintenance Manual* is recommended to record the actual products installed, the ring seals used and the installer's information for future reference.

14: Operation and Maintenance

The user (or owner) of the system is under an obligation to ensure the system is maintained in a serviceable and safe condition at all times.

The system must be operated in such a way that faults and other factors affecting the reliability of the system are resolved before a hazard or issue occurs.

Ongoing maintenance includes assessing the interior and exterior of the pipework with regular inspections and timely rectification if required.

Avoid damage by keeping the system clean & free of contaminants, protect from sparks, grindings and confirm changes in media before making changes to operating conditions.

The user is advised to enter into a maintenance agreement with an installation contractor.

novopress

Tools and operating pressure

	PN10* (burst pressure: 40bar)	PN12,5* (burst pressure: 50bar)	PN16* (burst pressure: 64bar)
 ACO153 Jaws: M12-M35, V12-V35			
 ACO203 Jaws: M12-M35, V12-V54 Collars: M42-M54, V42-V54			Collars: HP28-HP54
 ACO203XL Jaws: M12-M35, V12-V54 Collars: M42-M108, V42-V54			Collars: HP28-HP54
 ACO403 Collars: 114.3-168.3		Collars: HP88.9-HP108.0	Collar: HP76.1

* depending on fitting

Press Profiles

In Australia there are typically three press profiles. AusPress Stainless Press and CuNi Press utilise the high performance of M-Profile globally accepted since 1962. Each Press Profile is joined utilising specific jaws targeting exertion points to maximise allowable pressure within the system. AusPress utilises M-Profile, which is capable of 40 bar* pressure.

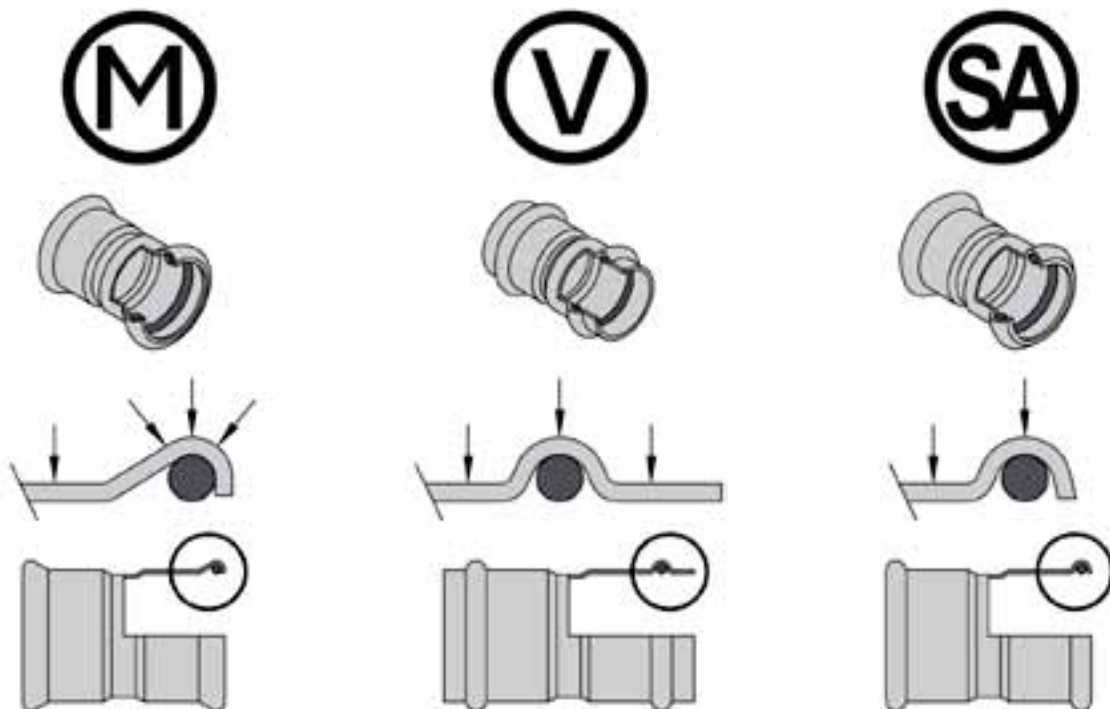

* 40 bar pressure rating dependant on pipe size, temperature and tooling used.