

Commonly used for very high chloride environments commonly found with seawater, bore water & offshore applications.



profile



15 to 108mm

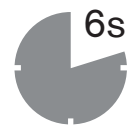

Press a 28mm fitting onto the CuNi tube in under 6 seconds. Join done.

Faster to Install

AusPress press-fit offers large time savings compared to welding, threading, grooving or glueing.

Quality to Install

Approved to International & Shipbuilding Standards. Superior temperature & chloride tolerance.

Safer to Use

- We train your team on-site.
- One button tool operation.
- Lightweight battery tools.
- No flames or hot work permits.
- No heavy gas tanks.
- No hazardous fumes.
- Less risk.

Reliable Design

Suits a wide range of applications. Permanent high strength with the original 'M' press join profile. Consistent low profile join look & quality each time.

Experience Counts

We were the first to supply press-fit stainless in Australia & New Zealand. We work with consultants & installers on specialised complex projects regularly.

Environmental Choice

Long service life. Closed loop material. Efficient and waste free install.

Installing AusPress®



OD 15 to 108mm

Start to install quicker...

AusPress press-fit is installed easily & quickly using a Press Tool to form a permanent 'M' profile pressed joint between tube and fitting.



Start here

Check for suitability...

Both the piping material (eg copper nickel) and the elastomer (the rubber ring seal) must be checked if suitable for the conveyed fluid and exterior environments.

This guide is for standard applications. For different or specialised applications please contact us first.

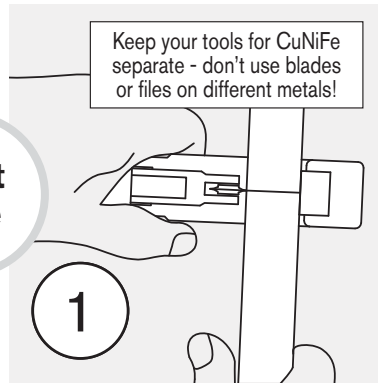

Cut to Length

Cut the tube square using a tube cutter with an 'inox' suitable blade. For larger sizes, cut square with an 'inox' blade using a stainless rotary cutter or 5" thin blade grinder disc.

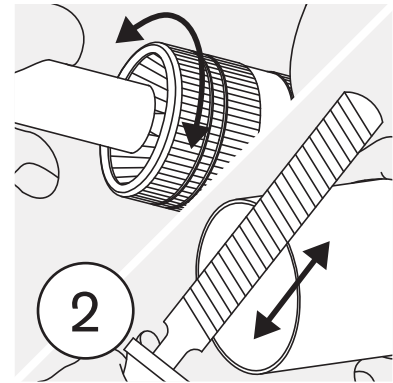

Deburr Tube

Deburr both inside & outside edges of tube ends to avoid cutting the ring seal on insertion. For large sizes, use a half round smooth file reserved for CuNiFe.

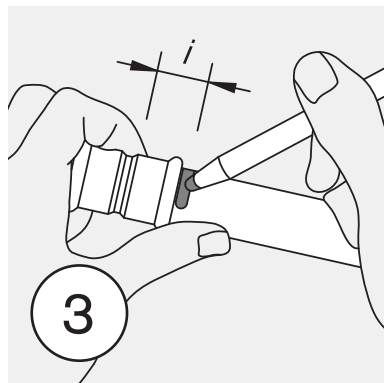

Mark the Insertion Depth "7"

Measure or use a depth gauge to mark the insertion depth (socket depth) onto the tube end.

This is a visual quality control mark to ensure the tube is fully inserted.

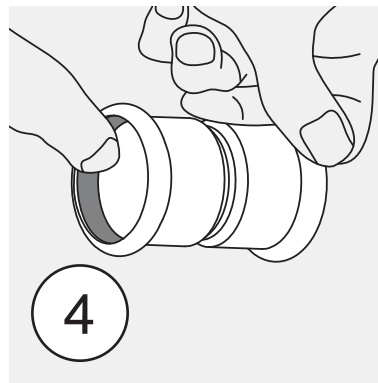

Inspect Fitting & Ring Seals

Check that the rubber ring seal is:

- The correct material type (colour) of seal is used.
- The seal is not damaged.
- Both fitting & seal are free of debris.

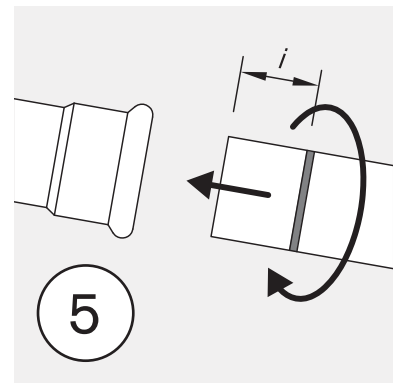

Join the Tube & Fitting

Insert the tube into the fitting press socket, turning slightly until it reaches the previously marked insertion depth.

Soapy water can be used if joining is difficult.



Press the Joint

Using a suitable press tool and M-profile jaw or collar, align the press jaw with the fitting and join following the tool manufacturer's instructions.

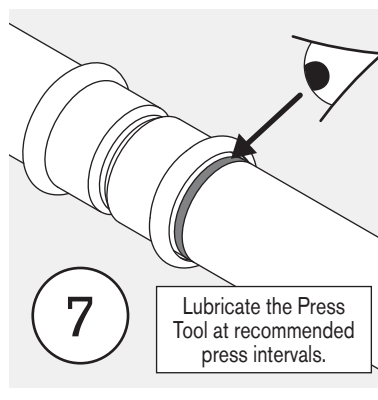

Check & Complete

Visually inspect the pressed fitting & that the insertion mark is aligned with the end of the socket.

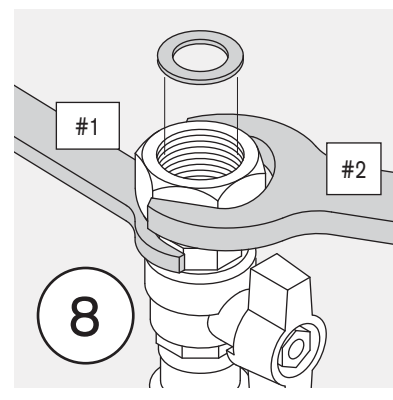

Threaded Ends

Tighten threads with the fitting supported, don't tighten against a pressed joint alone.



Select a Press Tool

The right tool for the job...

Our fleet of tools are designed to install AusPress press-fit quickly & consistently without the need for welding or threading to form a permanent join.

Confirm your project suitability before installing as some applications are limited to a lower pressure despite the system able to achieve higher; in these cases, the lesser pressure is used.

Refer to the technical section and contact us for more information.

Shipping & Offshore Applications

Note requirements for shipping are specific to the approval certificate for that vessel and operating pressures are often lower than the 16 bar approved for land based applications. The approval may also nominate a brand of tooling.

Chart below shows tool compatibility and maximum working pressure per diameter for a water installation up to 85°C.

OD AusPress Metric CuNiFe fittings and metric tube.



The 'M' Profile Press...

AusPress CuNiFe Metric fittings are supplied with a M-Profile press socket.

The press tools, jaws and collars we supply are designed to suit M-Profile and although they may look similar to other types, the tolerances of others may be different. Using incorrect tooling may effect warranty as a result.

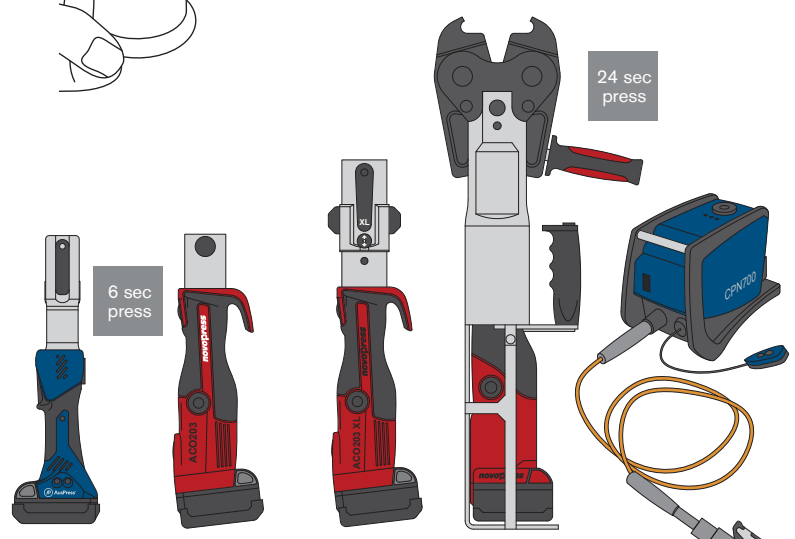

		SPM24	ACO203	ACO203-XL	ACO403	CPN700
15 to 35mm	Press Jaw	16 bar 232 psi 1,600 kPa	16 bar 232 psi 1,600 kPa	16 bar 232 psi 1,600 kPa	N/A	16 bar 232 psi 1,600 kPa
42 & 54mm	ZB203 Adaptor Jaw & Collar	N/A	16 bar 232 psi 1,600 kPa	16 bar 232 psi 1,600 kPa	N/A	16 bar 232 psi 1,600 kPa
76.1 to 108mm	Adaptor Jaw(s) & Collar	N/A	N/A	16 bar 232 psi 1,600 kPa	16 bar* 232 psi* 1,600 kPa*	16 bar 232 psi 1,600 kPa

Please Note: This chart is a guide only with other tool and application suitability available on request. Values noted are *Maximum Working Pressure*, not the safety or testing pressure of the system. More information is available in the technical section and contact us.

* Not suitable for gas or compressed air installations (76.1, 88.9 & 108 'HP' collars with the ACO401 or ACO403 tools).

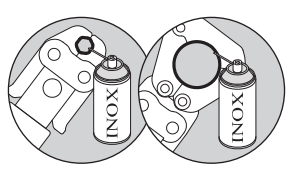

Ensure the inner press surfaces are lubricated with InOX for a smooth consistent press. Reapply as needed.

AusPress Metric Stainless Range



Refer to our Technical Data Sheets for material suitability and resistance.

Why Choose Copper Nickel?

Designed specifically for seawater applications, Copper Nickel has a much higher tolerance to chlorides and is the choice of material for shipping and offshore applications.

Please ask us if you require more information or technical advice for your project.

For technical information for specialised projects please ask us. With over 30 years of experience, have access to testing metallurgist services too.

Tube Bending:

Tube diameters up to 35mm can be cold bent with a commercial bender to a radius no less than 3.5x the tube diameter.

Eg: 15 (tube dia) x 3.5 = 52.5mm radius min along the centre line.

Tube Metric OD Stainless

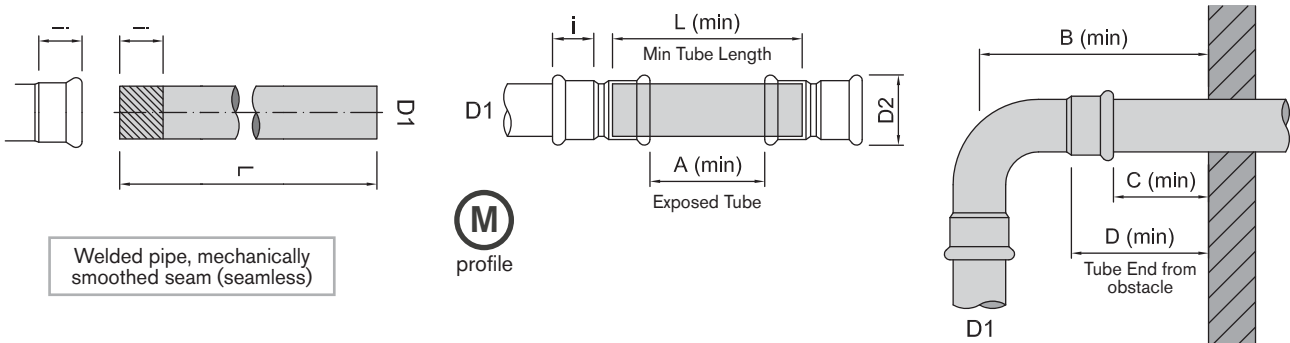

Welded pipe, mechanically smoothed seam (seamless)



Tool Jaw & Collar Clearance? See the technical section for dimensions to install press-fit clear of obstructions.

i = insertion depth. Tube must be inserted into the press socket a minimum distance to ensure the joint is pressed successfully.



Product No	D1 (mm)	i depth	Length (L)	Thk (t)	Tube Weights (kg)				L	A	D2	B	C	D
					dry/m	dry/6m	wet/m	wet/6m						
CUNI.96.015	15	20	6m	1.0	0.4	2.3	0.5	3.1	50	10	23	85	35	55
CUNI.96.018*	18	21	6m	1.0	0.5	2.9	0.7	4.1	52	10				
CUNI.96.022	22	21	6m	1.0	0.6	3.5	0.9	5.4	52	10	32	95	35	56
CUNI.96.028	28	24	6m	1.5	1.1	6.7	1.6	9.6	58	10	38	107	35	58
CUNI.96.035	35	27	6m	1.5	1.4	8.4	2.2	13.3	74	20	45	121	35	61
CUNI.96.042	42	32	6m	1.5	1.7	10.2	2.9	17.4	84	20	54	147	35	65
CUNI.96.054	54	38	6m	1.5	2.2	13.2	4.2	25.5	96	20	66	174	35	70
CUNI.96.076	76.1	55	6m	2.0	4.1	24.9	8.2	49.4	130	20	95	223	75	128
CUNI.96.088	88.9	64	6m	2.0	4.9	29.2	10.5	63.1	148	20	110	249	75	135
CUNI.96.108	108	78	6m	2.5	7.4	44.2	15.7	94.2	176	20	133	292	75	150

Installation Tools

These items make installing AusPress press-fit easier.

Remember using the same cutting or deburring tool on different metals can lead to corrosion (eg cut steel then cut stainless steel).

Press Tools:

Information and capacities are listed under "Select a Press Tool" Section.

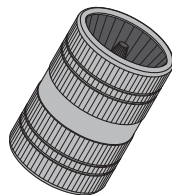

Tube Deburrer
Inside and outside diameter cones, suits diameters 10 - 54mm.
Order: VT.DEB



Replacement Inox Cutting Wheels (each)
Suitable for both cutters shown.
Order: VT.TCUT.WHEEL

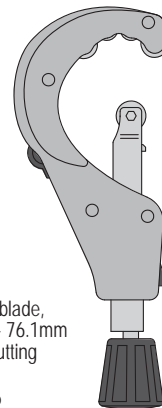

Manual Tube Cutter
Metal construction, Inox blade, suitable for diameters 6 - 76.1mm OD. Includes 1x spare cutting wheel in handle end.
Order: VT.TCUT.006.076



Rubber Ring Seals

Fittings are supplied with an NBR type ring seal as standard in each press-socket.

Note: Some chemical types and/or high concentrations can be unsuitable.

Please contact us for suitability confirmation before installing, with a Project Info Sheet and any MSDS details or laboratory test results.

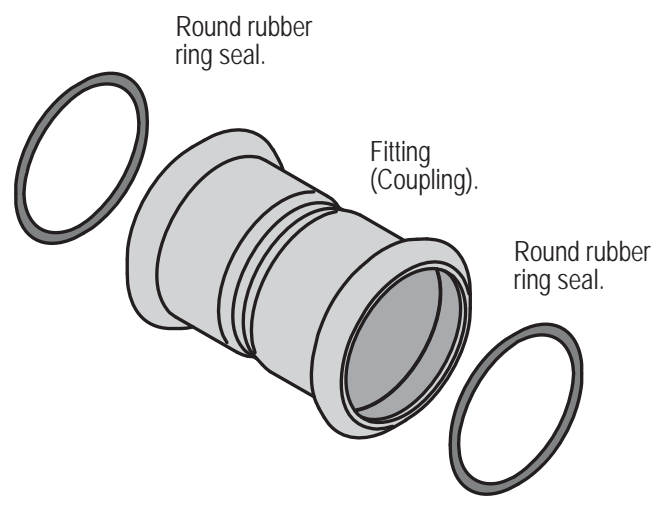

Coupling Socket - Socket

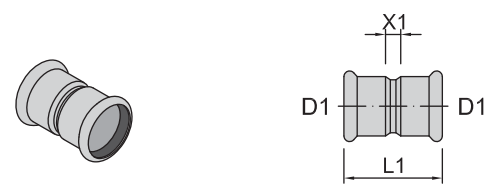

Material: CuNiFe (2.1972.11).

Ring Seal: NBR x2 supplied.

Product No	D1	L1	X1
CUNI.21.015	15	56	16
CUNI.21.018	18	55	13
CUNI.21.022*	22	51	9
CUNI.21.028	28	56	8
CUNI.21.035	35	68	14
CUNI.21.042	42	74	10
CUNI.21.054	54	94	18
CUNI.21.076	76.1	125	15
CUNI.21.088	88.9	158	30
CUNI.21.108	108	183	27

Spigot Reducer Socket - Tube End

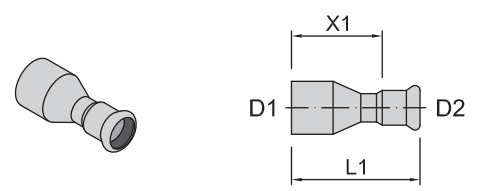

Material: CuNiFe (2.1972.11).

Ring Seal: NBR x1 supplied.

Product No	D1	D2	L1	X1
CUNI.23.022.015*	22	15	72.5	55
CUNI.23.028.015	28	15	80	51
CUNI.23.028.022	28	22	77	52
CUNI.23.035.022	35	22	85	64
CUNI.23.035.028	35	28	83.5	67
CUNI.23.042.028	42	28	96.5	76
CUNI.23.042.035	42	35	103	75
CUNI.23.054.035	54	35	116	89
CUNI.23.054.042	54	42	118	86
CUNI.23.076.042	76.1	42	157	126
CUNI.23.076.054	76.1	54	157	119
CUNI.23.088.054	88.9	54	168.5	137
CUNI.23.088.076	88.9	76.1	180	125
CUNI.23.108.076	108	76.1	208	153
CUNI.23.108.088	108	88.9	298	140

Slip Coupling Socket - Socket

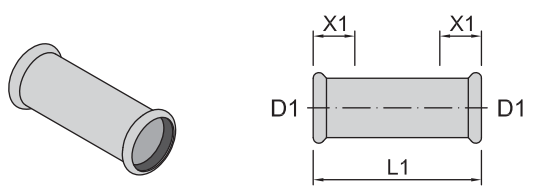

Material: CuNiFe (2.1972.11).

Ring Seal: NBR x2 supplied.

Product No	D1	L1	X1
CUNI.22.015	15	80	20
CUNI.22.018	18	80	21
CUNI.22.022	22	84	21
CUNI.22.028	28	92	24
CUNI.22.035	35	102	27
CUNI.22.042	42	120	32
CUNI.22.054	54	139	38
CUNI.22.076	76.1	226	55
CUNI.22.088	88.9	255	64
CUNI.22.108	108	304	78



■ 90 Bend Socket - Socket

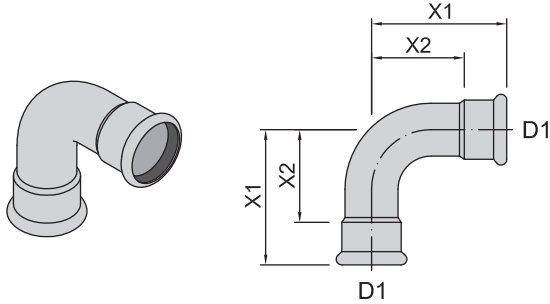

Material: CuNiFe (2.1972.11). Ring Seal: NBR x2 supplied.

Product No	D1	X1	X2
CUNI.31.090.015	15	36	56
CUNI.31.090.018	18	40	61
CUNI.31.090.022	22	51	72
CUNI.31.090.028	28	59	83
CUNI.31.090.035	35	97	124
CUNI.31.090.042	42	123	155
CUNI.31.090.054	54	129	167
CUNI.31.090.076	76.1	184	239
CUNI.31.090.088	88.9	212	276
CUNI.31.090.108	108	263	341

■ 90 Bend Socket - Tube End

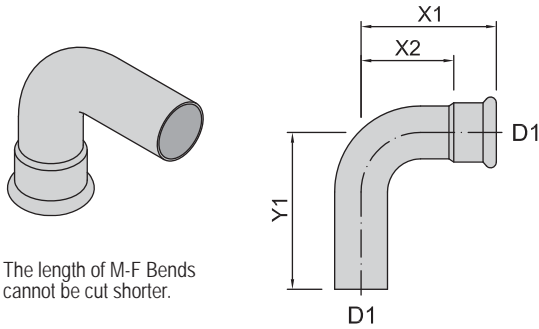

The length of M-F Bends cannot be cut shorter.

Material: CuNiFe (2.1972.11). Ring Seal: NBR x1 supplied.

Product No	D1	X1	X2	Y1
CUNI.32.090.015	15	36	36	62
CUNI.32.090.018	18	40	40	62
CUNI.32.090.022	22	51	51	77
CUNI.32.090.028	28	59	59	79
CUNI.32.090.035	35	97	93	127
CUNI.32.090.042	42	123	127	161
CUNI.32.090.054	54	129	129	173
CUNI.32.090.076	76.1	184	184	246
CUNI.32.090.088	88.9	212	212	284
CUNI.32.090.108	108	263	263	350

■ 45 Bend Socket - Socket

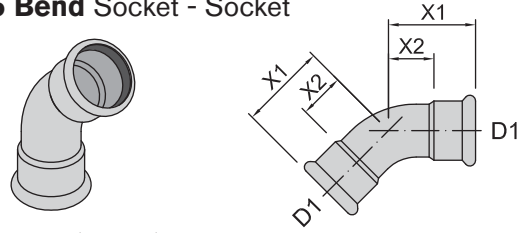

Material: CuNiFe (2.1972.11). Ring Seal: NBR x2 supplied.

Product No	D1	X1	X2
CUNI.31.045.015	15	38	18
CUNI.31.045.022	22	45	24
CUNI.31.045.028	28	52	28
CUNI.31.045.035	35	75	48
CUNI.31.045.042	42	88	56
CUNI.31.045.054	54	115	77
CUNI.31.045.076	76.1	186	131
CUNI.31.045.088	88.9	211	147
CUNI.31.045.108	108	247	169

■ 45 Bend Socket - Tube End

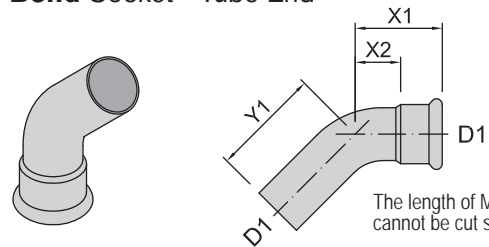

The length of M-F Bends cannot be cut shorter.

Material: CuNiFe (2.1972.11). Ring Seal: NBR x1 supplied.

Product No	D1	X1	X2	Y1
CUNI.32.045.015	15	38	18	48
CUNI.32.045.022	22	45	34	60
CUNI.32.045.028	28	52	31	62
CUNI.32.045.035	35	75	48	79
CUNI.32.045.042	42	88	56	93
CUNI.32.045.054	54	115	77	121
CUNI.32.045.076	76.1	186	131	194
CUNI.32.045.088	88.9	211	147	220
CUNI.32.045.108	108	247	169	256



■ Tee Equal Socket Ends & Branch

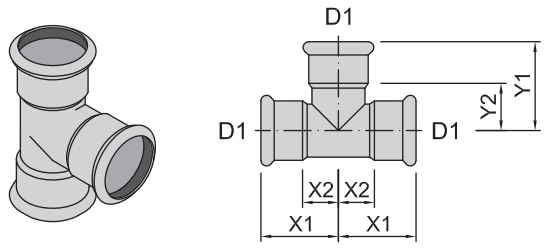

Material: CuNiFe (2.1972.11). Ring Seal: NBR x3 supplied.

Product No	D1	X1	X2	Y1
CUNI.51.015	15	38	18	39
CUNI.51.018	18	41	20	41
CUNI.51.022	22	44	23	44
CUNI.51.028	28	50	26	50
CUNI.51.035	35	56.5	29.5	56.5
CUNI.51.042	42	66	34	66
CUNI.51.054	54	79	41	79
CUNI.51.076	76.1	116.5	61.5	118
CUNI.51.088	88.9	128	64	128
CUNI.51.108	108	154.5	76.5	154.5

■ Tee Reduced Socket Ends & Branch

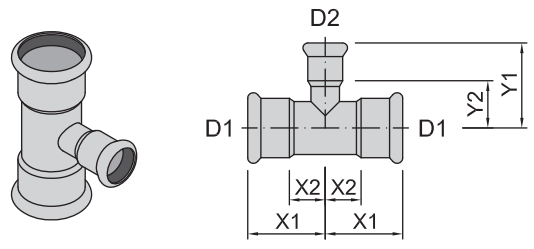

Material: CuNiFe (2.1972.11). Ring Seal: NBR x3 supplied.

Product No	D1	D2	X1	X2	Y1	Y2
CUNI.52.022.015	22	15	40	19	42.2	22
CUNI.52.028.015	28	15	40	20	45.2	25
CUNI.52.028.022	28	22	44	20	47.2	26
CUNI.52.035.015	35	15	52	25	47.5	27.5
CUNI.52.035.022	35	22	52	25	49.5	28.5
CUNI.52.035.028	35	28	52	25	52.5	28.5
CUNI.52.042.022	42	22	57	25	53	32
CUNI.52.042.028	42	28	57	25	56	32
CUNI.52.042.035	42	35	57	25	60	33
CUNI.52.054.022	54	22	54	34	60	39
CUNI.52.054.028	54	28	72	34	63	39
CUNI.52.054.035	54	35	72	34	67	40
CUNI.52.054.042	54	42	72	34	73	41
CUNI.52.076.022*	76.1	22	87	66	71	50
CUNI.52.076.028*	76.1	28	90	66	74	50
CUNI.52.076.035*	76.1	35	93	66	78	51
CUNI.52.076.042*	76.1	42	98	66	84	52
CUNI.52.076.054*	76.1	54	111	66	90	52
CUNI.52.088.022*	88.9	22	82	61	78	57
CUNI.52.088.028*	88.9	28	85	61	81	57
CUNI.52.088.035*	88.9	35	88	61	85	58
CUNI.52.088.042*	88.9	42	93	61	91	59
CUNI.52.088.054*	88.9	54	99	61	97	59
CUNI.52.088.076*	88.9	76.1	116	61	123.5	68.5
CUNI.52.108.022*	108	22	156	77	87	66
CUNI.52.108.028*	108	28	156	77	90	66
CUNI.52.108.035*	108	35	156	77	94	67
CUNI.52.108.042*	108	42	156	77	100	68
CUNI.52.108.054*	108	54	156	77	106	68
CUNI.52.108.076*	108	76.1	156	77	132.5	77.5
CUNI.52.108.088*	108	88.9	156	77	137.5	73.5

■ FI Tee Socket Ends & FI (Rp) Branch

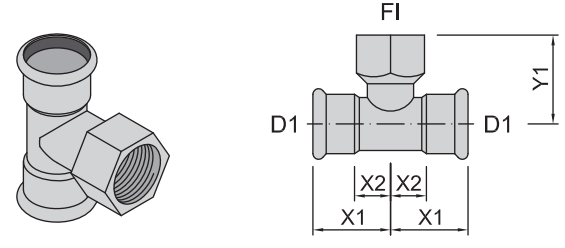

Material: CuNiFe (2.1972.11). Ring Seal: NBR x2 supplied.

Product No	D1	FI (Rp)	BSP	X1	X2	Y1
CUNI.53.015.015	15	1/2"		32.5	12.5	35.4
CUNI.53.022.015	22	1/2"		40	19	39.2
CUNI.53.022.020	22	3/4"		40	19	42.2
CUNI.53.028.015	28	1/2"		44	20	42.2
CUNI.53.028.020	28	3/4"		44	22	45.2
CUNI.53.035.015	35	1/2"		52.5	25.5	44.5
CUNI.53.035.020	35	3/4"		52.5	25.5	47.5
CUNI.53.042.015	42	1/2"		57	25	48
CUNI.53.042.020	42	3/4"		57	25	51
CUNI.53.054.015	54	1/2"		72	34	55
CUNI.53.054.020	54	3/4"		72	34	58
CUNI.53.076.015	76.1	1/2"		121	66	69
CUNI.53.076.020	76.1	3/4"		121	66	69
CUNI.53.088.015	88.9	1/2"		125	61	76
CUNI.53.088.020	88.9	3/4"		125	61	76
CUNI.53.108.015	108	1/2"		155	77	85
CUNI.53.108.020	108	3/4"		155	77	85

■ FI Adaptor Socket - FI (Rp) Thread

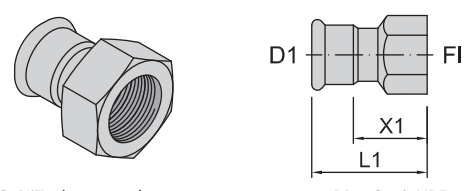

Material: CuNiFe (2.1972.11). Ring Seal: NBR x1 supplied.

Product No	D1	FI (Rp)	BSP	L1	X1
CUNI.73.015.015	15	1/2"		78	58
CUNI.73.022.015	22	1/2"		83	61
CUNI.73.022.020	22	3/4"		83	61
CUNI.73.028.025	28	1"		91	67
CUNI.73.035.032	35	1.1/4"		98	71
CUNI.73.042.040	42	1.1/2"		108	76
CUNI.73.054.050	54	2"		130	92

MI Adaptor Socket - MI (R) Thread

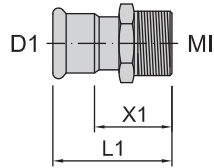
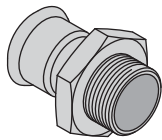

Material: CuNiFe (2.1972.11).

Ring Seal: NBR x1 supplied.

Product No	D1	MI	L1	X1	Thread
CUNI.74.015.015	15	1/2"	83	63	BSP
CUNI.74.022.015	22	1/2"	88	66	BSP
CUNI.74.022.020	22	3/4"	88	66	BSP
CUNI.74.028.025	28	1"	98	74	BSP
CUNI.74.035.032	35	1.1/4"	106	79	BSP
CUNI.74.042.040	42	1.1/2"	117	85	BSP
CUNI.74.054.050	54	2"	139	101	BSP

Product No	D1	MI	L1	X1	Thread
CUNI.74.015.015N	15	1/2"	83	63	NPT
CUNI.74.022.015N	22	1/2"	88	66	NPT
CUNI.74.022.020N	22	3/4"	88	66	NPT
CUNI.74.028.025N	28	1"	98	74	NPT
CUNI.74.035.032N	35	1.1/4"	106	79	NPT
CUNI.74.042.040N	42	1.1/2"	117	85	NPT
CUNI.74.054.050N	54	2"	139	101	NPT

Ring Seals

Fittings with a press-fit socket are fitted with a NBR rubber ring seal as standard.

Depending on the media, this ring seal can be changed to a different rubber material to suit the application.

Refer to our relevant Technical Media Chart for suitability and contact us for more information.

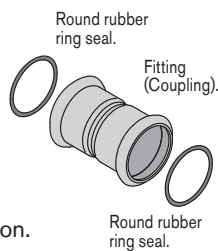

MI Union Socket - MI (R) BSP

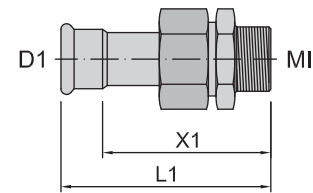
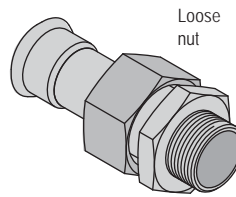

Material: CuNiFe (2.1972.11).

Ring Seal: NBR x1 supplied.
Gasket Seal: NBR x1 supplied.

Product No	D1	MI (R) BSP	L1	X1	Gasket Size
CUNI.82.015.015	15	1/2"	81	61	A1
CUNI.82.022.015	22	1/2"	84	63	B1
CUNI.82.022.020	22	3/4"	85	64	B1
CUNI.82.028.025	28	1"	96	73	C1
CUNI.82.035.032	35	1.1/4"	104	78	D1
CUNI.82.042.040	42	1.1/2"	109	79	E1
CUNI.82.054.050	54	2"	124	89	F1

Note: MI (R) Union is not suitable for gas or steam applications.

Union fittings are fitted with a (flat) rubber gasket seal and a (round) ring seal, both NBR as standard.

Depending on the media, **both seals** should be changed to a different rubber material to suit the application.

The gasket seal should be replaced when the union fitting is separated and before re-tightening the loose nut. Dispose of the used gasket.

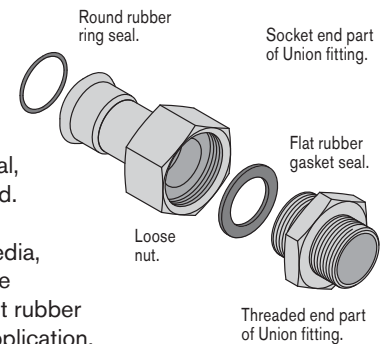

Refer to our Technical Data Sheets for ring seal suitability and resistance.

Flanged Stub End for a Loose Flange

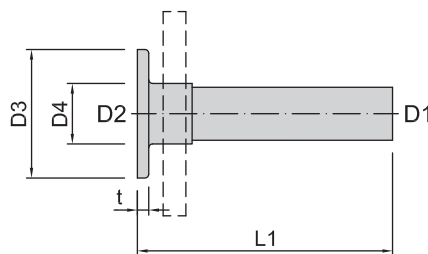
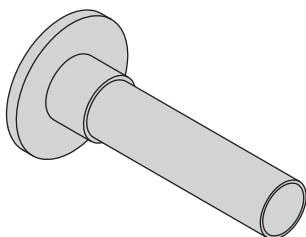

Material: CuNiFe (2.1972.11).

Flange: EN1092-1DN

Product No	D1	FL	D2	D3	D4	L1	t
CUNI.87.022.PN16	22	PN 16	27	58	27	135	6
CUNI.87.028.PN16	28	PN 16	32	68	32	135	6
CUNI.87.035.PN16	35	PN 16	40	78	40	135	6
CUNI.87.042.PN16	42	PN 16	46.5	88	46.5	135	6
CUNI.87.054.PN16	54	PN 16	59	102	59	135	8
CUNI.87.076.PN16	76.1	PN 16	78	122	78	135	8
CUNI.87.088.PN16	88.9	PN 16	91	138	91	135	10
CUNI.87.108.PN16	108	PN 16	110	158	110	135	10

Note: Loose flange, gasket, nuts & bolts not included.