

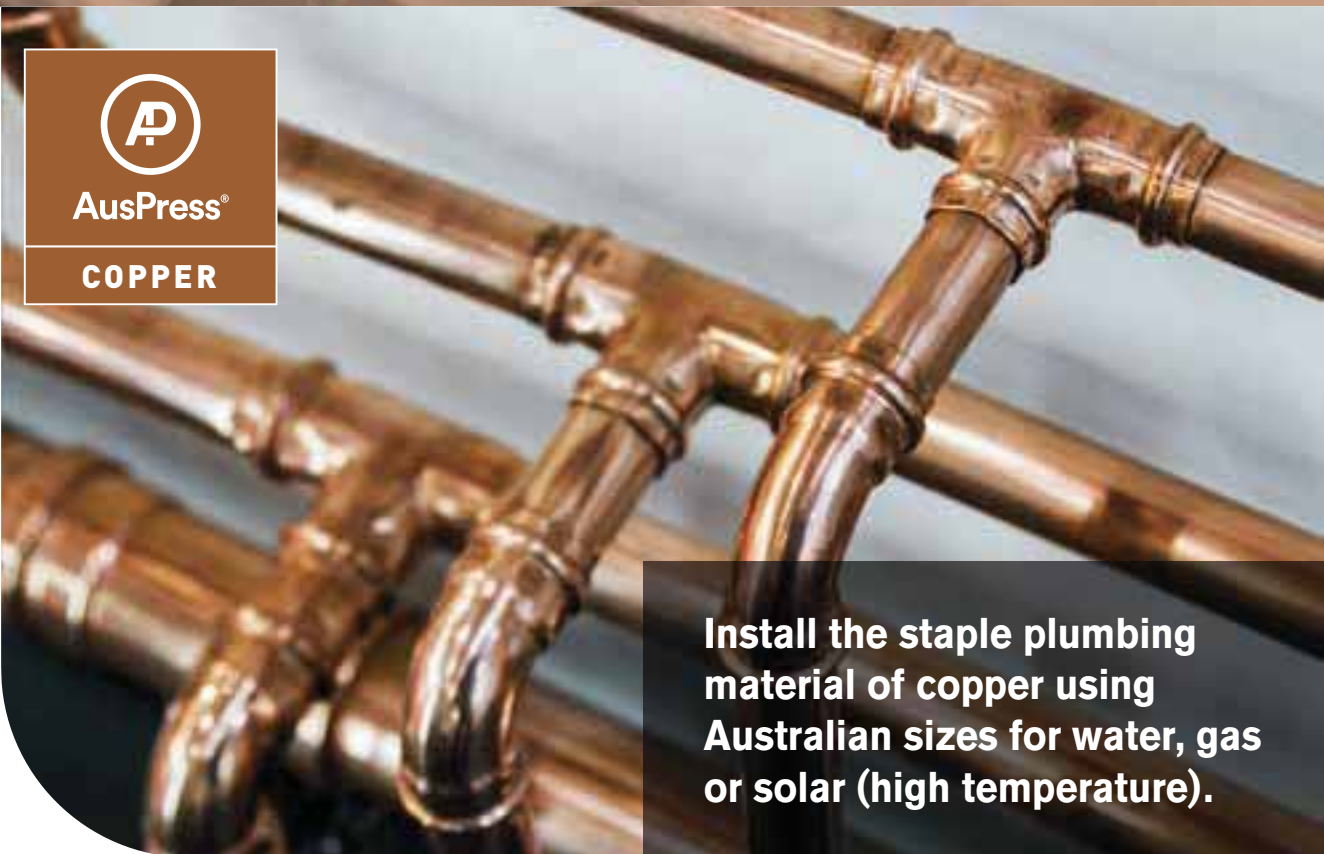

AusPress®

COPPER



Install the staple plumbing material of copper using Australian sizes for water, gas or solar (high temperature).



profile



DN15 to 100

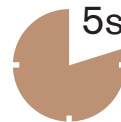

Press a DN25 fitting onto copper tube in under 5 seconds. Join done.

Faster to Install

AusPress press-fit offers large time savings compared to soldering, threading, grooving or glueing.

Quality to Install

Approved for water and gas applications to Australian & International standards.

Safer to Use

- One button tool operation.
- Lightweight battery tools.
- No flames or hot work permits.
- No heavy gas tanks.
- No hazardous fumes.
- Less risk - no waiting.

Reliable Design

- Suits a wide range of applications.
- Permanent high strength with the **'V' press** join profile.
- Consistent low profile join look & quality each time.

Experience Counts

We were the first to supply press-fit stainless in Australia & New Zealand.

We work with consultants & installers on specialised complex projects regularly.

Environmental Choice

- Long service life.
- Closed loop material (completely recycled to make more copper).
- Efficient and waste free install.

Installing AusPress®



DN15 to 50

Start to install quicker...

AusPress Copper is installed easily using a Press Tool to form a permanent join. Installation only by a licensed plumber to AS 3500.



Start here

Check for suitability...

Both copper material and the rubber ring seal shall be checked for suitability for the application and environmental conditions.

This product complies with the requirements of Lead-Free standards as defined in the National Construction Code Volume 3 and is suitable for use as part of a Lead-Free (LF) installation.

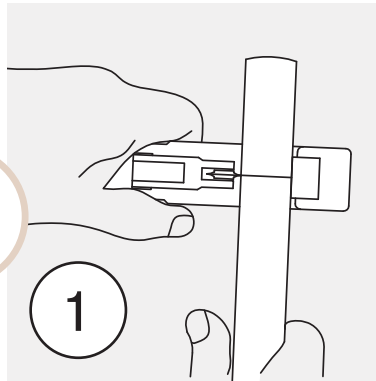

Cut to Length

Cut the tube at right angles using a tube cutter or fine tooth saw.

Note: Using the same cutting tool on different metals can lead to corrosion.

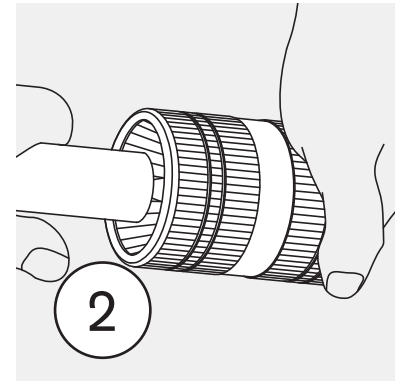

Deburr Tube

Deburr both inside & outside edges of tube to prevent damage to the ring seal of the fitting.

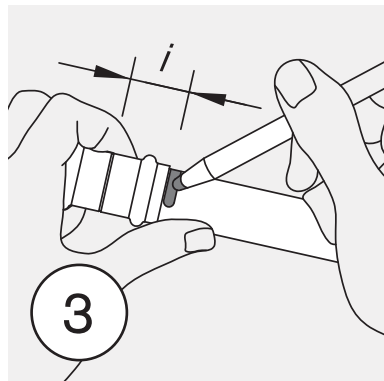

Mark the Insertion Depth "i"

Measure or use a depth gauge to mark the insertion depth (socket depth) onto the tube end.

This is a visual quality control mark to ensure the tube is fully inserted.

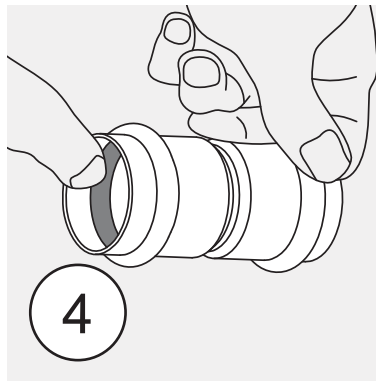

Inspect Fitting & Ring Seals

Check that the rubber ring seal is:

- The correct material type (colour) of seal is used.
- The seal is not damaged.
- Both fitting & seal are free of debris.

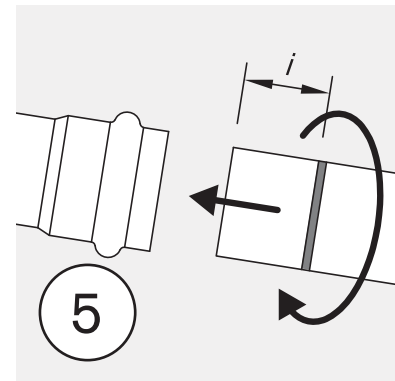

Join the Tube & Fitting

Insert the tube into the fitting press socket, turning slightly until it reaches the previously marked insertion depth.

Soapy water can be used if joining is difficult.



Press the Join

Using a suitable press tool and V-profile jaw or collar, align the press jaw with the fitting and join following the tool manufacturer's instructions.

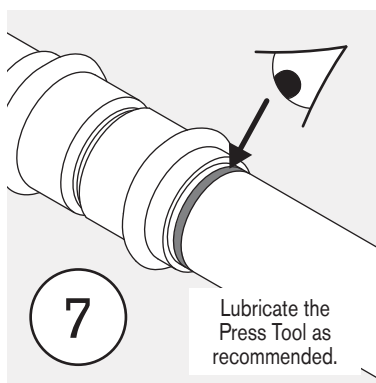

Check the Press

Visually inspect the pressed fitting & that the insertion mark is aligned with the end of the socket.

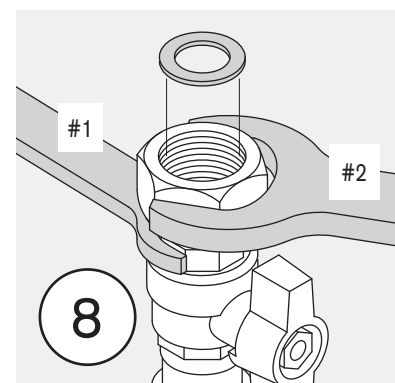

Threaded Ends

Tighten threads with the fitting supported, don't tighten against a pressed joint alone.



Installing AusPress®



DN DN65 to 100

Start to install quicker...

AusPress Copper is installed easily using a Press Tool to form a permanent join. Installation only by a licensed plumber to AS 3500.



Start here

Check for suitability...

Both copper material and the rubber ring seal shall be checked for suitability for the application and environmental conditions.

This product complies with the requirements of Lead-Free standards as defined in the National Construction Code Volume 3 and is suitable for use as part of a Lead-Free (LF) installation.

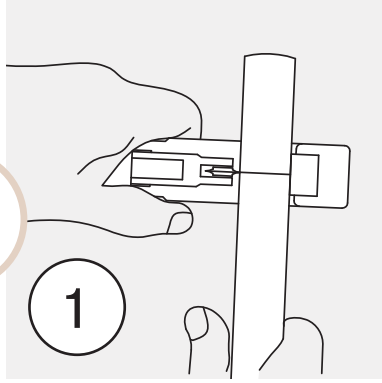

Cut to Length

Cut the tube at right angles using a tube cutter or fine tooth saw.

Note: Using the same cutting tool on different metals can lead to corrosion.

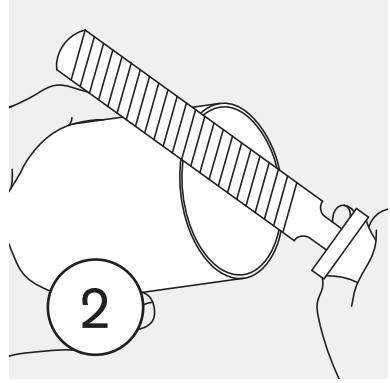

Deburr Tube

Deburr both inside & outside edges of tube to prevent damage to the ring seal of the fitting.

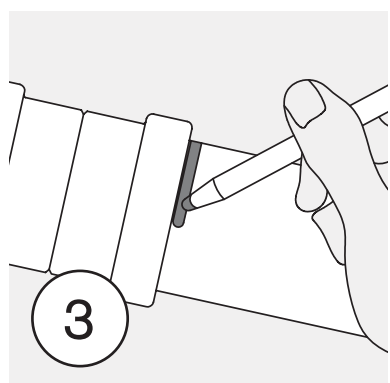

Mark the Insertion Depth "l"

Measure or use a depth gauge to mark the insertion depth (socket depth) onto the tube end.

This is a visual quality control mark to ensure the tube is fully inserted.

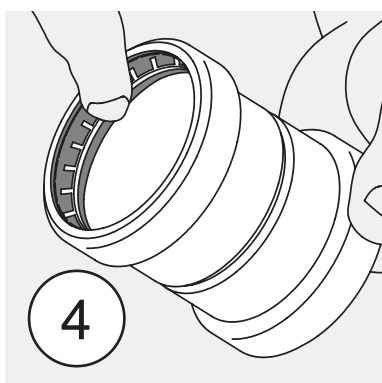

Inspect Fitting & Ring Seals

Check that the socket end has:

- The correct material type (colour) of ring seal is used.
- The parts are not damaged.
- The fitting, grab ring & seal are free of debris.

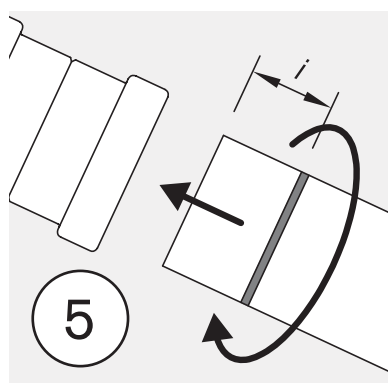

Join the Tube & Fitting

Insert the tube into the fitting press socket, turning slightly until it reaches the previously marked insertion depth.

Soapy water can be used if joining is difficult.

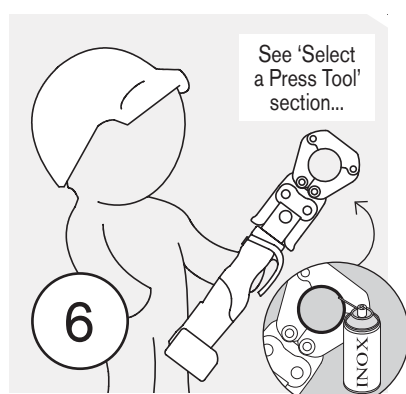

Press Tool Selection

Select the correct press tool, jaw or collar to suit the fitting, dimension and application pressures. Ensure press zone is lubricated each press with Inox spray.

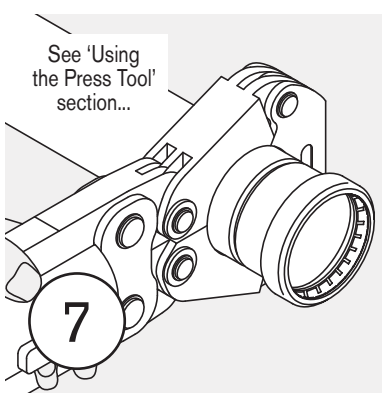

Press the Join

Align the press jaw or collar with the press socket and start the press to join the fitting & tube.

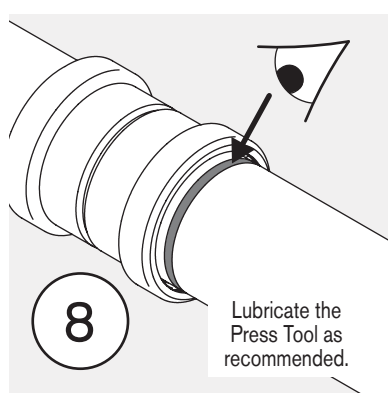

Check & Complete

Visually inspect the pressed fitting & that the insertion mark is aligned with the end of the socket.

Select a Type & Press Tool

Read with 'Using the Press Tools' section.

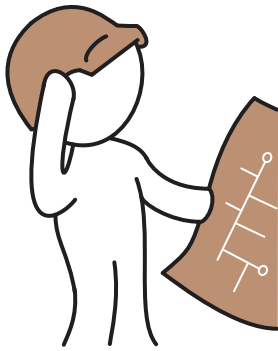

Let's Start...
Our range of Copper Press Fittings are supplied with a different ring seal pre-fitted depending on the application - Water, Solar (High Temp) or Gas.

Start here

AusPress Copper

We supply a complete range of press tools & press jaws for copper, stainless steel, PEX and multi-layer systems too.

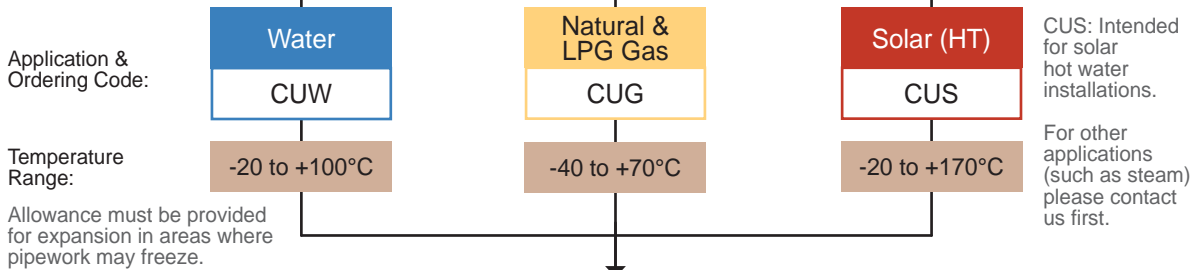

Max Working Pressure*: 1,600 kPa 16 bar 232 psi
Subject to applicable approval and regulation maximum pressures (eg Natural Gas up to 2 bar for AS 5601).

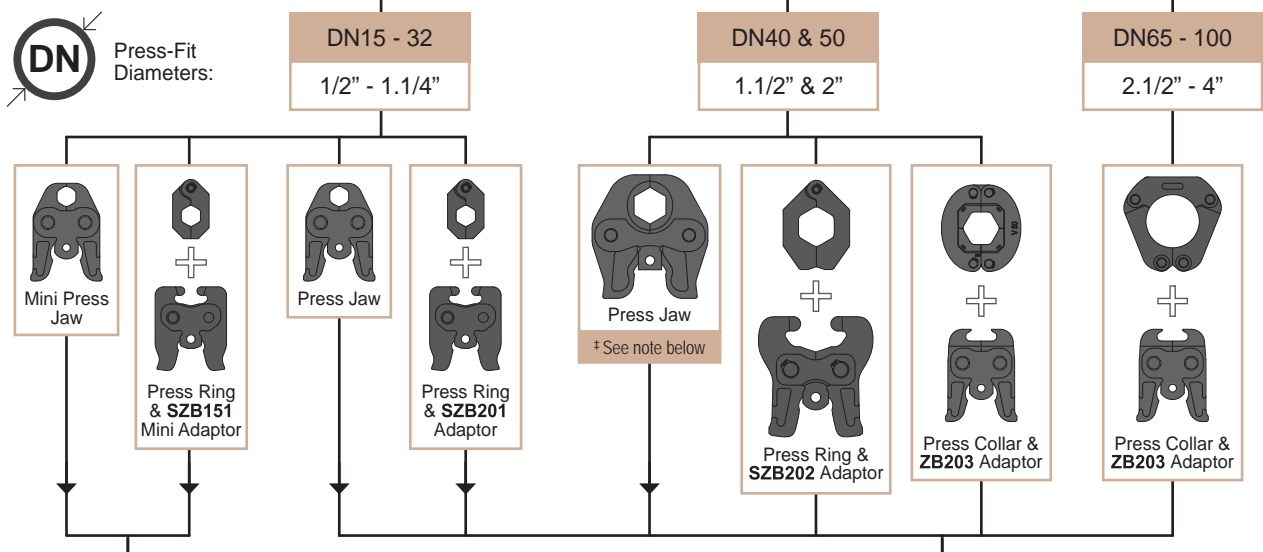

SPM24 24kN

ACO153 24kN

Other brand tools:

- Kembla KPS
- Viega Pressgun Picco
- Novopress ACO152
- Milwaukee M12 Force Logic

‡ Note: Confirm the suitability of the various branded DN40 & DN50 Jaws with V-Profile Copper fittings before commencing work.

Ensure the inner press surfaces are lubricated with Innox for a smooth consistent press.
Reapply as needed.

ACO203 32kN
6 sec press

ACO203-XL 32kN

Plus...

- Vetec CPN700
- Novopress AFP202
- R'berger Romax 3000
- Viega Pressgun 4B
- Viega Pressgun 5
- Rems Akku-Press
- Kembla KPL ‡
- Kembla KPLx ‡
- Milwaukee M18 Force Logic
- Milwaukee M18 Force Logic Long Throw
- Klauke UAP3L
- Klauke UAP4L
- Rems Akku-Press
- Rems Akku-Press XL

Please Note:
This chart is a guide and full specifications and instructions are available on request. Confirm with tool manufacturers for compatibility as their specifications may be changed.

* This value is the maximum working pressure, not the safety or testing pressure of the system.



Copper Tube Type A

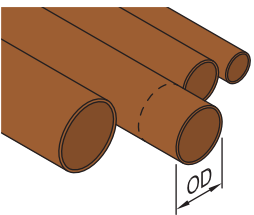

AusPress Copper Fittings are compatible with copper tube complying with AS1432, Type A or B.

Fittings are from Type A.

Hard drawn tubes are recommended. Annealed tube must be true round, inserted straight and square into the fitting.

i = insertion depth. Tube must be inserted into the press socket a minimum distance to ensure the join is pressed successfully.

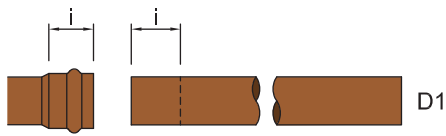

D1 (DN)	OD (mm)	i depth	Type A t	Type B t
15	12.70	19	1.02	0.91
18	15.88	21	1.22	1.02
20	19.05	22	1.42	1.02
25	25.40	23	1.63	1.22
32	31.75	26	1.63	1.22
40	38.10	32	1.63	1.22
50	50.80	40	1.63	1.22
65	63.50	42	1.63	1.22
80	76.20	48	2.03	1.63
100	101.60	60	2.03	1.63

Ring Seals



Water
Colour: Black
Material: EPDM
Range: -20°C to +100°C



Gas
Colour: Yellow
Material: NBR
Range: -40°C to +70°C

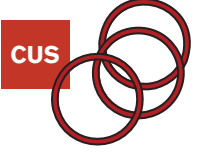

Solar (High Temp)
Colour: Red
Material: FKM (Viton)
Range: -20°C to +170°C

Each press-fit socket is pre-fitted with a rubber ring seal. Sizes 15 to 50 have the ring seal alone, larger sizes have the ring seal and a stainless steel grab ring as part of the socket end.

Ring seals are not interchangeable - for example you cannot swap a water ring seal for a gas ring seal.

Refer to our relevant Technical Media Chart for suitability or contact us for more information.

Press-Fit Installation Plate

CAUTION

This system uses AusPress press fittings. When brazing or welding, protect all press fittings from heat transfer and ensure minimum setback clearances are observed from press fittings. More information: www.auspress.com.au

Product No	Colour: Yellow	Pack Qty
AP.CTAG.1Y	90 x 55mm	1x
AP.CTAG.10Y	90 x 55mm	10x

As required by some authorities for gas and other installations using press-fit connections.

Fitting Installation Clearances

Confirm sizes and clearance distances before installing and also refer to the tool installation clearances.

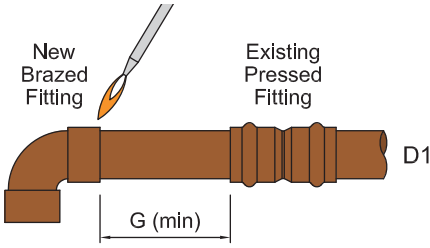
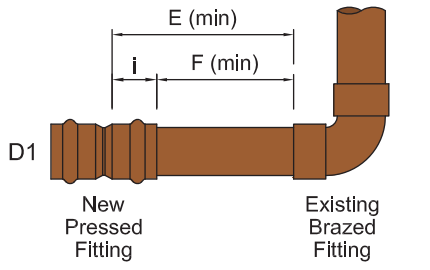

We recommend to wrap the closest existing press join fitting(s) with a wet cloth while brazing.

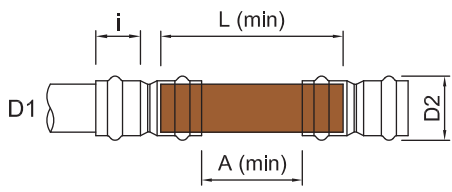

For specific information, please contact us.

D1	Profile	i	L	A	D2	E	F	G
15	V	19	51	13	20	32	13	1000
18	V	21	55	13	24	34	13	1000
20	V	22	57	13	27	35	13	1000
25	V	23	61	15	34	38	15	1000
32	V	26	67	15	41	41	15	1000
40	V	32	84	20	49	52	20	1000
50	V	40	105	25	61	65	25	1300
65	V	42	109	25	79	67	25	1600
80	V	48	126	30	90	78	30	2000
100	V	60	150	30	116	90	30	2500

V-Profile fittings shown (eg DN15 - 50), AusPress Copper sizes over DN50 are measured from the end of the fitting.

Measurements are dependant on the actual fitting dimensions and the Press Tool used to join. Confirm clearances with your particular installation as these may change.

■ Coupling Socket - Socket

Material: Copper, Type A.

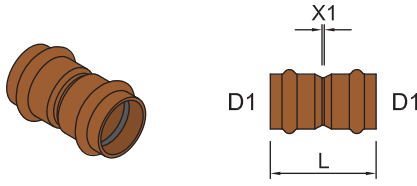

Solar (HT) Also available: DN15, 20 & 25.

D1	L	X1	Water	Gas	Bag Qty
			Ring Seal: EPDM x2	Ring Seal: HNBR x2	
15	40	2	CUW.21.015	CUG.21.015	10x
20	48	4	CUW.21.020	CUG.21.020	10x
25	51	5	CUW.21.025	CUG.21.025	5x
32	54	2	CUW.21.032	CUG.21.032	5x
40	67	3	CUW.21.040	CUG.21.040	2x
50	83	3	CUW.21.050	CUG.21.050	2x
65	113	29	CUW.21.065	CUG.21.065	-
80	122	26	CUW.21.080	CUG.21.080	-
100	143	23	CUW.21.100	CUG.21.100	-

■ Slip (Repair) Coupling Socket - Socket

Material: Copper, Type A.

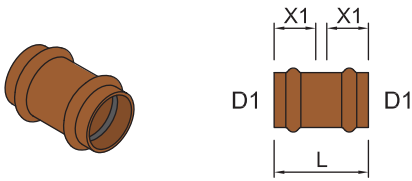

Note: No stopper - ensure tube reaches the insertion depth X1.

D1	L	X1	Water	Gas	Bag Qty
			Ring Seal: EPDM x2	Ring Seal: HNBR x2	
15	40	19	CUW.22.015	CUG.22.015	10x
20	48	22	CUW.22.020	CUG.22.020	10x
25	51	23	CUW.22.025	CUG.22.025	5x
32	54	26	CUW.22.032	CUG.22.032	5x
40	67	32	CUW.22.040	CUG.22.040	2x
50	83	40	CUW.22.050	CUG.22.050	2x
65	111	42	CUW.22.065	CUG.22.065	-
80	123	48	CUW.22.080	CUG.22.080	-
100	138	60	CUW.22.100	CUG.22.100	-

■ 45 Bend Socket - Socket

Material: Copper, Type A.

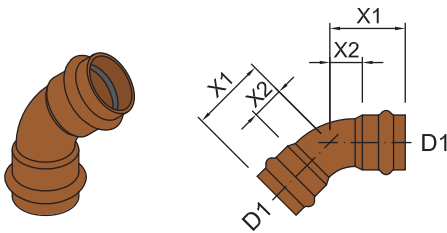

D1	X1	X2	Water	Gas	Bag Qty
			Ring Seal: EPDM x2	Ring Seal: HNBR x2	
15	32	13	CUW.31.045.015	-	10x
20	29	7	CUW.31.045.020	CUG.31.045.020	5x
25	34	11	CUW.31.045.025	CUG.31.045.025	5x
32	41	15	CUW.31.045.032	CUG.31.045.032	5x
40	51	19	CUW.31.045.040	CUG.31.045.040	2x
50	64	24	CUW.31.045.050	CUG.31.045.050	2x
65	80	38	CUW.31.045.065	CUG.31.045.065	-
80	85	37	CUW.31.045.080	CUG.31.045.080	-
100	114	54	CUW.31.045.100	CUG.31.045.100	-

■ 90 Bend Socket - Socket

Material: Copper, Type A.

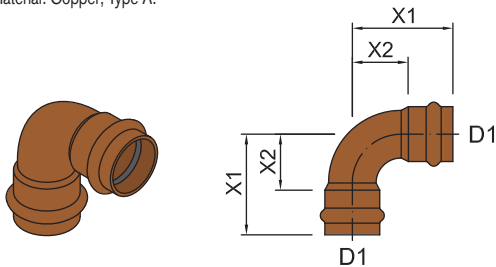

Solar (HT) Also available: DN15, 20 & 25.

D1	X1	X2	Water	Gas	Bag Qty
			Ring Seal: EPDM x2	Ring Seal: HNBR x2	
15	33	14	CUW.31.090.015	CUG.31.090.015	10x
20	36	14	CUW.31.090.020	CUG.31.090.020	10x
25	45	22	CUW.31.090.025	CUG.31.090.025	5x
32	52	26	CUW.31.090.032	CUG.31.090.032	5x
40	76	44	CUW.31.090.040	CUG.31.090.040	2x
50	92	52	CUW.31.090.050	CUG.31.090.050	2x
65	110	68	CUW.31.090.065	CUG.31.090.065	-
80	135	87	CUW.31.090.080	CUG.31.090.080	-
100	187	127	CUW.31.090.100	CUG.31.090.100	-

■ 45 Bend Tube End - Socket

Material: Copper, Type A.

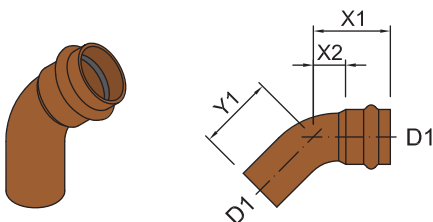

D1	X1	X2	Y1	Water	Gas	Bag Qty
				Ring Seal: EPDM x1	-	
25	34	11	34	CUW.32.045.025	-	5x
32	41	15	41	CUW.32.045.032	-	5x
40	51	19	51	CUW.32.045.040	-	2x
50	64	24	64	CUW.32.045.050	-	2x



90 Bend Tube End - Socket

Material: Copper, Type A.

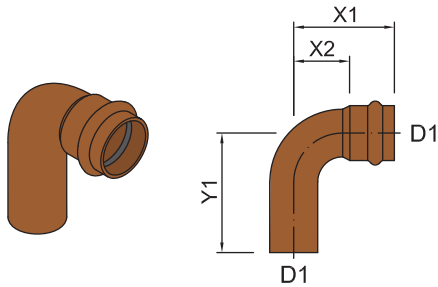

D1	X1	X2	Y1	Water	Gas	Bag Qty
				Ring Seal: EPDM x1	Ring Seal: HNBR x1	
15	33	14	34	CUW. 32.090.015	CUG. 32.090.015	5x
20	36	14	46	CUW. 32.090.020	CUG. 32.090.020	5x
25	45	22	51	CUW. 32.090.025	CUG. 32.090.025	5x
32	52	26	45	CUW. 32.090.032	CUG. 32.090.032	5x
40	76	44	71	CUW. 32.090.040	CUG. 32.090.040	2x
50	92	52	93	CUW. 32.090.050	CUG. 32.090.050	2x
65	110	68	126	CUW. 32.090.065	-	-
80	135	87	147	CUW. 32.090.080	-	-
100	187	127	176	CUW. 32.090.100	-	-

Socket Reducer Socket - Socket

Material: Copper, Type A.
Material: Brass*

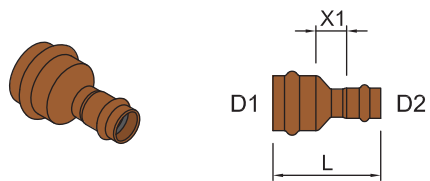

Solar (HT) Also available: DN20x15.
DN25x15.
DN25x20.

D1	D2	L	X1	Water	Gas	Bag Qty
				Ring Seal: EPDM x2	Ring Seal: HNBR x2	
18	15	44	4	CUW. 29.018.015*	-	10x
20	15	52	11	CUW. 29.020.015	CUG. 29.020.015	10x
20	18	47	4	CUW. 29.020.018*	-	10x
25	15	54	12	CUW. 29.025.015	CUG. 29.025.015	5x
25	20	55	10	CUW. 29.025.020	CUG. 29.025.020	5x
32	20	61	13	CUW. 29.032.020	CUG. 29.032.020	5x
32	25	57	8	CUW. 29.032.025	CUG. 29.032.025	5x
40	20	73	19	CUW. 29.040.020	CUG. 29.040.020	2x
40	25	69	14	CUW. 29.040.025	CUG. 29.040.025	2x
40	32	69	11	CUW. 29.040.032	CUG. 29.040.032	2x
50	20	91	29	CUW. 29.050.020	CUG. 29.050.020	2x
50	25	87	24	CUW. 29.050.025	CUG. 29.050.025	2x
50	32	84	18	CUW. 29.050.032	CUG. 29.050.032	2x
50	40	86	14	CUW. 29.050.040	CUG. 29.050.040	2x
65	32	94	26	CUW. 29.065.032	CUG. 29.065.032	-
65	40	99	25	CUW. 29.065.040	CUG. 29.065.040	-
65	50	104	22	CUW. 29.065.050	CUG. 29.065.050	-
80	40	110	30	CUW. 29.080.040	CUG. 29.080.040	-
80	50	110	22	CUW. 29.080.050	CUG. 29.080.050	-
80	65	114	24	CUW. 29.080.065	CUG. 29.080.065	-
100	50	132	32	CUW. 29.100.050	CUG. 29.100.050	-
100	65	131	29	CUW. 29.100.065	CUG. 29.100.065	-
100	80	131	23	CUW. 29.100.080	CUG. 29.100.080	-

Spigot Reducer Tube End - Socket

Material: Copper, Type A.

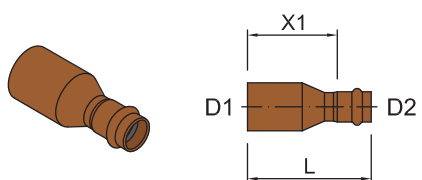

D1	D2	L	X1	Water	Gas	Bag Qty
				Ring Seal: EPDM x1	Ring Seal: HNBR x1	
20	15	50	31	CUW. 23.020.015	CUG. 23.020.015	10x
25	15	65	46	CUW. 23.025.015	CUG. 23.025.015	10x
25	20	53	31	CUW. 23.025.020	CUG. 23.025.020	5x
32	20	60	38	CUW. 23.032.020	CUG. 23.032.020	5x
32	25	56	33	CUW. 23.032.025	CUG. 23.032.025	5x
40	25	70	47	CUW. 23.040.025	CUG. 23.040.025	5x
40	32	67	41	CUW. 23.040.032	CUG. 23.040.032	5x
50	25	85	62	CUW. 23.050.025	-	5x
50	32	83	57	CUW. 23.050.032	CUG. 23.050.032	5x
50	40	87	55	CUW. 23.050.040	CUG. 23.050.040	5x
65	40	113	81	CUW. 23.065.040	-	-
65	50	107	67	CUW. 23.065.050	CUG. 23.065.050	-
80	40	133	101	CUW. 23.080.040	-	-
80	50	128	88	CUW. 23.080.050	CUG. 23.080.050	-
80	65	125	83	CUW. 23.080.065	CUG. 23.080.065	-
100	50	154	114	CUW. 23.100.050	CUG. 23.100.050	-
100	65	152	110	CUW. 23.100.065	CUG. 23.100.065	-
100	80	147	99	CUW. 23.100.080	CUG. 23.100.080	-



■ Tee Equal Socket x3

Material: Type A Copper.

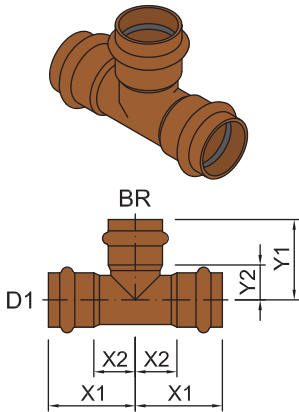

D1	BR	D1	X1	X2	Y1	Y2	Water	Gas	Bag Qty
							Ring Seal: EPDM x3	Ring Seal: HNBR x3	
15	15	15	33	14	29	10	CUW.51.015	CUG.51.015	10x
20	20	20	43	21	36	14	CUW.51.020	CUG.51.020	10x
25	25	25	46	23	44	21	CUW.51.025	CUG.51.025	5x
32	32	32	55	29	48	22	CUW.51.032	CUG.51.032	5x
40	40	40	60	28	58	26	CUW.51.040	CUG.51.040	2x
50	50	50	73	33	75	35	CUW.51.050	CUG.51.050	2x
65	65	65	93	51	92	50	CUW.51.065	CUG.51.065	-
80	80	80	102	54	103	55	CUW.51.080	CUG.51.080	-
100	100	100	125	65	125	65	CUW.51.100	CUG.51.100	-

Solar (HT) Also available: DN15, 20 & 25.

■ Tee Reduced Socket - Branch - Socket

Material: Type A Copper.

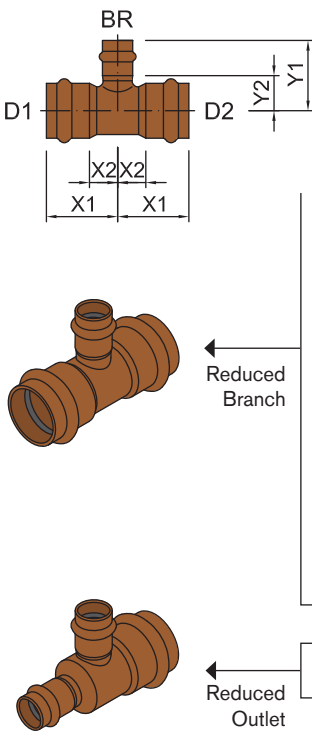

D1	BR	D2	X1	X2	Y1	Y2	Water	Gas	Bag Qty
							Ring Seal: EPDM x3	Ring Seal: HNBR x3	
20	15	20	38	16	32	13	CUW.52.020.015.020	CUG.52.020.015.020	10x
25	15	25	40	17	35	16	CUW.52.025.015.025	CUG.52.025.015.025	5x
25	20	25	43	20	40	18	CUW.52.025.020.025	CUG.52.025.020.025	5x
32	15	32	37	11	38	19	CUW.52.032.015.032	-	5x
32	20	32	37	11	42	20	CUW.52.032.020.032	-	5x
32	25	32	43	17	44	21	CUW.52.032.025.032	CUG.52.032.025.032	5x
40	20	40	49	17	50	28	CUW.52.040.020.040	-	2x
40	25	40	50	18	50	27	CUW.52.040.025.040	-	2x
40	32	40	56	24	51	25	CUW.52.040.032.040	CUG.52.040.032.040	2x
50	20	50	58	18	54	32	CUW.52.050.020.050	-	2x
50	25	50	61	21	56	33	CUW.52.050.025.050	-	2x
50	32	50	61	21	59	33	CUW.52.050.032.050	-	2x
50	40	50	68	28	66	34	CUW.52.050.040.050	CUG.52.050.040.050	2x
65	50	65	78	36	84	44	CUW.52.065.050.065	CUG.52.065.050.065	-
80	50	80	90	42	90	50	CUW.52.080.050.080	-	-
80	65	80	96	48	100	58	CUW.52.080.065.080	CUG.52.080.065.080	-
100	50	100	101	41	104	64	CUW.52.100.050.100	-	-
100	65	100	107	47	118	76	CUW.52.100.065.100	-	-
100	80	100	114	54	125	77	CUW.52.100.080.100	CUG.52.100.080.100	-
20	15	15			32	13	CUW.52.020.015.015	CUG.52.020.015.015	10x
20	20	15			36	14	CUW.52.020.020.015	CUG.52.020.020.015	10x

■ End Cap Socket End

Material: Copper, Type A.

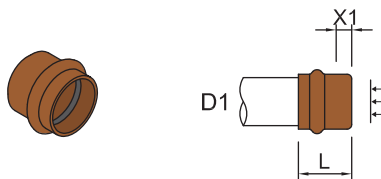

These End Caps are supplied with F1 (Rp) BSP 3/4" nut at end (add 26mm to 'L' length).

D1	L	X1	Water	Gas	Bag Qty
			Ring Seal: EPDM x1	Ring Seal: HNBR x1	
15	21	2	CUW.24.015	CUG.24.015	10x
20	26	4	CUW.24.020	CUG.24.020	10x
25	28	5	CUW.24.025	CUG.24.025	5x
32	30	4	CUW.24.032	CUG.24.032	5x
40	36	4	CUW.24.040	CUG.24.040	2x
50	47	7	CUW.24.050	CUG.24.050	-
65	52	10	CUW.24.065	CUG.24.065	-
80	57	9	CUW.24.080	CUG.24.080	-
100	66	6	CUW.24.100	CUG.24.100	-



■ **MI Union Socket - MI (R) BSP**

Material: Brass.

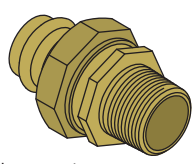

Loose nut.

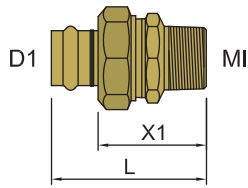

D1	MI	L	X1	Water	Gas	Bag Qty
				Ring Seal: EPDM x1	Ring Seal: HNBR x1	
15	1/2"	59	40	CUW.82.015.015	CUG.82.015.015	10x
20	3/4"	69	47	CUW.82.020.020	CUG.82.020.020	10x
25	1"	78	55	CUW.82.025.025	CUG.82.025.025	5x
32	1.1/4"	83	57	CUW.82.032.032	CUG.82.032.032	1x
40	1.1/2"	93	61	CUW.82.040.040	CUG.82.040.040	1x
50	2"	113	73	CUW.82.050.050	CUG.82.050.050	1x

■ **90 FI Bend Wall Fix Socket - FI (Rp) BSP**

Material: Brass.

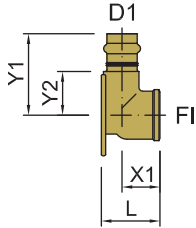
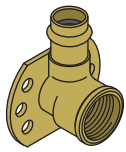

D1	FI	L	X1	Y1	Y2	Water	Gas	Bag Qty
						Ring Seal: EPDM x1	Ring Seal: HNBR x1	
15	1/2"	39	26	35	16	CUW.36.015.015	CUG.36.015.015	5x
20	3/4"	47	30	42	20	CUW.36.020.020	CUG.36.020.020	5x

■ **90 MI Bend Wall Fix Socket - BSP-P**

Material: Brass.

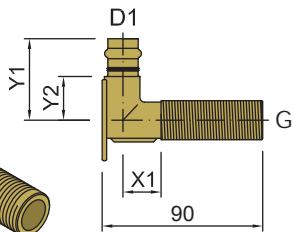
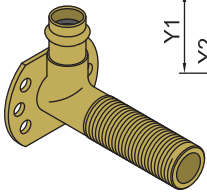

D1	G	X1	Y1	Y2	Water	Gas	Bag Qty
					Ring Seal: EPDM x1	Ring Seal: HNBR x1	
15	1/2"	15	36	17	CUW.37.015.015	CUG.37.015.015	5x
20	1/2"	28	35	13	CUW.37.020.015	CUG.37.020.015	5x
20	3/4"	35	43	21	CUW.37.020.020	CUG.37.020.020	5x

Fitting may not be suitable for refer flammable gasses - AS5601.1

■ **90 FI Bend Socket - FI (Rp) BSP**

Material: Brass.

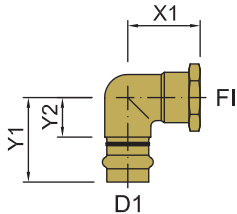
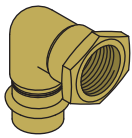

D1	FI	X1	Y1	Y2	Water	Gas	Bag Qty
					Ring Seal: EPDM x1	Ring Seal: HNBR x1	
15	1/2"	27	34	15	CUW.34.015.015	CUG.34.015.015	10x
20	3/4"	30	42	20	CUW.34.020.020	CUG.34.020.020	5x
25	3/4"	33	44	21	CUW.34.025.020	CUG.34.025.020	5x
25	1"	36	47	24	CUW.34.025.025	CUG.34.025.025	5x

■ **90 MI Bend Socket - MI (R) BSP**

Material: Brass.

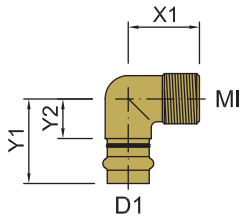
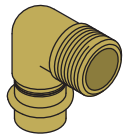

D1	MI	X1	Y1	Y2	Water	Gas	Bag Qty
					Ring Seal: EPDM x1	Ring Seal: HNBR x1	
15	1/2"	27	34	15	CUW.35.015.015	CUG.35.015.015	10x
20	3/4"	31	42	20	CUW.35.020.020	CUG.35.020.020	10x
25	1"	40	46	23	CUW.35.025.025	CUG.35.025.025	5x



MI Adaptor Socket - MI (R) BSP

Material: Brass.

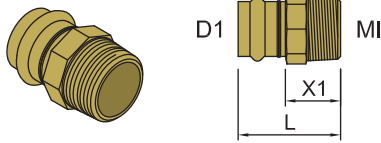

Solar (HT) Also available: DN15, 20 & 25.

D1	MI	L	X1	Water	Gas	Bag Qty
				Ring Seal: EPDM x1	Ring Seal: HNBR x1	
15	1/2"	43	24	CUW.74.015.015	CUG.74.015.015	10x
20	1/2"	47	25	CUW.74.020.015	CUG.74.020.015	5x
20	3/4"	48	26	CUW.74.020.020	CUG.74.020.020	5x
25	3/4"	51	28	CUW.74.025.020	CUG.74.025.020	5x
25	1"	55	32	CUW.74.025.025	CUG.74.025.025	5x
32	1.1/4"	57	31	CUW.74.032.032	CUG.74.032.032	1x
40	1.1/2"	65	33	CUW.74.040.040	CUG.74.040.040	1x
50	2"	79	39	CUW.74.050.050	CUG.74.050.050	1x

FI Adaptor Socket - FI (Rp) BSP

Material: Brass.

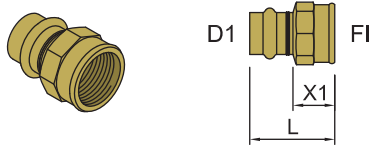

Solar (HT) Also available: DN15 & 20.

D1	FI	L	X1	Water	Gas	Bag Qty
				Ring Seal: EPDM x1	Ring Seal: HNBR x1	
15	1/2"	41	22	CUW.73.015.015	CUG.73.015.015	10x
20	3/4"	46	24	CUW.73.020.020	CUG.73.020.020	5x
25	1"	50	27	CUW.73.025.025	CUG.73.025.025	5x
32	1.1/4"	54	28	CUW.73.032.032	CUG.73.032.032	5x
40	1.1/2"	61	29	CUW.73.040.040	CUG.73.040.040	1x
50	2"	74	34	CUW.73.050.050	CUG.73.050.050	1x

FI Adaptor Socket - FI (G) BSP Loose Nut

Material: Brass.

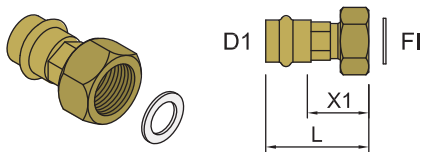

D1	FI	L	X1	Water	Bag Qty
				Ring Seal: EPDM x1	
20	3/4"	54	32	CUW.44.020.020	5x
25	1"	57	34	CUW.44.025.025	5x

Flat gasket included.

Adaptor PEX: Slide Socket - PEX (PN20)

Material: Brass.



D1	PEX	L	X1	Water	Bag Qty
				Ring Seal: EPDM x1	
15	16	48	29	CUW.67.015.016	5x
20	20	56	34	CUW.67.020.020	5x

Sleeve not included.
 Confirm PEX system suitability before installation.
 PEX pipe: PEX-A PN20 16mm (16.3x2.2-2.6)
 PEX-A PN20 20mm (20.3x2.8-3.2)

Adaptor PEX-Al: Crimp Socket - PEX Multilayer (PN20)

Material: Brass, EPDM seals on barb with Stainless Sleeve.

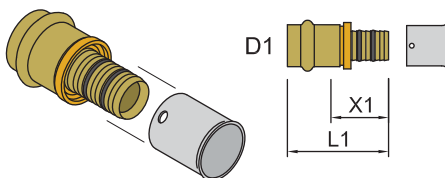

D1	PEX	L	X1	Water	Gas	Bag Qty
				Ring Seal: EPDM x1	Ring Seal: HNBR x1	
15	16	50	31	CUW.66.015.016	CUG.66.015.016	10x
20	20	55	33	CUW.66.020.020	CUG.66.020.020	10x
25	25	65	42	CUW.66.025.025	CUG.66.025.025	5x
32	32	66	40	CUW.66.032.032	CUG.66.032.032	5x

Sleeve included.
 U-Profile jaw for PEX crimping. Confirm PEX system suitability before installation.
 PEX Pipe: PEX-AL PN20 16mm (16x2.2)
 PEX-AL PN20 20mm (20x2.8)
 PEX-AL PN20 25mm (25x3.5)
 PEX-AL PN20 32mm (32x4.4)



Ball Valve Socket - Socket

Material: Brass body.

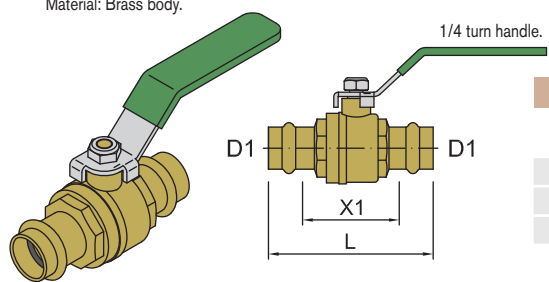

D1	D1	L	X1	Max: 1,050kPa		Bag Qty
				Water	Gas	
				Ring Seal: EPDM x1 Handle Colour: Green	Ring Seal: HNBR x1 Handle Colour: Yellow	
15	15	71	33	CUW. 46 .015.015	CUG. 43 .015.015	x10
20	20	87	43	CUW. 46 .020.020	CUG. 43 .020.020	x8
25	25	100	54	CUW. 46 .025.025	CUG. 43 .025.025	x5

Ball Valve Socket - FI (Rp) Fixed Nut

Material: Brass body.

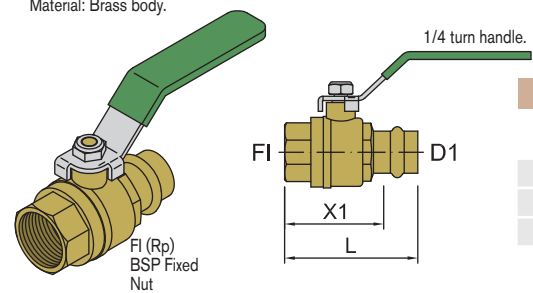

D1	FI	L	X1	Max: 1,050kPa		Bag Qty
				Water	Gas	
				Ring Seal: EPDM x1 Handle Colour: Green	Ring Seal: HNBR x1 Handle Colour: Yellow	
15	1/2"	61	42	CUW. 45 .015.015	CUG. 41 .015.015	x10
20	3/4"	70	48	CUW. 45 .020.020	CUG. 41 .020.020	x8
25	1"	88	65	CUW. 45 .025.025	CUG. 41 .025.025	x5

Flanged Tube Stub Tube End - Slip On Flange

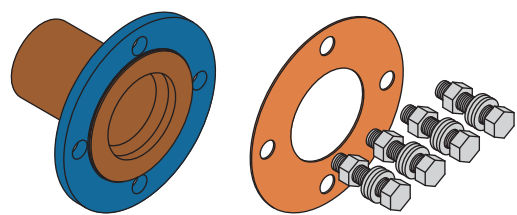

Painted Flange & Copper Stub Bolt & Flat Face Gasket Kit

Length	D1	Flange	KPa	Flange & Stub	Bolt & Gasket Kit	PCB	OB Holes
					FKM gasket material galv bolt / nut		
87	40	Tab-E	1,400	CUF. E .040	CUF. GBKE .040	98	14x4
94	50	Tab-E	1,400	CUF. E .050	CUF. GBKE .050	114	18x4
151	65	Tab-E	1,400	CUF. E .065	CUF. GBKE .065	127	18x4
151	80	Tab-E	1,400	CUF. E .080	CUF. GBKE .080	146	18x4
153	100	Tab-E	1,400	CUF. E .100	CUF. GBKE .100	178	18x8

Bolt & gasket kits sold separately from the flange product code. These items available on request and other flange types also available. AS2129-2000 -Max 1,400 kPa; 2100 kPa test pressure.

High Temperature Range Pre-fitted FKM ring seal fittings

These fittings are pre-fitted with a 'High Temperature' or 'Solar' ring seal intended for hot water service pipework. For other applications (such as steam) please consult with us first.

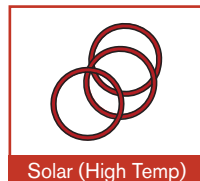

Solar (High Temp)
Material: FKM (Viton)
Red
-20°C to +170°C

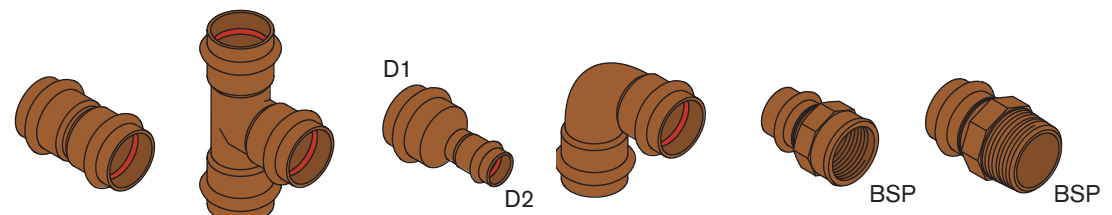

D1	BSP	D2	Solar (HT)	Solar (HT)	Solar (HT)	Solar (HT)	Solar (HT)	Solar (HT)
			Ring Seal: FKM x2	Ring Seal: FKM x3	Ring Seal: FKM x2	Ring Seal: FKM x2	Ring Seal: FKM x1	Ring Seal: FKM x1
15	-	-	CUS. 21 .015	CUS. 51 .015	-	CUS. 31 .090.015	-	-
20	-	-	CUS. 21 .020	CUS. 51 .020	-	CUS. 31 .090.020	-	-
25	-	-	CUS. 21 .025	CUS. 51 .025	-	CUS. 31 .090.025	-	-
20	-	15	-	-	CUS. 29 .020.015	-	-	-
25	-	15	-	-	CUS. 29 .025.015	-	-	-
25	-	20	-	-	CUS. 29 .025.020	-	-	-
15	1/2"	-	-	-	-	-	CUS. 73 .015.015	CUS. 74 .015.015
20	3/4"	-	-	-	-	-	CUS. 73 .020.020	CUS. 74 .020.020
25	1"	-	-	-	-	-	CUS. 73 .025.025	CUS. 74 .025.025

Tech Data Sheet: AusPress Copper Press-Fit



V-Profile System



Water, Gas & Solar



Aus Sizes DN15 - 100

What is Press-Fit?

A quick, flame free and consistent process using a press tool fitted with matching profiled jaw or collar to form a permanent and consistent joint between tube and fitting.

Applications:

Common applications include:

- Potable, Chilled and Hot Water.
- Compressed Air.
- Chemical lines.
- Fire services (subject to AS 2419.1).
- Fuels & Oils (excluding Diesel).
- Gases - Inert & Flammable.
- Steam (wet) to 100°C.
- Vacuum.
- Not suitable for sewer or stormwater.
- Other applications on request.

Refer to our Media Chart, Technical Catalogue or contact us directly for specific information and suitability.

Key Features

- Very fast installation process.
- No need for hot-work permits.
- Simple process to train users to install using a press tool.
- One system suits a wide range of applications.
- Fittings stocked in Australia.
- Large range of fitting types including flanged adaptors and threaded fittings.
- Long service life and recyclable product (closed reuse loop).
- Efficient and waste free install.

FAQ:

- Deburr the tube inside and out to prevent damage to the ring seal is best practice.
- Ensure minimum distance between pressed fittings is observed.
- Protect press fittings from the transferred heat of brazing new fittings.
- Chemicals? Ask us to confirm suitability for stainless and ring seal.
- Expansion? Calcs available.

Copper Tube

- Type A and Type B copper tube manufactured to AS 1432 is suitable to use with our fittings.
- Hard drawn tube is recommended; annealed tube to be used straight and true round before pressing.
- Chromed tube? Ok (if to AS 1432) but some splitting of the plating may occur at the press area.

Tube DN	Tube OD	Thickness	
		A	B
15	12.70	1.02	0.91
18	15.88	1.22	1.02
20	19.05	1.42	1.02
25	24.50	1.63	1.22
32	31.75	1.63	1.22
40	38.10	1.63	1.22
50	50.80	1.63	1.22
65	63.50	1.63	1.22
80	76.20	2.03	1.63
100	101.60	2.03	1.63

Press Fittings

- Type A copper.
- DZR brass (selected fittings).
- Australian sizing **DN15 to 100**.
- **V-Profile** socket (with ring seal, diameters 65+ ring seal and stainless steel grab ring).
- Ring seal pre-fitted to socket ends.
- Markings – laser etched.

Ring Seals (Elastomers)

- Pre-fitted, not to be interchanged.
- Contain no softening agents or other fillers which lead to embrittlement.
- Pre-lubricated seals from the manufacturer, don't use oil or spray.
- Water seals feature "leak before press" detection; identifies unpressed joints between 100-500kPa up to 54mm diameter.
- Slow aging process.
- Maintain a low compression set value, even at higher temps.
- Low oxygen permeation rate; this is critical in avoiding corrosion effects due to the intrusion of oxygen.

Seal Type*	Temp Range
Water	-20 to +100°C
Gas	-40 to +70°C
Solar (HT)	-20 to +170°C

*Refer to our Media Chart & contact us for suitability before installation.

Pressure Ratings:

The maximum working pressure depends on the application being used. Contact AusPress for specific chemical or application consideration.

Working pressures (kPa)*:		
Tube DN	Potable Water 85°C	Natural Gas
15 to 100	1,600	200

* Figures noted are maximum. Natural Gas limit per AS 5601. Higher pressures on request.

Pressure test to AS 3500 or AS 5601 as applicable. Generally, test potable water services to 1.5x the working pressure.

Tooling

- The jaw/collar profile must match the fitting profile: V-Profile on V-Profile.
- Lubricate the jaw & collar 'press zone' regularly with Inox spray.
- Most press tools are recognised by AusPress as suitable including Romax 4000, Viega Pressgun and Novopress tools – ask for suitability.

Warranty

- 50 year design life, standard 25 year product warranty – refer to our Tech Note TN.06 for details.

System Approvals & Compliance:

- WaterMark AS 3688
- WaterMark AS 5601.1

Technical Assistance

- Suitability checks for projects & applications on request.
- Tech Notes and Media Chart product reference material.
- AusPress staff available across Australia & New Zealand.

Need More Information?

Please contact us for product support, technical advice or your project specific requirements:

- Phone: 1300 287 773
- Email: sales@auspress.com.au

Visit auspress.com.au for the latest product information, tech notes & catalogues.