

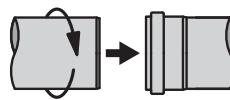

Diameters
110 to 630mm



Push to
Join



High
Temp
Suitable

Faster to Install

Push-together drainage systems offer superior installation times compared to welding, threading, grooving or glueing.

Quality to Install

- Approved to WaterMark and International standards.
- Lightweight to handle, install and support on site.
- Superior temperature tolerance compared to uPVC or HDPE.

Experience Counts

We've been working with consultants and installers on specialised solutions since 1992 with a focus on food processing, mining, commercial and industrial projects across Australia and New Zealand.

Stronger Design

- Engineered 'mineral modified' polypropylene (PP-MD) material to provide SN10 and SN16 class material strength.
- Extremely strong pipe and fittings with increased wall thickness.

Reliable Design

- 3-Lip Seal standard for fast installation and secure sealing.
- High abrasion resistant surface.
- Excellent chemical resistance.
- Suits a wide range of applications including sewer, storm water, trade waste and cable conduit.

Environmental Choice

- Long lifespan and service life.
- Closed loop material (may be completely recycled).

Installation Guide

Start to install drainage quicker...
With the polypropylene pipe and fittings designed with a socket & spigot, joining is simply pushing the fittings together.

Refer to the technical section for installation recommendations & more information.

Start here

Follow the flow rule...

Push together drainage is directional; the water flow must travel socket to spigot.

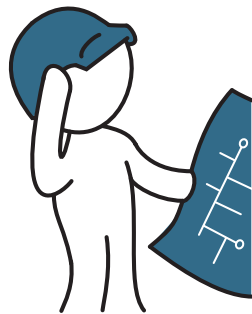
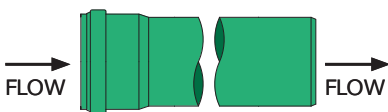

Check for suitability...

Confirm the material and the ring seal (eg SBR) are suitable for the application and situation. Some chemicals and environments can be unsuitable, please ask us if unsure.

Ring Seal Colours

SBR ring seals are supplied as standard unless ordered otherwise.

Colour	Material	Temperature*	
		Min	Max
Black	SBR	-20°C	90°C
Black	NBR	-20°C	90°C

* Maximum continuous temperatures. 110°C 1-5 mins/day.

For ring seal suitability with chemicals and other applications, please contact us for assessment.

This guide is only for standard applications.

For specific or specialised applications please contact us first - www.auspress.com.au

Ordering & Design

Drainage pipe is available in different lengths (from 500mm to 6m) so choose the length closest to what is needed to reduce offcut waste.

Cut Pipe to Length

Cutting to length is easy using a suitable fine tooth hand saw or plastic pipe cutter;
- Cut the pipe square (wrap-around tape & mark) or,
- Use a cutting guide frame/box for assistance.

Pipes are supplied with a socket and a spigot end; cut off from the spigot end keeping the socket. Using offcut spigot-spigot pipe pieces is not recommended.
Note fittings are not to be cut.

Bevel the Cut End

Each cut spigot requires the external edge to be bevelled to an angle of 15° to protect the ring seal and help to lead the pipe or fitting into the socket.:

- Use a bevelling tool or coarse file,
- Bevel the pipe to ~15° (refer table below).

D1	B
110	6
160	7
200	9
250	9
315	12
400	15
500	18
630	21

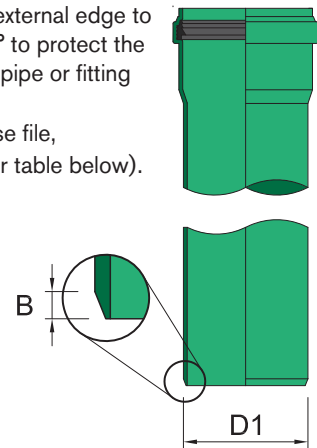

3

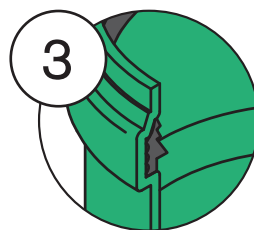

Inspect & Lubricate the Ring Seal

In the socket, check that the ring seal is:

- The correct material specified and,
- With the mitred edge facing inwards and,
- Not damaged and is free of debris.

Apply a small amount of joining lubricant to the ring seal inside the socket. We stock a silicon based lubricant.

Do not use oil or grease as a lubricant, this may damage the ring seal material.

4

Push, Twist & Pull

Using a slight twisting movement, push the spigot fully into the socket. Mark the full insertion depth with a texta on the spigot end of the pipe/fitting. Then, retract 10-12mm from the socket to allow for expansion & contraction to occur within each socket.

5

Limited UV Resistance

Due to its composition of materials, colourants and UV protective agents, KG2000 can be stored outdoors for 12 months post production without affecting the physical properties of the pipe. Fading of the pipe components due to outdoor storage does not affect the mechanical properties of pipes and fittings.



■ Pipe Length Socket - Spigot

Material: Polypropylene (PP-MD).
Ring Seal: SBR x1 fitted.

Each length of polypropylene drainage pipe is supplied with a socket (fitted with an SBR rubber ring seal) and tapered spigot end.

Available in two load classes, SN10 and SN16, the pipe is ordered in various lengths to reduce offcut wastage on site.

The system is directional;
the water flow must travel
from socket to spigot.

Confirm the material and ring seal are suitable for your application!

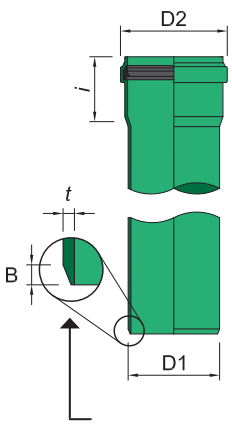

B = Bevel
After cutting square, bevel the spigot end of the pipe with an appropriate tool, forming a bevel ~15°.

D1	Insertion Depth <i>i</i>	B	SN10 rating		SN16 rating	
			t	D2	t	D2
110	78 - 68	6	3.4	129	4.2	131
160	100 - 90	7	4.9	187	6.2	190
200	120 - 110	9	6.2	236	7.7	239
250	123 - 133	9	7.7	288	9.6	292
315	150 - 140	12	9.7	359	12.1	364
400	195 - 185	15	12.3	455	15.3	461
500	170 - 160	18	15.3	565	19.1	573
630			19.3		24.1	

Retract 10mm after pushing together for expansion & contraction.

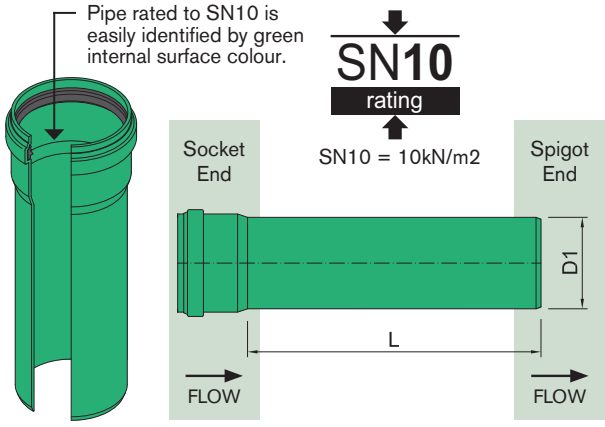

Product No	L	D1	Load Class	Weight (kg)	
				Dry	Wet †
KG.P10.0500.110	0.5m	110	SN10	1.0	5.2
KG.P10.1000.110	1m	110	SN10	1.8	10.2
KG.P10.2000.110	2m	110	SN10	3.4	20.1
KG.P10.5000.110	5m	110	SN10	8.2	50.0
KG.P10.0500.160	0.5m	160	SN10	2.2	11.0
KG.P10.1000.160	1m	160	SN10	3.7	21.4
KG.P10.2000.160	2m	160	SN10	6.7	42.1
KG.P10.5000.160	5m	160	SN10	16.1	104.7
KG.P10.0500.200	0.5m	200	SN10	3.5	17.4
KG.P10.1000.200	1m	200	SN10	5.9	33.6
KG.P10.2000.200	2m	200	SN10	11.2	66.5
KG.P10.5000.200	5m	200	SN10	26.7	164.9
KG.P10.0500.250	0.5m	250	SN10	3.5	17.4
KG.P10.1000.250	1m	250	SN10	5.9	33.6
KG.P10.2000.250	2m	250	SN10	11.2	66.5
KG.P10.5000.250	5m	250	SN10	26.7	164.9
KG.P10.1000.315	1m	315	SN10	9.3	52.6
KG.P10.3000.315	3m	315	SN10	25.0	154.7
KG.P10.6000.315	6m	315	SN10	48.7	308.0
KG.P10.1000.400	1m	400	SN10	15.2	83.8
KG.P10.3000.400	3m	400	SN10	39.8	245.7
KG.P10.6000.400	6m	400	SN10	76.7	488.5
KG.P10.1000.500	1m	500	SN10	26.8	137.5
KG.P10.3000.500	3m	500	SN10	67.2	399.3
KG.P10.6000.500	6m	500	SN10	126.3	790.4
KG.P10.1000.630	1m	630	SN10	44.7	217.7
KG.P10.3000.630	3m	630	SN10	110.2	629.3
KG.P10.6000.630	6m	630	SN10	205.7	1,244.0
KG.P10.1000.630	1m	630	SN10		
KG.P10.3000.630	3m	630	SN10		
KG.P10.6000.630	6m	630	SN10		

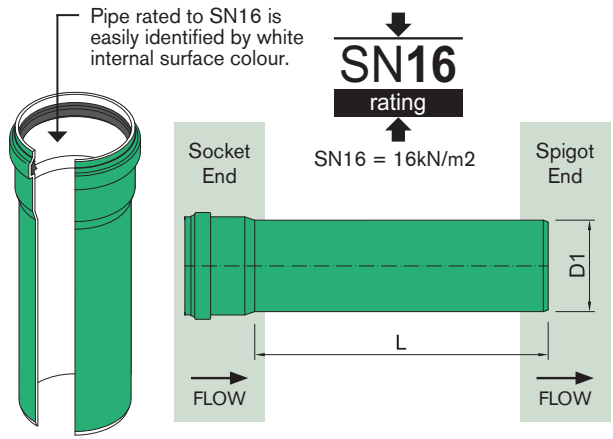

Product No	L	D1	Load Class	Weight (kg)	
				Dry	Wet †
KG.P16.1000.110	1m	110	SN16	1.8	9.9
KG.P16.3000.110	3m	110	SN16	4.9	29.2
KG.P16.6000.110	6m	110	SN16	9.8	58.4
KG.P16.1000.160	1m	160	SN16	3.7	20.8
KG.P16.3000.160	3m	160	SN16	9.7	61.0
KG.P16.6000.160	6m	160	SN16	19.4	122.1
KG.P16.1000.200	1m	200	SN16	5.9	32.7
KG.P16.3000.200	3m	200	SN16	16.5	96.8
KG.P16.6000.200	6m	200	SN16	33.0	193.6
KG.P16.1000.250	1m	250	SN16	9.3	51.2
KG.P16.3000.250	3m	250	SN16	25.0	150.5
KG.P16.6000.250	6m	250	SN16	48.7	299.7
KG.P16.1000.315	1m	315	SN16	15.2	81.6
KG.P16.3000.315	3m	315	SN16	39.8	239.0
KG.P16.6000.315	6m	315	SN16	76.7	475.2
KG.P16.1000.400	1m	400	SN16	26.8	134.0
KG.P16.3000.400	3m	400	SN16	67.2	388.7
KG.P16.6000.400	6m	400	SN16	126.3	769.3
KG.P16.1000.500	1m	500	SN16	44.7	212.2
KG.P16.3000.500	3m	500	SN16	110.2	612.7
KG.P16.6000.500	6m	500	SN16	205.7	1,210.6
KG.P16.1000.630	1m	630	SN16		
KG.P16.3000.630	3m	630	SN16		
KG.P16.6000.630	6m	630	SN16		

†Wet weights calculated using full volume filled with water.



Bend 87° Socket - Spigot

Material: Polypropylene (PP-MD).
Ring Seal: SBR x1 fitted.

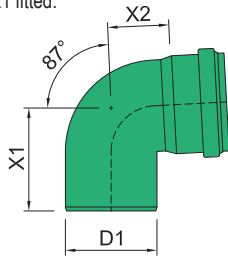

Product No	D1	X1	X2
KG.B.87.110	110	137	65
KG.B.87.160	160	180	91

Bend 67° Socket - Spigot

Material: Polypropylene (PP-MD).
Ring Seal: SBR x1 fitted.

Double bend arrangements shown for offset dimensions only - each bend sold separately.

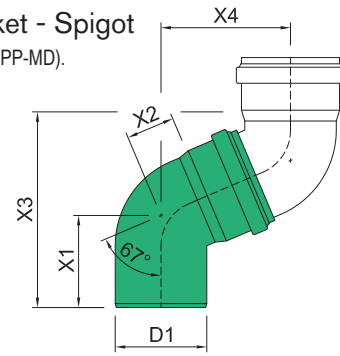

Product No	D1	X1	X2	X3	X4
KG.B.67.110	110	119	47	235	162
KG.B.67.160	160	161	69	324	221

Bend 45° Socket - Spigot

Material: Polypropylene (PP-MD).
Ring Seal: SBR x1 fitted.

Double bend arrangements shown for offset dimensions only - each bend sold separately.

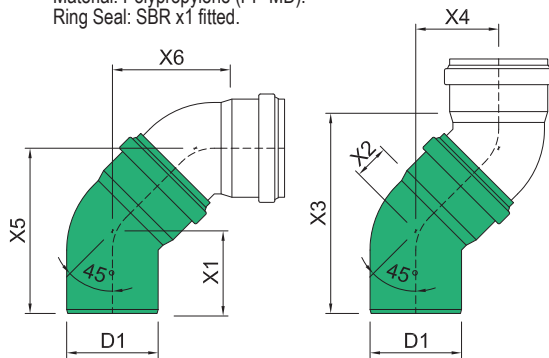

Product No	D1	X1	X2	X3	X4	X5	X6
KG.B.45.110	110	94	29	217	94	188	123
KG.B.45.160	160	144	45	330	141	285	186
KG.B.45.200	200	189	57	427	181	370	238
KG.B.45.250	250	199	77	478	202	401	279
KG.B.45.315	315	233	98	572	241	474	339
KG.B.45.400	400	283	120	695	292	575	412
KG.B.45.500	500	334	254	1,011	423	757	677
KG.B.45.630	630						

Bend 30° Socket - Spigot

Material: Polypropylene (PP-MD).
Ring Seal: SBR x1 fitted.

Double bend arrangements shown for offset dimensions only - each bend sold separately.

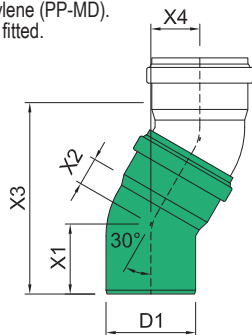

Product No	D1	X1	X2	X3	X4
KG.B.30.110	110	95	23	229	64
KG.B.30.160	160	125	34	305	85
KG.B.30.200	200	162	46	397	109
KG.B.30.250	250	297	217	968	262

Bend 15° Socket - Spigot

Material: Polypropylene (PP-MD).
Ring Seal: SBR x1 fitted.

Double bend arrangements shown for offset dimensions only - each bend sold separately.

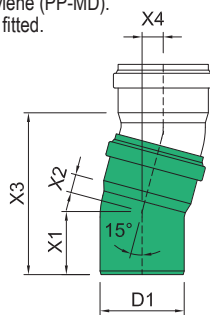

Product No	D1	X1	X2	X3	X4
KG.B.15.110	110	87	16	212	29
KG.B.15.160	160	120	19	283	39
KG.B.15.200	200	158	31	381	52
KG.B.15.250	250	163	44	417	56
KG.B.15.315	315	188	56	489	66
KG.B.15.400	400	220	67	574	77
KG.B.15.500	500	263	183	886	118
KG.B.15.630	630	263	183	886	118

Lubricant



Product No	Description
AP.Lube.250	Lubricant jointing paste 250mL
AP.Lube.500	Lubricant jointing paste 500mL
AP.Lube.1000	Lubricant jointing paste 1000mL



■ **Single Junction 45°**

Material: Polypropylene (PP-MD).
Ring Seal: SBR x2 fitted.

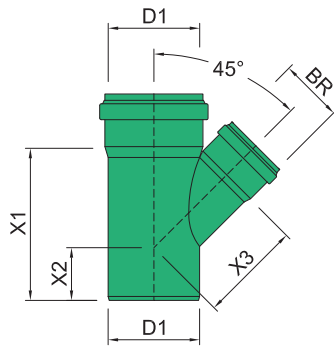

Product No	D1	BR	X1	X2	X3
KG.J.45.110	110	110	228	94	134
KG.J.45.160	160	160	320	125	195
KG.J.45.200	200	200	433	189	244
KG.J.45.250	250	250	500	189	311
KG.J.45.315	315	315	617	224	393
KG.J.45.400	400	400	914	231	683
KG.RJ.45.160.110	160	110	250	88	168
KG.RJ.45.200.160	200	160	380	162	221
KG.RJ.45.250.160	250	160	500	189	258
KG.RJ.45.315.160	315	160	442	192	301
KG.RJ.45.315.200	315	200	617	224	325
KG.RJ.45.400.160	400	160	544	18	394
KG.RJ.45.400.200	400	200	601	46	417
KG.RJ.45.400.315	400	315			
KG.RJ.45.500.160	500	160	610	80	490
KG.RJ.45.500.315	500	315			
KG.RJ.45.630.160	630	160			
KG.RJ.45.630.200	630	200			

■ **Single Junction 87°**

Material: Polypropylene (PP-MD).
Ring Seal: SBR x2 fitted.

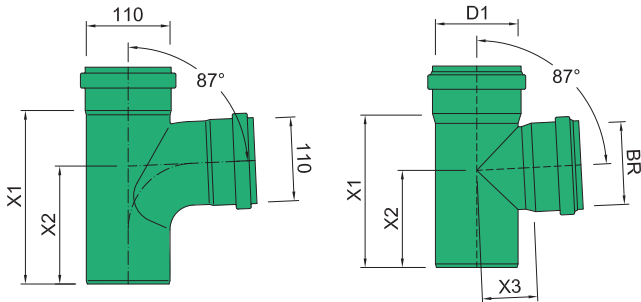

Product No	D1	BR	X1	X2	X3
KG.J.87.110	110	110	197	133	64
KG.J.87.160	160	160	279	188	91
KG.RJ.87.160.110	160	110	227	87	141

■ **Increaser Eccentric Socket > Spigot**

Material: Polypropylene (PP-MD).
Ring Seal: SBR x1 fitted (D1).

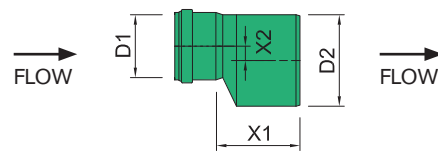

Product No	D1 → D2	X1	X2
KG.IE.160.110	110 160	135	25
KG.IE.200.160	160 200	175	20
KG.IE.250.200	250 200	181	25
KG.IE.315.250	250 315	215	33
KG.IE.400.315	315 400	271	43
KG.IE.500.400	400 500	312	50
KG.IE.630.500	500 630		

■ **Double Socket with Centre Stopper**

Material: Polypropylene (PP-MD).
Ring Seal: SBR x2 fitted.

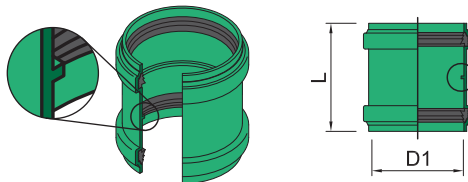

Product No	D1	L
KG.DS.110	110	141
KG.DS.160	160	185
KG.DS.200	200	239
KG.DS.250	250	275
KG.DS.315	315	299
KG.DS.400	400	345
KG.DS.500	500	407
KG.DS.630	630	407

■ **Repair Coupling Socket - Socket**

Material: Polypropylene (PP-MD).
Ring Seal: SBR x2 fitted.

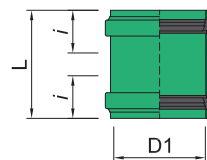

Designed with no centre stopper so the repair coupling can slide entirely over pipe for new fittings to be added and then slid back over the join.

Mark min insertion depth on both spigots to ensure adequate insertion.

Product No	D1	L	i (min)
KG.RC.110	110	141	68
KG.RC.160	160	185	90
KG.RC.200	200	239	110
KG.RC.250	250	275	133
KG.RC.315	315	299	140
KG.RC.400	400	345	185
KG.RC.500	500	394	160
KG.RC.630	630	394	160

■ Plug

Material: Polypropylene (PP-MD).

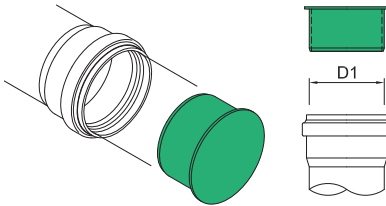

Installing?
 - Leave the ring seal in the KG2000 pipe socket.
 - Fully insert the plug into the socket.
 If the Plug requires to be secured in place, order a Joint Clamp (sold separately).
 Pipe length shown for clarity, not included.

Product No	D1
KG.PG.110	110
KG.PG.160	160
KG.PG.200	200
KG.PG.250	250
KG.PG.315	315
KG.PG.400	400
KG.PG.500	500
KG.PG.630	630

■ Inspection Pipe

Material: Polypropylene (PP-MD).
 Ring Seal: SBR x1 fitted.

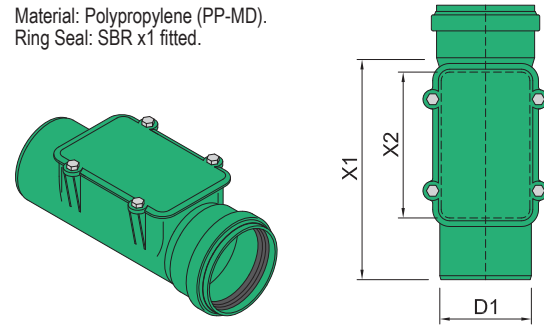

Installation: Door upwards, above ground access

Product No	D1	X1	X2
KG.IP.110	110	308	200
KG.IP.160	160	380	225
KG.IP.200	200	410	

■ Socket Clamp

Material: Metal.

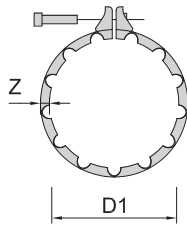

Product No	D1
KG.SCL.110	110
KG.SCL.160	160
KG.SCL.200	200
Diameters 250 to 500:	

Working Pressures (bar)

	In Ground	Clamped Joint*
KG.SCL.110	-0.3 to 3.0	-0.3 to 3.8
KG.SCL.160	-0.3 to 3.0	-0.3 to 3.6
KG.SCL.200	-0.3 to 3.0	-0.3 to 1.9
Diameters 250 to 500:	-0.3 to 3.0	N/A

Socket Clamps are needed where possible pressures or force on a join could dislodge the spigot or cap from the socket.

Vacuum? We recommend joint clamps are used for vacuum applications.

Installing?
 Fit the Socket Clamp over the bump of the socket (as shown dashed above) noting the correct direction...
 - Small lip edge (fit over the socket),
 - Large lip edge (fit over the spigot).

Pipe length shown for clarity, not included.

* Above ground on grade and bracketed suitably to prevent movement.

1 bar = 100 kPa = 14.5 psi

■ P-Trap

Material: Polypropylene (PP-MD).

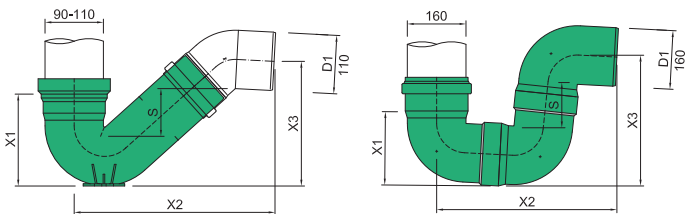

Product No	X1	X2	X3
KG.PT.110	175	380	235
KG.PT.160	200	490	310

Installing?
 - Lubricate the Outlet spigot
 - Add 45° Bend
 - Observe the flow rule (arrow direction).

■ Adaptor: Cast Iron

Material: Polypropylene (PP-MD).

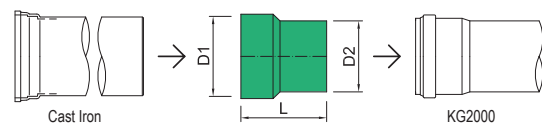

Product No	D1	D2	L
KG.CI.110	122	110	151

Installing?
 - Lubricate the Cast Iron spigot.
 - Fully insert into the PP-MD fitting socket.
 - Bracket/Support suitably to prevent separation.
 - Observe the flow rule (arrow direction).

■ Adaptor: Stoneware

Material: Polypropylene (PP-MD).
 Ring Seal: SBR x1 fitted (D1) in each fitting.

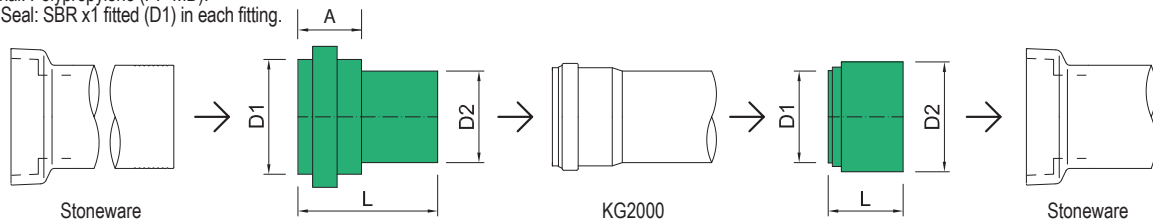

Product No	D1	D2	L	A
KG.SWSP.110	138	110	168	86
KG.SWSP.160	194	160	226	110

Installing?
 - Lubricate the stoneware spigot.
 - Fully insert into the PP-MD fitting socket.
 - Bracket/Support suitably to prevent separation.
 - Observe the flow rule (arrow direction).

Product No	D1	D2	L
KG.SWS.110	110	132	103
KG.SWS.160	160	187	116

Installing?
 - Lubricate the polypropylene spigots.
 - Fully insert into both the PP-MD & stoneware sockets.
 - Bracket/Support suitably to prevent separation.
 - Observe the flow rule (arrow direction).



KG2000 slotted and perforated pipes are designed with either small slots or holes to allow water to exit or enter easily. KG2000 slotted or perforated pipes are designed for the economic removal of excess ground water in areas such as pastures, crop lands, orchards, sports fields, roads, land fill and general construction works. Available in various levels of water entry and exit, through many years of professional engineering and product development, KG2000 pipes retain their SN16 rating.

■ **KG2000-Perforated Pipe**

Perforated (basic pipe KG2000 SN 10).



Product No	Description	Unit/Pallet	Bundle Size
KG.PP10.5000.110	DN/OD 110 x 5000 mm	80	Pallet
KG.PP10.5000.125	DN/OD 125 x 5000 mm	54	Pallet
KG.PP10.5000.160	DN/OD 160 x 5000 mm	35	Pallet
KG.PP10.5000.200	DN/OD 200 x 5000 mm	25	Pallet

Product information for KG2000 perforated in DN/OD 110 - DN/OD 200

Version	Hole lines	Bore diameter (mm)	Drill hole spacing per row (mm)	Number of holes / m	Water entry area (cm ² /m)
Multipurpose pipe	4	Ø 12	240	18	20,3

Multipurpose pipe = the water inlet openings are arranged equally over a range of ≤ 120° at the pipe apex.

■ **KG2000-Slotted Pipe**

Slotted (basic pipe KG2000 SN 10)



Example of partial seepage pipe slotted



Product No	Description	Unit/Pallet
KG.PSM.6000.110.166	EM Multi-purpose pipe slotted DN/OD 110 x 6000 mm (Water entry area 166 cm ² /m)	80
KG.PSM.6000.110.110	EM Multi-purpose pipe slotted DN/OD 110 x 6000 mm (Water entry area 110 cm ² /m)	80
KG.PSM.6000.160.166	EM Multi-purpose pipe slotted DN/OD 160 x 6000 mm (Water entry area 166 cm ² /m)	35
KG.PSM.6000.160.110	EM Multi-purpose pipe slotted DN/OD 160 x 6000 mm (Water entry area 110 cm ² /m)	35
KG.PSP.3000.110	EM Partial seepage pipe slotted DN/OD 110 x 3000 mm (Water entry area 165 cm ² /m)	80
KG.PSP.6000.110	EM Partial seepage pipe slotted DN/OD 110 x 6000 mm (Water entry area 165 cm ² /m)	80
KG.PSP.3000.160	EM Partial seepage pipe slotted DN/OD 160 x 3000 mm (Water entry area 165 cm ² /m)	35
KG.PSP.6000.160	EM Partial seepage pipe slotted DN/OD 160 x 6000 mm (Water entry area 165 cm ² /m)	35
KG.PSF.6000.110	EM Full seepage pipe slotted DN/OD 110 x 6000 mm (Water entry area 220 cm ² /m)	80
KG.PSF.6000.160	EM Full seepage pipe slotted DN/OD 160 x 6000 mm (Water entry area 220 cm ² /m)	35

Product information for KG2000 slotted in DN/OD 110 and DN/OD 160

Version	Slotted rows	Slot width (mm)	Slot length (mm)	Slot spacing per row (mm)	Number of slots / m	Water entry area (cm ² /m)
Multipurpose pipe	4	10	240	100	20	>100 (110)
Multipurpose pipe	4	10	240	100	20	>150 (166)
Partial seepage pipe	4	10	240	100	30	> 150 (165)
Full seepage pipe	4	10	240	100	40	> 200 (220)

Multi-purpose pipe = the water inlet openings are arranged evenly over a range of ≤ 120° at the pipe apex.

Partial seepage pipe = the water inlet openings are arranged evenly over a range of ≤ 220° at the pipe apex.

Full seepage pipe = the water inlet openings are arranged evenly over a range of 360°.



■ **KG2000 Rainwater (blue) EM**

Pipe SN16



Product No	Description	Unit/ Pallet	Bundle Size
KG.PR16.1000.160	KG2000 Rainwater (blue) EM pipe DN/OD 160 x 1000mm SN 16	80	1
KG.PR16.3000.160	KG2000 Rainwater (blue) EM pipe DN/OD 160 x 3000mm SN 16	80	1
KG.PR16.6000.160	KG2000 Rainwater (blue) EM pipe DN/OD 160 x 6000mm SN 16	80	1
KG.PR16.1000.200	KG2000 Rainwater (blue) EM pipe DN/OD 200 x 1000mm SN 16	25	1
KG.PR16.3000.200	KG2000 Rainwater (blue) EM pipe DN/OD 200 x 3000mm SN 16	25	1
KG.PR16.6000.200	KG2000 Rainwater (blue) EM pipe DN/OD 200 x 6000mm SN 16	25	1
KG.PR16.1000.250	KG2000 Rainwater (blue) EM pipe DN/OD 250 x 1000mm SN 16	16	1
KG.PR16.3000.250	KG2000 Rainwater (blue) EM pipe DN/OD 250 x 3000mm SN 16	16	1
KG.PR16.6000.250	KG2000 Rainwater (blue) EM pipe DN/OD 250 x 6000mm SN 16	16	1
KG.PR16.1000.315	KG2000 Rainwater (blue) EM pipe DN/OD 315 x 1000mm SN 16	9	1
KG.PR16.3000.315	KG2000 Rainwater (blue) EM pipe DN/OD 315 x 3000mm SN 16	9	1
KG.PR16.6000.315	KG2000 Rainwater (blue) EM pipe DN/OD 315 x 6000mm SN 16	9	1
KG.PR16.1000.400	KG2000 Rainwater (blue) EM pipe DN/OD 400 x 1000mm SN 16	4	1
KG.PR16.3000.400	KG2000 Rainwater (blue) EM pipe DN/OD 400 x 3000mm SN 16	4	1
KG.PR16.6000.400	KG2000 Rainwater (blue) EM pipe DN/OD 400 x 6000mm SN 16	4	1
KG.PR16.1000.500	KG2000 Rainwater (blue) EM pipe DN/OD 500 x 1000mm SN 16	4	1
KG.PR16.3000.500	KG2000 Rainwater (blue) EM pipe DN/OD 500 x 3000mm SN 16	4	1
KG.PR16.6000.500	KG2000 Rainwater (blue) EM pipe DN/OD 500 x 6000mm SN 16	4	1
KG.PR16.1000.630	KG2000 Rainwater (blue) EM pipe DN/OD 630 x 1000 mm SN 16	2	1
KG.PR16.3000.630	KG2000 Rainwater (blue) EM pipe DN/OD 630 x 3000 mm SN 16	2	1
KG.PR16.6000.630	KG2000 Rainwater (blue) EM pipe DN/OD 630 x 6000 mm SN 16	2	1





Tech Data Sheet: AusPress KG2000 PP Drainage



High Load Ratings



High Temp
90°C Suitable



Diameters
110 - 630mm

What is KG2000?

A high strength polypropylene drainage system, pushed together to install quickly and easily using rubber ring seal socket-spigot joins.

Applications:

Common applications include:

- Stormwater.
- Wastewater & tradewaste.
- Civil & transportation surface water.
- Food & beverage processing.
- Abattoir & meat processing.
- Truck & loading areas.
- Airport & transport aprons.
- Fuel and service station drainage.
- High temperature drainage up to 90°C constant.
- Siphonic drainage.
- Vacuum.
- Other applications on request.

Refer to our Media Chart and Technical Catalogue for specific information and suitability.

Key Features

- Very fast installation process.
- Injection moulded (one piece) SN16 rated fittings standard.
- High impact resistance.
- Smooth internal surface.
- Stocked in Australia in diameters 110 to 250mm.
- Simple process to train users to install using common site tools.
- Low thermal expansion (0.035 10⁻⁶m/mK).
- Long service life and recyclable product.
- One system suits a wide range of applications.
- No need for hot-work permits.
- Efficient and waste free install.
- Adapts to other drainage systems including stainless.

FAQ:

A guide only, refer to full information in the Technical Catalogue:

- What is PP-MD? KG2000 uses a patented mineral modified polypropylene material with a higher strength than standard polypropylene, HDPE or PVC.
- Chemicals? Check both ring seal and pipe material - ask us!
- Load Rating? SN10 and SN16 rated, coverage 0.8 to 6m.
- Suspended? Suitable for vertical and graded installations.
- Exposed? UV stabilised additive, paint and/or protect for long term.

KG2000 Pipe

- Metric OD sizing, **110 to 630mm** – actual outside diameter.
- Mineral modified polypropylene (PP-MD) construction.
- Lengths – different lengths stocked from 1/2m to 6m max, socket-spigot to reduce offcut wastage on site.
- Ring seal pre-fitted to socket end of pipe length.
- Markings – black.

Outer Colour	Inner Colour	Pipe Rating
Green	Green	SN10
Green	White	SN16

Pipe OD	Pipe Wall		Wet Weight (kg/m)
	SN10	SN16	
110	3.4	4.2	10.2
160	4.9	6.2	21.4
200	6.2	7.7	33.6
250	7.7	9.6	52.6
315	9.7	12.1	83.8
400	12.3	15.3	137.5
500	15.3	19.1	217.7
630	19.3	24.1	

Wet weights calculated using full volume filled with water.

KG2000 Fittings

- Injection moulded (one piece), pre-formed fittings, no site fabrication required.
- Metric OD sizing, **110 to 630mm** – actual outside diameter.
- Wide range of fitting types, socket-spigot design.
- Ring seal pre-fitted to socket end of fittings.
- Rated to SN16 (marked with SN8 / SN16 as European standards only require up to SN8 rating).

Ring Seals (Elastomers)

- Triple lip design, pre-fitted to socket ends as standard.
- SBR rubber type standard.
- NBR type option available for contaminated waters, such as oil.

Seal Type*	Colour	Temp Range*
SBR	Black	-20 to 90°C
hNBR	Grey	-20 to 90°C

*Maximum constant - refer to our Media Chart & contact us for suitability before installation.

Installation:

Simply cut the pipe to length square, bevel the cut end, lubricate the seal and push/twist together to join.

Suitable to pass through concrete providing movement is allowed and socket is not embedded.

Fire collars suitable, must not be positioned over the socket.

Pressure Ratings:

The maximum working pressure for inground installation of all KG2000 diameters is 300kPa (3.0 bar).

Suspended or vertical exposed insulation, higher values are possible with suitable bracketing and joint clamps fitted – please contact us for more information.

System Approvals & Compliance:

- WaterMark AS 5065
- AS 3500.3

Technical Assistance

- Suitability checks for projects & applications on request.
- Tech Notes and Media Chart product reference material.
- AusPress staff available across Australia & New Zealand.

Need More Information?

Please contact us for product support, technical advice or your project specific requirements:

- Phone: 1300 287 773
- Email: sales@auspress.com.au

Visit auspress.com.au for the latest product information, tech notes & catalogues.

Technical Guide

AusPress Polypropylene Drainage Products

The following information is only a guide. All work must comply with AS/NZ 3500 and any other relevant standards applicable to the installation.

For specific installation assistance, or if you're in doubt, please contact us before proceeding.

As with all work using tools, the following points are to be adhered to and understood, along with the general safety practices such as wearing suitable clothing and equipment, being alert and focused, keeping the work area clear of obstacles and observing WHS (OH&S) requirements.

Installing KG2000 Drainage

Polypropylene Drainage Pipe & Fittings

The socket-spigot polypropylene (PP-MD) drainage system comprises directional pipe and fittings (installed with flow into the socket, out the spigot) with the socket pre-fitted with a rubber ring to seal each join.

Refer to the installation guide at the front of the catalogue section for more information.

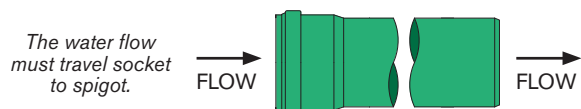

1. Ring Seals

Ring seals are fitted to each socket end with an SBR type supplied pre-fitted as standard.

Check the ring seal is free of debris and the correct type of seal is fitted for the application and temperatures to be used. **Not sure? Ask!**

Ensure the 3-lip ring seal is fitted correctly with taper facing inward (see image).

Replace the seal if damaged, unsure or incorrect. Remove the seal to see the type labelled on the inside flat surface of the ring seal.

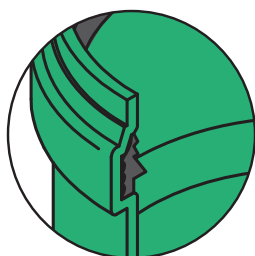

2. Joining

Material	Colour	Application [†]	Temp Range
SBR (Styrene-butadiene)	Black	General use	-20° to +90°C
NBR (Nitrile butadiene)	Black	Oil & fuels	-20° to +90°C

[†] Confirm suitability with AusPress prior to installation.

Apply lubricant to ring seal & outside of spigots.

Preferred lubricant is silicon based (such as Super Glidex) but an approved soap based lubricant can also be used. Grease is not to be used as this may damage ring seals.

Push the spigot into the socket fully with a slight turning movement.

Mark the spigot end to identify the full insertion depth with a waterproof permanent texta.

Joint is then pulled back 10-12mm to allow for expansion and contraction within the socket.

3. In-Ground Installation

The KG2000 system is suitable for in-ground installation following AS/NZS 2566.1, especially;

Bedding and surrounding fill is to support the full length of the pipework and,

A minimum bed thickness of 100mm fine soil or sand below the pipework (150mm if trench rocky or solid for example concrete) and,

In heavy duty areas (SLW 60) coverage shall be between 0.8 and 6m in depth above the pipework to the underside of ground level or structure (such as road base).

4. Good Practice

Preference installing 45° branches.

All main horizontal 90 degree direction changes should be made using 2 x 45° bends with a minimum 150mm length between.

Venting procedures must comply with AS/NZ 3500.

5. Welding

If welding is to be carried out, written approval must be obtained from AusPress first.

Bracketing, Above Ground Graded Suspended & Vertical

Bracketing is to comply with AS/NZ 3500.

Spacing distances apply to continuous straight lengths.

Installation is to be designed to suitably support the drainage system at full volume and accommodate any external loads or movement (thermal or otherwise).

At joins in the suspended drainage, additional fixing points must be placed that either the branch, or the through pipe, is held directly under the sleeve (not on the socket part).

Changes in direction shall be supported with suitable bracketing to prevent movement & the join separating.

Consideration for forces against change in directions (including vertical drops) must be provided to suit and securing any joins as part of the installation (such as thrust blocks).

Diameters:		110 - 315mm	400 - 630mm
Support Spacing (max)	Graded	1.0m	Not Suitable
	Vertical	2.0m	2.0m

As per AS 3500, Table 9.1. AS 3500 is limited to DN300 (315mm) in diameter. Engineer assessment and confirmation is recommended.



Working with Concrete

Polypropylene is suitable to be embedded in concrete with the following precautions;

Protect the joint to prevent concrete entering the socket (tape the joint gap with tape optional).

Ensure the pipes do not uplift with supports consistently along the drainage to prevent sagging points.

Thermal movement is allowed for the installation.

Fire Collars

When passing through fire-rated building elements, the installation of a fire collar is not to be positioned over the socket part of the pipe or fittings. Collars are to be installed as per manufacturers instructions. Consult standards for local requirements.

Chemical Suitability

Although highly chemical resistant, some chemicals are not suitable for polypropylene, diluted or otherwise. Please confirm suitability with the chemical manufacturer before use or contact AusPress for an assessment.

Complete a Project Info Sheet with the relevant MSDS and details from our website.

Heat Tracing

KG2000 is suitable for heat tracing - please contact us for more information. Note to specify the NBR seal for grease and oil based contaminants up to 40°C.

Expansion & Contraction

Pipes in any direction (including horizontal suspended and horizontal in-ground) must be supported to prevent the force arising through heat expansion can neither bend the pipes nor pull the spigot ends from the sockets.

The formula $E=L \cdot T \cdot \alpha$ calculates the expected expansion of polypropylene (PP) with change in temperature where $\alpha=0.035 \times 10^{-6}m/mK$. The thermal coefficient of PP is much lower than other plastics including HDPE and PVC.

Ensure the spigot ends are retracted the 10-12mm from the socket after full insertion.

Commissioning & Maintenance

In most environments, little or no maintenance is necessary.

Ensure wash down waters or waste debris do not contain chemicals that are not suitable for polypropylene.

In especially demanding environments, such as food processing, chemical industries and agriculture, it may be necessary to clean to avoid coating. Cleaning can be carried out with high-pressure cleaning or high pressure flushing equipment using potable water. Avoid scratching or roughing the pipe surface with equipment.

In cases of difficulty, users should consult us for technical advice.

Disinfecting the System

This is carried out to meet more stringent hygiene requirements and in the event of severe microbial contamination. Contact us for more information.

To protect the environment and simplify handling, the Australian Drinking Water Guidelines (ADWG) recommend the use of hydrogen peroxide, however chlorine can also be used to disinfect.

Before commissioning the system carefully follow the instructions for use, particularly in relation to the contact time, maximum solution concentration and subsequent flushing requirements.

Note: During disinfection do not exceed the maximum chlorine concentration and contact times as tabled below:
The Australian water regulations allow dosing with up to 1.2mg/l of free chlorine in the disinfectant solution, provided a limit of 0.3mg/l of free (active) chlorine is not exceeded in the drinking water.
Quantities can be increased to 6mg/l and 0.6mg/l respectively in exceptional circumstances for example, high or increased micro bacterial contamination.

Flushing the System

It is sufficient to simply flush the system with potable (drinking) water.

When using any solution, ensure the system is flushed correctly and the manufactures instructions are followed in an accurate and safe manner at all times.

Chemicals are to be confirmed suitable with polypropylene and within temperature limits of the system prior to flushing the system.

Commissioning

Systems must be commissioned in accordance with the applicable standards and regulations.

The installation contractor must familiarise the user(s) with the system. This is to be documented with a hand-over and acceptance record.

The user must also be provided with the manufacturer's maintenance and operating instructions for all installed valves and equipment.

Storage in Direct Sunlight

KG2000 pipes and fittings do not have UV protection against direct sunlight. Care should be taken when considering long term effects to avoid surface fade / chalking (UV).

Information below in accordance with DIN CEN/TS 14758-3 on the outdoor storage of KG2000. If pipes and fittings are exposed to direct sunlight for long periods of time deformations may occur which may have an influence on the subsequent connections.

In order to avoid this, the following precautionary steps should be taken:

- Height of pipe stacks must be limited
- Pipes and fittings should be protected from constant and direct sunlight and arranged in such a way for unobstructed air supply.

Fading of pipe components due to outdoor storage does not effect mechanical properties of KG2000 pipes and fittings.