

# The Strength of Press-Fit

## It's All In The Join

The socket on each press fitting is fitted with a rubber ring seal, engineered to provide both a strong and sealed joint after being pressed with a press tool.

By using a calibrated press tool, each join is permanent and uniform as the join is deformed in two ways;

- The engineered shaping of the fitting against the tube to provide strength to the join as the primary seal plus,
- The deformation of the rubber ring seal to form the secondary seal in the encapsulated pocket between the fitting and tube.

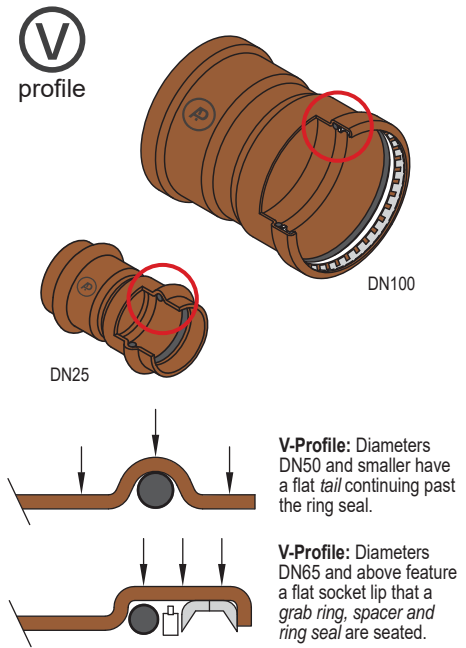
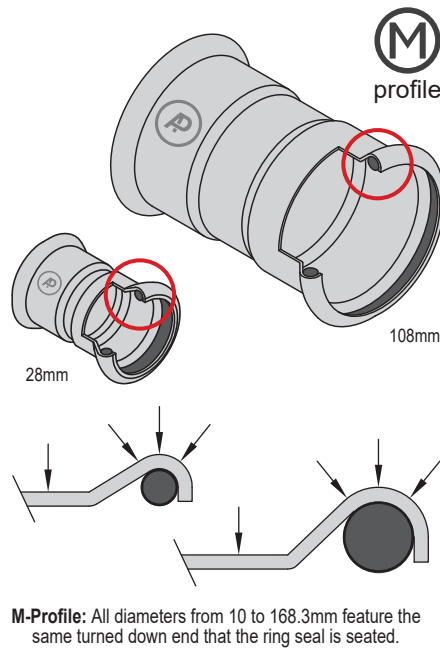

The press jaw (or collar) determines the shape and it is important to ensure the jaw (or collar) used with the press tool matches not only the diameter but also the fitting profile to ensure a successful pressed joint.

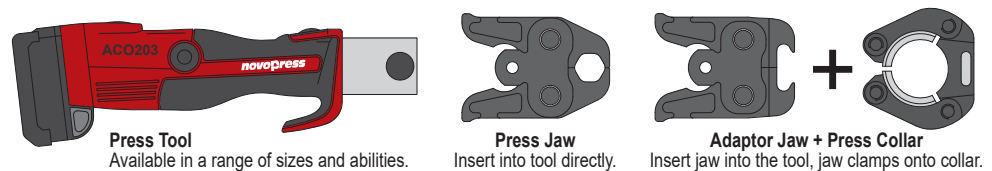

**Above:** Press Tools are fitted with an interchangeable jaw or, adaptor jaw and collar combination depending on the fitting material, system diameter and fitting press profile to be pressed. All must match for the press to be successful.

Since the original M-Profile was invented by Larsson, other profiles have been developed based on his design. Although appearing to be similar, each profile performs with different strength, deformation and ability characteristics.

### DID YOU KNOW?

Originally designed in 1962 by Swedish engineer Gunther Larsson, the first press fittings were manufactured by German company Mannesmann from 1969.

Two different cross section shapes are pressed depending on the tube diameter - the hexagonal and the lemon shape.

**Section A:**  
This forms the mechanical strength of the pressed join.

**Section B:**  
The deformation of the rubber ring seal ensures a permanently tight join.

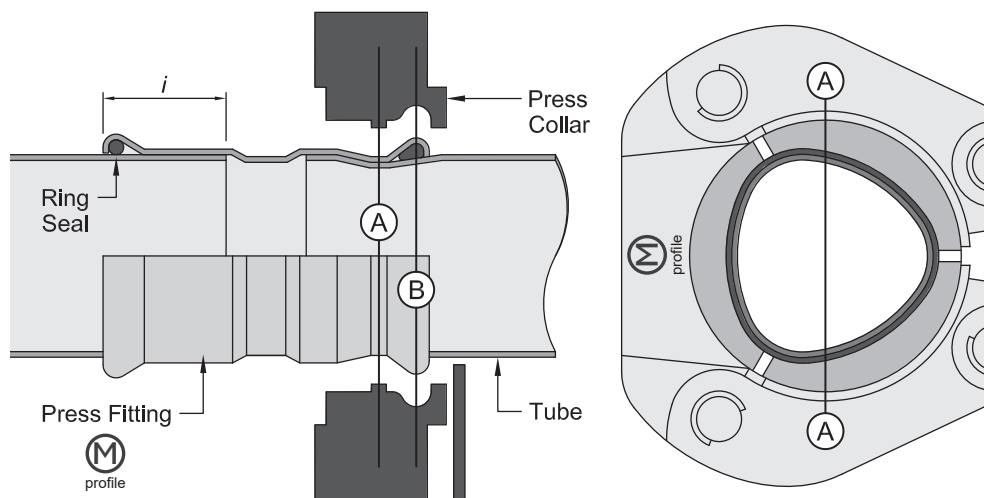
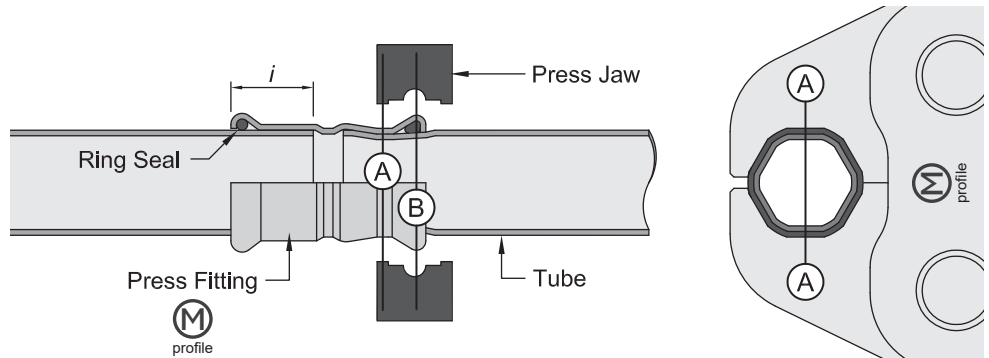



# Using a Press Tool

## The Tool Does All The Work

Press Tools are designed specifically for the installation of press fittings and come in a range of shapes and sizes. They often have an on-board computer that controls the press pressure, duration and other quality control parameters that is recorded on the press tool.

Press fittings can only be pressed with a press tool that is fitted with the correct jaw or collar that matches the profile type and diameter of the fitting. After a successful press, a permanent joint between the fitting and the tube is made.

**Different press tools have different abilities and determine the working pressure of the completed system so use the 'Select a Press Tool' charts at the start of each section to check for suitability.**

Every press tool is slightly different so check with the tool manufacturer for their specifications and operating instructions.

**Read in conjunction with the Installing AusPress guide at the start of each catalogue section.**

- 1 Check the press jaw (A) or collar (B+C) matches the profile and diameter of the fitting and is suitable for the press tool.
- 2 Retract the retaining pin (RP) of the tool and insert the jaw into the press tool. Once seated, close the retaining pin.
- 3 Open the press jaw and align the inner groove of the jaw with the raised profile of the fitting.
- 4 Check the fitting is fully engaged by the insertion depth mark and if so, press and hold the start button (GO) to begin the press.
- 5 Once complete the tool will 'click' and retract the internal roller pins. Open the press jaw and move away from the fitting.
- 6 An occasional spray with Inox lubricant on the jaw moving parts and press zone will ensure ongoing smooth operation.

## Tool, Jaw & Collar Calibration

Tool calibration show when next due for calibration.



Example shows due 07/2016

## Half or Cancelled Press?

If the press tool operation is stopped before completing a full press cycle, the press tool must reset before removing the jaws. **Press fittings cannot be re-pressed.**

## Tool Training & Safety

For OH&S and product warranty reasons, before using a press tool you must of completed the relevant AusPress Tool Training.

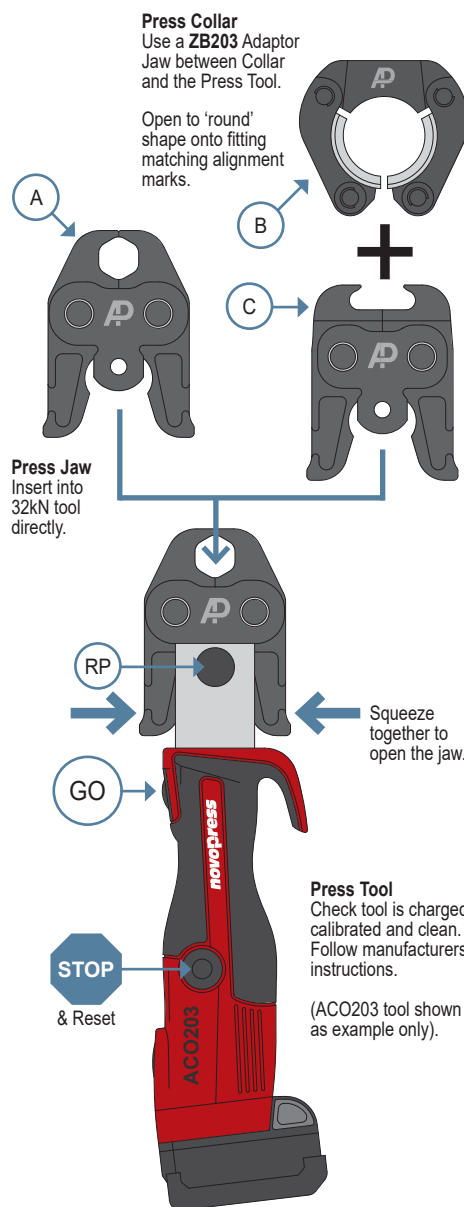

## Use the Right Tool...

The Press Tool used determines the maximum working pressure of the installation.

Use the 'Select a Press Tool' chart to check suitability.



## Safety & Tool Training

We offer onsite tool training and maintain records of attendees for OH&S and Quality Assurance.

## Tool Servicing

We're authorised press tool repair & service centre for our Novopress & Vetec tools.

## Tool Maintenance

**Every 10x Presses:** Lightly lubricate inside press zone groove of jaws & collars with an Inox spray.

## Weekly:

Lubricate and inspect press jaws and collars for wear or damage.

## Regular Servicing:

Refer to manufacturer's tool manual for service interval & warranty details.

## Tool Not Working?

- Press the Reset Button?
- LED status?
- Contact Us...

## Green LED

- Off = Tool is on standby or press is in progress.
- Steady = Tool is ready.
- Flash = Check retaining pin or Battery Charge.

## Red LED

- Steady = Fault / Service.
- Flash (x3) = Extreme temperatures or tool fault.

## Red & Green LEDs

- Flash = Service.

## Generators

Please contact us before using generators with the 240V Press Tools.

## Batteries

Press tools generally don't commence a press unless there is enough battery charge to complete a press.

# Jaw & Collar Clearances

Measurements are dependant on the actual fitting dimensions and the Press Tool used to join. Confirm clearances before proceeding with your installation.

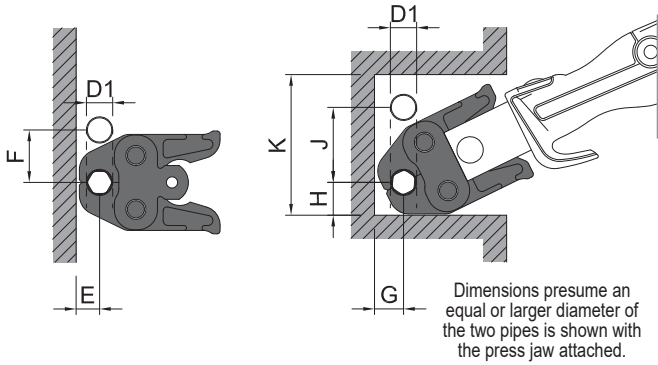

Measurements may differ depending on the press tool, jaw or collar model used. ACO203 tooling options used as example only.

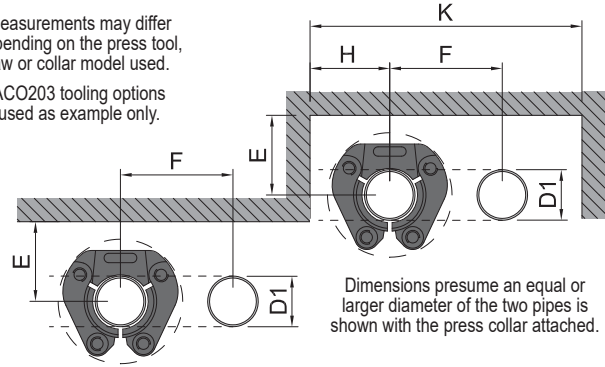

Dimensions for AusPress Metric 316 Stainless, AusPress CuNiFe & AusPress 2205 Fittings

D1	T	E	F	G	H	J	K
10	Jaw	20	56	25	31	75	135
15	Jaw	20	56	25	31	75	135
22	Jaw	23	65	31	38	80	155
28	Jaw	25	75	31	39	83	160
35	Jaw	30	75	36	45	90	180
42	Collar	75	115	-	75	-	265
54	Collar	85	120	-	85	-	290
76.1	Collar	110	140	-	110	-	360
88.9	Collar	120	150	-	120	-	390
108	Collar	140	170	-	140	-	450
168.3	Collar	200	335	-	200	-	850



Dimensions for AusPress Copper Fittings

DN	T	E	F	G	H	J	K
15	Jaw	20	56	25	31	75	135
18	Jaw	23	65	31	38	80	155
20	Jaw	23	65	31	38	80	155
25	Jaw	25	75	31	39	83	160
32	Jaw	30	75	36	45	90	180
40	Jaw	50	90	68	54	92	265
40	Collar	67	110	-	82	-	274
50	Jaw	64	121	60	90	125	295
50	Collar	71	121	-	90	-	300
65	Collar	110	140	-	110	-	360
80	Collar	120	150	-	120	-	390
100	Collar	140	170	-	140	-	450

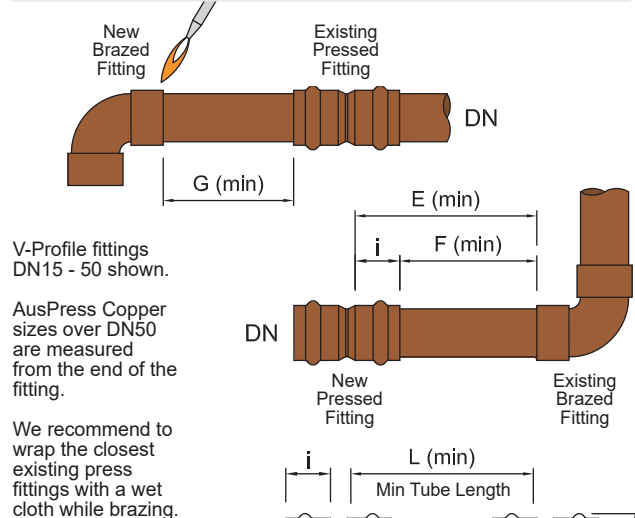
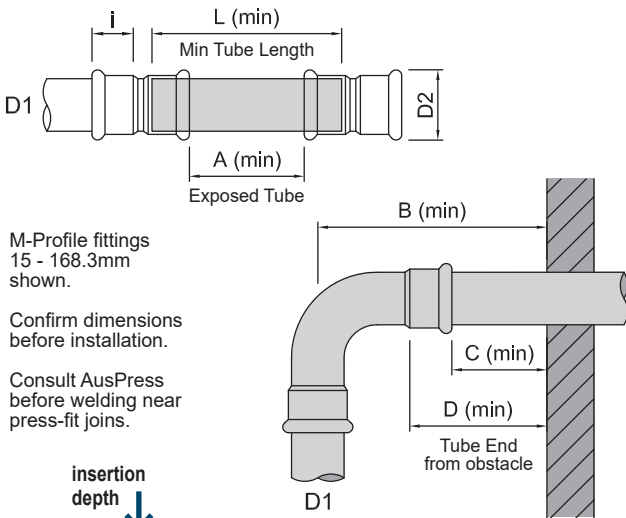

D1	i	L	A	D2	B	C	D
10	10	50	30	16	62	35	45
15	20	50	10	23	85	35	55
22	21	52	10	32	95	35	56
28	23	56	10	38	107	35	58
35	26	72	20	45	121	35	61
42	30	80	20	54	147	35	65
54	35	90	20	66	174	35	70
76.1	53	126	20	95	223	75	128
88.9	58	136	20	110	249	75	135
108	69	158	20	133	292	75	150
168.3	121	302	60	195	456	70	191

DN	i	L	A	D2	E	F	G
15	19	51	13	20	32	13	350
18	21	55	13	24	34	13	380
20	22	57	13	27	35	13	500
25	23	61	15	34	38	15	650
32	26	67	15	41	41	15	800
40	32	84	20	19	52	20	1,000
50	40	105	25	61	65	25	1,300
65	42	109	25	79	67	25	1,600
80	48	126	30	90	78	30	2,000
100	60	150	30	116	90	30	2,500



# Material Performance

## Material Composition



		AISI 316L	AISI 304	AISI 316L	90/10	C12200	AISI S31803
<b>Grade No:</b>		<b>1.4404</b>	<b>1.4301</b>	<b>1.4404</b>	<b>2.1972</b>	<b>C12200</b>	<b>1.4462</b>
Chromium (Cr)	%	16.5 - 18.5	18 - 19.5	16.5 - 18.5	-	-	21.0 - 23.0
Carbon (C)	% max	0.03	0.03	0.03	0.05	-	0.03
Copper (Cu)	% min	-	-	-	85.6	99.9	-
Iron (Fe)	%	bal	bal	bal	1.5 - 1.8	-	bal
Lead (Pb)	% max	-	-	-	0.01	-	-
Manganese (Mn)	% max	2	2	2	1	-	2
Molybdenum (Mo)	%	2 - 2.5	-	2 - 2.5	-	-	2.5 - 3.5
Nickel (Ni)	%	10 - 13	8 - 10.5	10 - 13	10 - 11	-	4.5 - 6.5
Nitrogen (N)	%	-	-	-	-	-	0.08 - 0.20
Phosphorus (P)	% max	0.045	0.045	0.045	0.02	0.04	0.03
Silicon (Si)	% max	1	1	1	-	-	1
Sulphur (S)	% max	0.015	0.03	0.015	0.005	-	0.02
Zinc (Zn)	% max	-	-	-	0.05	-	-
Zirconium (Zr)	% max	-	-	-	0.01	-	-
PREN	ave	24.9	18.8	24.9	-	-	34.2

## Temperature Correction Factor

The graph below shows the correction factor (Kc) based on the water temperature.

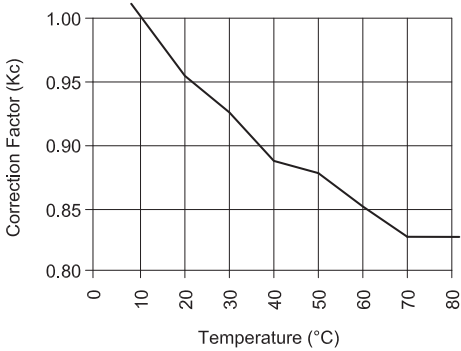

## Batch Numbers (Tube & Fittings)

Our fittings and tubes are marked with a batch (or heat) number identifying the material as part of our 3.1 certifications for our 316, IPS & 2205 ranges.

## Pressure Loss & Flow Rates

The graph adjacent shows the relationship between pressure loss, flow velocity for each diameter.

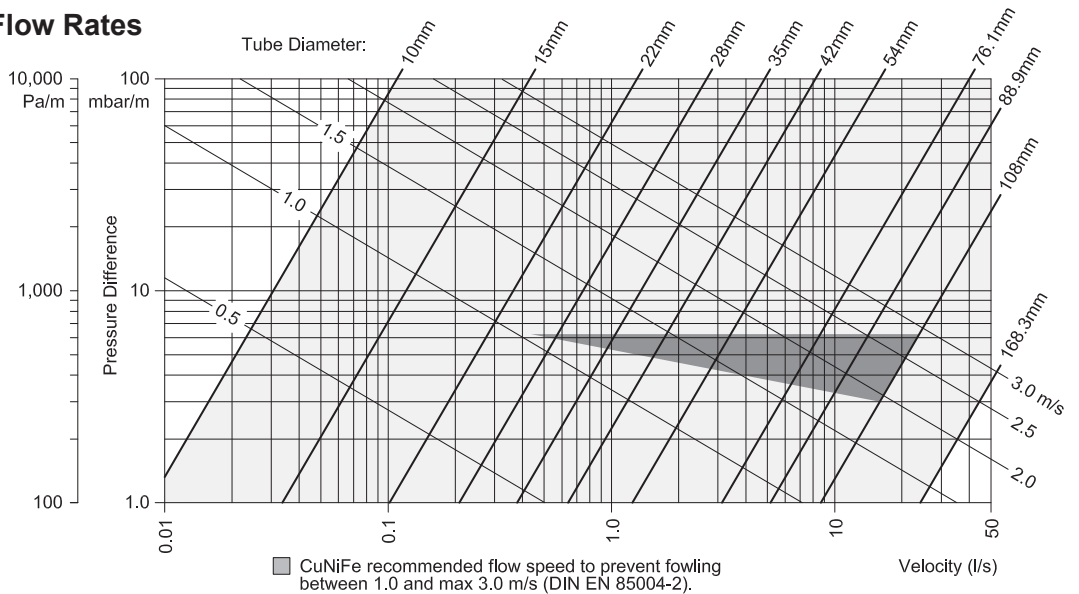

### Test Details

- Material: Stainless Steel 316L
- Media: Potable Water
- Test Temperature: 10°C
- Surface Roughness Coefficient: 0.0015mm (average)

# Expansion & Contraction

## Calculate the Expected Thermal Movement

The table below shows the relative longitudinal expansion of 316L stainless steel tubes 'E', based on the **difference (change) in temperature** between the external environment and the internal media using the formula below...

Tube Length	Expansion Length, Longitudinal (E)										
	ΔT:	10	20	30	40	50	60	70	80	90	100°C
1m		0.17	0.33	0.5	0.66	0.83	0.99	1.16	1.32	1.49	1.65mm
6m		1.02	1.98	3.0	3.96	4.98	5.94	6.96	7.92	8.94	9.90mm

Note: Positive values are expansion, negative values are compression.

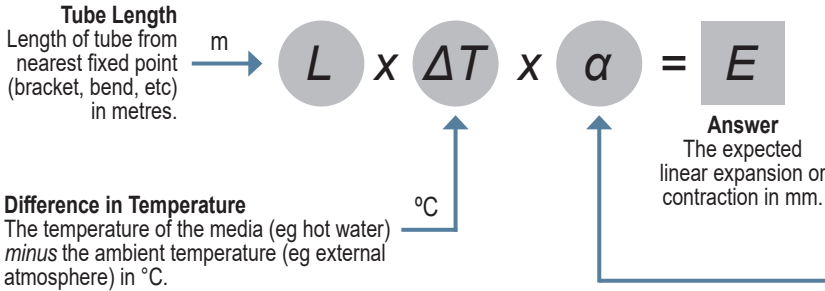

### Thermal Coefficient (10<sup>-6</sup>m/mK)

Different materials have different thermal properties, identified by the expansion coefficients below (between +20 to +100°C).

The larger the number, the greater the material will expand per metre.

Material	α
Carbon Steel	0.0117
<b>Stainless Steel (2205)</b>	<b>0.0137</b>
<b>Stainless Steel (316L)</b>	<b>0.0165</b>
Stainless Steel (304L)	0.0166
<b>Copper (Cu)</b>	<b>0.0168</b>
<b>Copper Nickel (CuNiFe)</b>	<b>0.017</b>
PEX	0.018
Aluminium	0.0231
PP-RP	0.035
PVC-U	0.0504
ABS	0.063
HDPE	0.12
PE	0.15

**Note:** Confirm product specific coefficients with manufacturer.

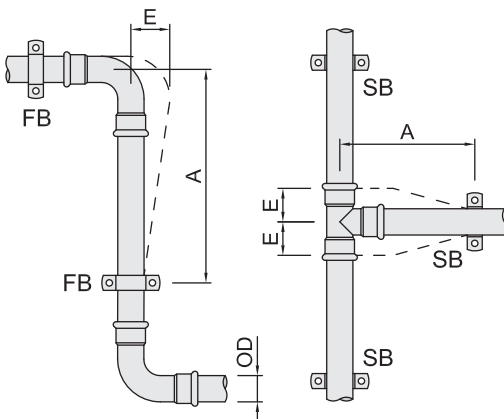

**Above:** 'Z' & 'T' Shape Arrangements. Can also be achieved with cold bending the tube (up to 35mm). Use the chart below to calculate measurement 'A' based on the diameter.

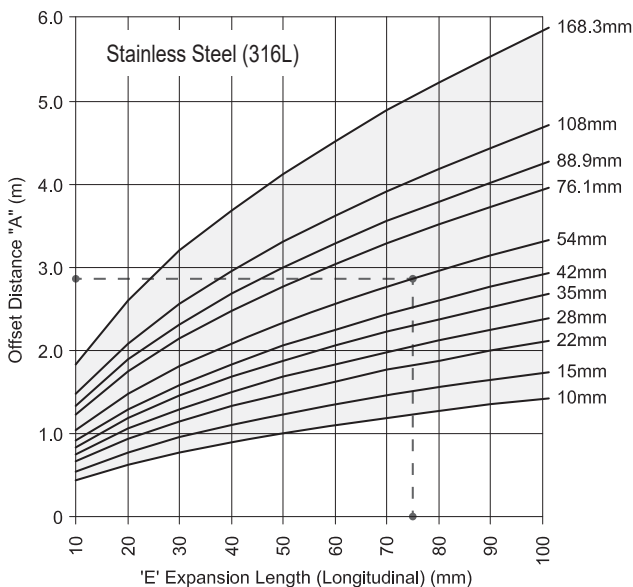

**Above:** 'Z' & 'T' Shaped Arrangements - based on  $A = 0.045 \times \sqrt{(\text{Tube OD} \times E)}$ . In the equation, for CuNiFe use the constant 0.054; for Copper use 0.061.

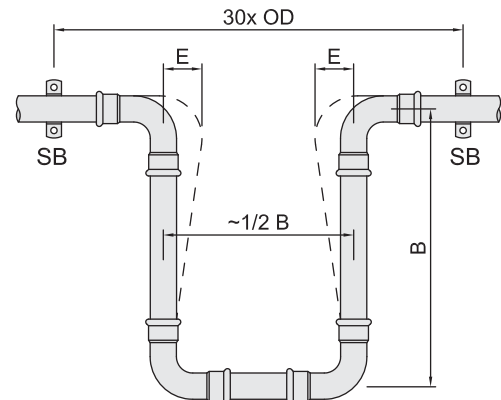

**Above:** 'U' Shape Arrangement. Can also be achieved with cold bending the tube (up to 35mm). Use the chart below to calculate measurement 'B' based on the diameter.

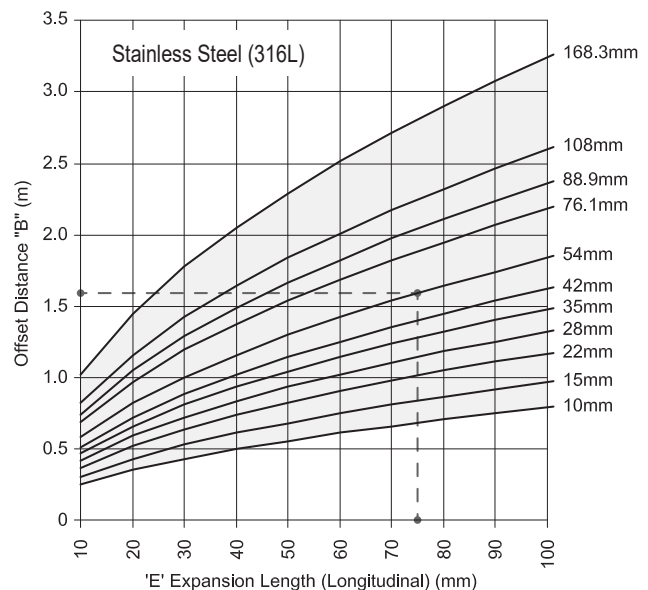

**Above:** 'U' Shaped Arrangements - based on  $B = 0.025 \times \sqrt{(\text{Tube OD} \times E)}$ . In the equation, for CuNiFe use the constant 0.031; for Copper use 0.032.

# Design for Press-Fit

This information is suitable for 'normal' applications within the abilities of press-fit including potable water and compressed air however some applications require additional consideration; these include (but not limited to) steam, pressurised oil lines and chemical lines. In these instances, contact us before installation for technical assessment.

The following information is a general guide only. For project & application specific assessment, contact us directly.



## Tech Notes Available

Contact us for Technical Notes that cover topics in much greater detail.

## 1: Ring Seal (Elastomer) Suitability

The rubber ring seal is an important part of the press fitting join and must be assessed as suitable for the application and media to be used. AusPress fittings are supplied with a pre-fitted EPDM (black) ring seal standard, unless otherwise noted at the time of ordering. We don't recommend the swapping of ring seals from one type to another after the time of ordering.

**Refer to our *AusPress Suitability Guide* for specific ring seal suitability and limits and/or contact us for confirmation before installation by completing a Project Information form available from our website.**

## 2: System Pressures

Maximum working pressure depends on a combination of the press tool used to install, the fitting profile, fitting diameter, the system material, operating temperature and application (use) as approved by AusPress. Some applications are limited to a lesser pressure despite the system able to achieve higher; in these cases, the lesser pressure is used.

- Working Pressure – 'normal' operating pressure, designed for and in accordance to relevant standards.
- Test Pressure – 1.5x the working pressure, during site test conditions only (see Pressure Testing section).



**Refer to the 'Select a Press Tool' page at the beginning of each AusPress catalogue section to find the right tool for your project.**

For suitability of other press tools, applications and limits for AusPress products, please contact us for advice.

## 3: Insulation & Lagging

Insulating AusPress is suitable however consideration must be given to the piping material and the insulation type to be installed. *Tech Note available.*

For example, insulation materials used with stainless 316 must be specified 'low chloride' (less than 0.05% soluble chloride ion content by weight). This issue is critical to the performance of stainless installations at any temperature.

## 4: Threaded Fittings & Sealants

Support the threaded press fitting using the fixed nut to tighten and prevent torsional forces being applied to the pressed join.

For threads, both thread tapes and liquid/paste sealants must be chloride free and suitable with the material and application.

Contact us for more information.

## 5: Bracketing

Install bracketing & centres (spans) to AS/NZS 3500 & AS/NZS 4041 as required appropriate to the application.

Bracketing is to be the same material as the pipework or separated with an inert lining such as rubber.

Brackets are not to be positioned directly on a fitting.

Refer to the Expansion & Contraction section for bracket type and positioning.

## 6: Bending Tubes

Tube up to 35mm diameter can be cold bent using a commercial tube bender to a radius no less than 3.5x the tube diameter. Do not heat stainless or CuNiFe to bend.

## 7: Material Suitability

AusPress is suitable for a range of applications; please complete a Project Info Form and contact us for product suitability based on your project requirements.

### Press-Fit for Potable Water

AusPress systems are resistant to potable water meeting the requirements of the Australian Drinking Water Guidelines (ADWG) 2011.

- Stainless & copper are resistant due to the protective layer these materials create naturally. The content of water-soluble chloride ions at ambient temperature (including in potable water) should not exceed 250mg/l (250ppm).
- Copper Nickel (CuNiFe) is not suitable for potable water applications but can be tested with potable water.

Problems can occur with high chloride content found in some chlorous disinfectants or naturally occurring sources such as bore water. Confirm suitability with AusPress before use.



**Stagnant water, low flow periods and dead legs require caution and are not recommended.**

Water analysis testing by a NATA certified laboratory is required to confirm the composition of waters.

### Press-Fit for Purified Waters

Purified waters such as softened, de-carbonised, fully desalinated, de-ionised, de-mineralised, distilled and pure condensates are suitable. Ultrapure water with a conductivity of < 0.1 µS/cm is also suitable. No additional measures to protect against corrosion are necessary.

Other types are to be confirmed before installation on request.

Water sample and parameters may be required. Note Copper and CuNiFe are not suitable for purified water types.

### Press-Fit for Chemicals, Disinfectants and Additives

Please complete a Project Info Sheet with the relevant MSDS and contact us to check the suitability.

Continued...

### Press-Fit for Compressed Air

Dry or wet (lubricated) systems are suitable with AusPress; use the FKM ring seal for wet systems or when oil is possible.

### Press-Fit for Wet Steam

Only the Red FKM ring seal is suitable for wet steam. Water quality and additives must be confirmed as suitable. For AusPress stainless, max limits of 75 psi (550 kpa) & 160°C installed with pressure relief valve, temp gauge & suitable press tool. Contact us for advice and the *Tech Note*.

### Press-Fit for Oil, Fuels, Grease & Viscous Liquids

Systems must be installed with a thermal expansion safety valve, the pump isolated and system depressurised during non-operational periods. Confirm the ring seal suitability before installation. *Tech Note available*.

### Press-Fit for Sewer, Stormwater or Gravity Waters

Press-Fit is not suitable, designed or approved for these applications. Contact us for information about our range of stainless drainage pipes and floor drains.

### Press-Fit in Cold Climates

Allowance must be allowed for expansion of water within the pipework that may freeze. Various methods such as trace heating are used, please contact us for specific advice.

## 8: Protecting External Surfaces

### Material Resistance

Despite the robust protective layer to the material formed naturally, the external environment and conditions must be considered; contaminants settling or in contact for a period of time may effect the outside surface of the tube & fittings.

For example;

- 316 stainless is susceptible to chlorides; coastal areas where the tube is exposed, unwashed or buried;
- Building materials in contact such as concrete, galvanised brackets or grinding sparks;
- Chemicals (including cleaning), alkaline or acidic environments where AusPress is to be installed;
- Underground installation of press-fit is not recommended where protection from damage, interference from plant roots or soil/groundwater conditions is not provided. Refer our Tech Note for more information.

### Protection of External Surfaces

In areas at risk of unsuitable external conditions, installation of AusPress without protection is not recommended - contact AusPress for advice before installation.

To prevent against direct contact issues, installing press-fit using off-set brackets, material separation (such as inert rubber spacers) and other 'material' solutions is suitable.

Covering the external surface can protect and insulate the surface from contaminants. Care to prepare the press-fit surface before applying the covering is critical to prevent locking any contaminants between the tube and protection.

Protection against external contaminants must be waterproof and non-porous and resistant to heat and ageing and continuous (no gaps or damage). The use of encased or sealed blanket insulation, allowing to drain trapped condensation and barrier wrapping are all recommended. Materials that retain moisture including felts are not recommended.

### Effects of Bi-Metal (Mixed) Installations

Caused by the direct connection of different materials or the water passing from one material to another (the flow rule), bimetallic reactions can effect some metals.

AusPress stainless is not effected by the flow rule and with potable water can be used with other nonferrous metals although this is not a preferred method of installation.

Colouring caused by deposits of other metals does not necessarily indicate corrosion.

Materials that do bimetallicly react are separated by an inert section to reduce the reaction.

For example, if stainless is directly connected to galvanised steel pipe, bimetallic reaction will occur to the galvanised steel. This can be prevented by:

- Installing an inert separation piece between the two or;
- Fitting a ball valve made of non-ferrous material.

## 9: Flushing the System

It is best practice to avoid the introduction of foreign matter or contaminants during installation including dirt and swarf. Flushing the pipework is recommended to reduce the negative effects contaminants may cause and AS/NZS 3500 has further directions for flushing water supply systems.

- **Flushing Water Systems:** Potable water is recommended.
- **Flushing Air, Oil & Gas Systems:** Use oil-free air or an inert gas such as carbon dioxide or nitrogen. Oxygen or other flammable gasses are not to be used.

## 10: Pressure Testing

Conduct the pressure test in accordance with AS/NZS 3500 (and AS/NZS 2419.1 for Fire Hydrant applications).



**If the system is to be emptied again after a water pressure test, or not remain completely full, it is advisable to conduct the pressure test with air in order to avoid an increased risk of pitting and corrosion.**

- **Testing with Water:** Potable water is recommended.
- **Testing with Air:** Use oil-free air or an inert gas such as carbon dioxide or nitrogen. Oxygen or other flammable gasses are not to be used.

### Water Supply Systems:

Flush the system then fill with potable water so that it is free from air pockets before commencing the test. If connecting to an existing water supply, flush any connecting pipework before connection.

### Hot and Warm Water Systems:

In addition to the notes above for Water Supply Systems, conduct the preliminary and main tests with cold water first. As soon as possible after a successful cold water test, slowly heat up the system to the full designed hot water temperature and re-inspect for any issues.

Note the system will expand when heated and bracketing should not be fully tightened nor insulation fitted before normal operating temperature has been reached.

Continued...



### LPG and Natural Gas Systems:

Conduct the pressure test of the system in accordance with AS/NZS 5601. Water is not a suitable medium for testing, use the air testing method.

#### Pressure Test Process:

We recommend using the Test Protocol Form to record the test results as a record that can be downloaded from our website. Use the more stringent requirements of those listed below and the relevant AS/NZS standard to your installation.

	Test Pressure (the greater of):		Minimum Test Time Required:
AS/NZS 3500	1,500 kPa or...	1.5 times the maximum operating working pressure for the system.	45 minutes
AS/NZS 5601	7.0 kPa (pipework only) or...		2 minutes temp stabilisation time + 5 minutes for test
AS/NZS 2419.1	1,700 kPa or...		4 hours
Refer to the relevant standard for specific requirements of testing.			

- For hot water systems, the duration may be longer allowing for the water to heat after the first cold water test.
- For flange pressures, consult the relevant standard (ie AS/NZS 2129 for Table & ASME B16.5 for ANSI).

System considered 'passed' if:

No pressure drop over the test duration (as per relevant AS/NZS for the installation) and a visual inspection confirmation of no leaks or deformation.

### 11: Disinfecting the System

Prior to commissioning the system or in the event of microbial contamination, the Australian Drinking Water Guidelines (ADWG) recommend the use of hydrogen peroxide to disinfect pipework. Chlorine is also listed as suitable in this context.

**Please contact us so we can offer project specific advice before you proceed.**

Familiarise the manufacturer's safety precautions of using the chemical and instructions for use, particularly in relation to the contact time, maximum solution concentration and subsequent flushing requirements.

- The Australian water regulations allow dosing with up to 1.2ppm of free chlorine in the disinfectant solution, provided a limit of 0.3ppm of free (active) chlorine is not exceeded in the drinking water.
- Quantities can be increased to 6ppm and 0.6ppm respectively in exceptional circumstances for example, high or increased micro-bacterial contamination.

To prevent damage to AusPress products during disinfection, do not exceed the maximum chlorine concentration and contact times as tabled:

	Option 1	Option 2
Maximum concentration of free chlorine in water:	100ppm	50ppm
Maximum contact time:	16 hours	24 hours
Thorough flushing with potable (drinking) water:	Residue free chlorine in potable (drinking) water <1ppm.	
1ppm = 1mg/L		

### 12: De-Scaling

Limescale on the bore tubes can be caused by a variety of service conditions including high water temperatures or excessively 'hard' water quality.

**! Additives for de-scaling tubes must be checked for suitability with the pipe material, rubber seal ring and approved for use with AusPress before use.**

When using any solution, ensure the system is flushed correctly and the manufacturer's instructions are followed in an accurate and safe manner at all times.

### 13: Commissioning

Systems must be commissioned in accordance with the applicable standards and regulations.

The installation contractor must familiarise the owners and users with the system. This is to be documented with a hand-over and acceptance documentation.

Completing an *Operation and Maintenance Manual* is recommended to record the actual products installed, the ring seals used and the installer's information for future reference.

### 14: Operation and Maintenance

The user (or owner) of the system is under an obligation to ensure the system is maintained in a serviceable and safe condition at all times.

The system must be operated in such a way that faults and other factors affecting the reliability of the system are resolved before a hazard or issue occurs.

Ongoing maintenance includes assessing the interior and exterior of the pipework with regular inspections and timely rectification if required.

Avoid damage by keeping the system clean & free of contaminants, protect from sparks, grindings and confirm changes in media before making changes to operating conditions.

The user is advised to enter into a maintenance agreement with an installation contractor.



# Project Information Form

Please complete this form so we can best advise product suitability and technical assessment for your project.

For the current version of this guide, visit our website.

## Contact Information

(please complete all fields below)

Customer Name:	
Date:	
Client:	
Contractor:	
Main Contact Name:	
Main Contact Phone:	
Main Contact Email:	
Main Contact Address:	

## When Use This Form?

Customers should complete and submit this form for all projects.

Most supply this information at the design stage - the earlier this information is available, the better response we can provide for your design.

## Why?

As part of our product quality assurance, we'd like to ensure what we're supplying will meet the needs of your project.

The more you can tell us, the more certain we can be in supplying you with the right answers.

We have project based water analysis and metallurgy analysis services available for customers too.

## Project Information

(please complete all fields below)

Project Name:			
Project Address:			
Application:			
Diameter:			
Product / Media Name:			
Product Concentration (%):			
	Item:	Temperature	Pressure
Operating Conditions:	Minimum:	°C	kpa / PSI / bar (circle unit)
	Maximum:	°C	kpa / PSI / bar (circle unit)
MSDS: (Material Safety Data Sheets)	<input type="checkbox"/> I've attached the relevant sheets with this form.		
Water Test Results: (Including pH levels)	<input type="checkbox"/> I've attached the reports with this form.		

## More Information?

Any other relevant information...

---



---



---



---



---



---

Email your completed form directly to **technical@auspress.com.au** for assessment.

Please ensure all items are completed for a faster response.



# Test Protocol Form

To pressure test AusPress press-fit, use (potable) water, oil-free compressed air or suitable inert gas as the test medium.

For the current version of this guide, visit our website.

Testing to be in accordance with the recommendations in the Technical Section of the AusPress catalogue.

Project Name:	
Location:	
Customer Name:	
Customer Phone:	
Contractor Name:	
Contractor Phone:	
AusPress System/Material:	
Max Operating Pressure:	kpa / PSI / bar (circle unit)

### Important..

If the system is to be emptied after a water pressure test, or not remain completely full, it is advisable to test with air to avoid an increased risk of pitting and corrosion.

Stagnant water, periods of low water flow (limited or no flushing) and dead legs require caution and are not recommended.

Pre-Test Checks	<input type="checkbox"/> All pipelines are sealed, ready for test.			
	<input type="checkbox"/> Appliances, pressure tanks or hot water heaters are isolated from the piping system.			
	<input type="checkbox"/> A visual check has been carried out to ensure all pipe joints have been executed professionally.			
Pressure Test Parameters		AS/NZS 3500	AS/NZS 5601	AS/NZS 2419.1
	Test Pressure (Whichever is greater of):	1,500 kPa (15 bar, 218psi) or...	7.0 kPa (0.07bar, 1.0psi) (pipework only) or...	1,700 kPa (17 bar, 247psi) or...
		1.5 times the maximum operating working pressure for the completed system.		
	Minimum Test Time Required:	45 minutes	2 minutes temp stabilisation time + 5 minutes for test	4 hours
<b>Note:</b> Refer to the relevant standard in full for specific requirements of testing.				

Test Conditions	Test Medium: <input type="checkbox"/> Potable Water <input type="checkbox"/> Compressed Air* <input type="checkbox"/> Nitrogen		
	Test Temp	Test Pressure	Test Time
	°C	kpa / PSI / bar (circle unit)	mins / hrs (circle unit)
	System tested... <input type="checkbox"/> as an entire system or, <input type="checkbox"/> in sections - qty:		

Test Results	<input type="checkbox"/> There was no pressure drop in test pressure during the test time.
	<input type="checkbox"/> Visual check of all joins resulted in no leaks identified during the test time.
	<input type="checkbox"/> <b>The piping system has been professionally tested and found to be leak proof.</b>
	<input type="checkbox"/> Pressure drop noted = System failed pressure test, rework required before re-testing.
	<b>NCR Number:</b>

_____	_____	_____/_____/_____
Print Name (Contractor)	Print Name (Witness)	Date Signed
_____	_____	
Signature (Contractor)	Signature (Witness)	

Keep this completed document as a record of the process for your records.